



DELIVERING THE GOOD

Strategic Interventions Towards a Just & Sustainable Logistics System in Southern California

TABLE OF CONTENTS

EXECUTIVE SUMMARY	E-1
① INTRODUCTION	1-1
② THE EVOLUTION OF GLOBAL LOGISTICS	2-1
③ THE INLAND PORT	3-1
④ TRANSPORTATION TECHNOLOGY	4-1
⑤ SUPPLY CHAIN MANAGEMENT CASE STUDIES	5-1
⑥ CONCLUSION	6-1
BIBLIOGRAPHY	B-1
GLOSSARY	A-19
ACRONYMS	A-22
BIOGRAPHIES	A-23

DELIVERING THE GOOD: EXECUTIVE SUMMARY

PROJECT DESCRIPTION

The Community Scholars Program is a joint initiative of the UCLA Department of Urban Planning and the UCLA Labor Center. Since 1991, the program has brought labor and community leaders together with UCLA Master of Urban and Regional Planning students to study pressing social issues and develop forward-thinking policy and community-based solutions.

The 2016 Community Scholars project examines the community, labor, and environmental impacts of the goods movement system in Southern California. From the Ports of Los Angeles and Long Beach (the Ports) to the inland warehousing and distribution clusters, this extensive system encompasses some 9,000 lane miles of highways, two Class I railroads, and over one billion square feet of warehousing and distribution centers (Hayes, 2016). Combined, the Ports form the largest container shipping facility in the United States and the eighth largest container port in the world, accounting for approximately 43 percent of the nation's container imports (Bonacich and Wilson, 2008). While the port complex has far-reaching benefits to the Los Angeles regional economy and the national economy, it is also the source of a host of negative impacts that disproportionately affect workers and communities in surrounding areas.

The primary client for this year's project was the Los Angeles Alliance for a New Economy (LAANE). LAANE is a non-profit organization that combines research, policy, and organizing to help build a new economy rooted in good jobs, thriving communities, and a healthy environment. LAANE's Clean and Safe Ports Campaign has been working to bring community, workers, and environmental allies together for a better harbor region. In 2008, LAANE was instrumental in bringing together the Coalition for Clean and Safe

We envision an economy and a goods movement system that transitions away from extractive and exploitative consumption and towards social equity, sustainability, and community power.

COMMUNITY SCHOLARS COHORT, 2016



Ports, an alliance of over 200 organizations, to help pass the Clean Trucks Program, which has resulted in a 90 percent reduction in diesel emissions from trucks that service the Ports. More recently, LAANE has been supporting port truck drivers in their fight for fair working conditions. This Community Scholars project seeks to build upon the existing foundation of research and organizing to contribute to the ongoing and future efforts of the Clean and Safe Ports project.

THE PROBLEM WITH THE GOODS MOVEMENT IN SOUTHERN CALIFORNIA

In simple terms, the Southern California goods movement system degrades the region's air and water, contributes to community health disparities and premature death, and produces economic injustices. Short-haul truckers and warehouse workers in the region are often paid less than minimum wage and experience rampant workplace violations. Residents living along the region's massive network of highways, rail lines, and intermodal freight sites face significantly higher rates of cancer and asthma. These workers and communities are disproportionately composed of low-income people of color, and they have little power to influence the decisions that most impact them. This system also fundamentally depends on the extraction and burning of fossil fuels, the primary cause of global climate change. Thus, the logistics system both drives and relies on the exploitation of human labor. In addition, it also depends on the extraction, depletion, and degradation of natural resources within the region and beyond.

Although the scope of this report is primarily regional, it is important to note that the Southern California logistics system is an integral part of the national and global economic systems. The Port of Los Angeles and the Port of Long Beach compete with each other as well as with other ports in the United States. On a global level, these ports function as a key link between the American consumption economy, which depends on cheap imports, and the countries that produce the cheap goods.



In simple terms, the Southern California goods movement system degrades the region's air and water, contributes to community health disparities and premature death, and produces economic injustices.



Logistics is a critical aspect of this global market. Sociologists Bonacich and Wilson define logistics as "the management of the entire supply chain, encompassing [...] ordering, production, transportation and warehousing [...] and reordering" (2008). Logistics is therefore the literal and figurative infrastructure upon which the global market operates.

This report recognizes that the relative cheapness of labor and production in less developed countries is the result of global hegemony and histories of colonialism, classism, and racism. Thus, logistics, as the backbone of the global economy, is deeply implicated in the perpetuation of these systems of oppression. Logistics is also responsible for contributing to processes of climate change and environmental extraction and degradation.

This project seeks to understand these problems with the underlying belief that the system as it currently exists was created by people, and that it can and must be changed by people. The globalized system of American consumption—and the model of economic growth that depends on logistics—assumes and accepts that some people must bear the costs so that others can experience the benefits. The project team developed the following vision as a framework for creating a just and sustainable goods movement system in Southern California.

PROJECT VISION

The project vision serves multiple purposes. First, it establishes and sets forth the motivations, intentions, and mission of the project by defining what an equitable and sustainable economy could be. Second, it provides a way to assess the goods movement system as it currently exists and operates. Third, it provides structure and organization for the research as presented.

We envision an economy and a goods movement system that transitions away from extractive and exploitative consumption and towards social equity, sustainability, and community power.

This vision draws on the concept of just transition as articulated by the International Labour Organization, the Climate Justice Alliance, and author Naomi Klein (International Labour Organization, 2015; Coronel et al., 2016; Klein, 2014). The concept is premised on the understanding that the dominant financial system is structured to emphasize growth over people's basic human needs, and that it concentrates wealth and power for a relative few at the expense of many. This capitalist economy is fundamentally built upon the extraction of natural resources and the exploitation of labor. The movement believes that "transition is inevitable, but justice is not" (Coronel et al., 2016). A just transition, then, rejects the current model of growth and instead seeks to transform local economies to emphasize ecological sustainability, interdependence, and community self-determination.



**REGIONAL
LOGISTICS
& THE GLOBAL
SUPPLY CHAIN**



**THE INLAND
PORT**



**TRANSPORTATION
TECHNOLOGIES**

Our project vision utilizes three key concepts to frame the just transition of the Southern California goods movement system:

SOCIAL EQUITY, SUSTAINABILITY, AND COMMUNITY POWER.

SOCIAL EQUITY recognizes a deep and complicated history of oppression and disempowerment in the United States and throughout the world. The nature of this oppression is heavily marked by global hegemony, patriarchy, white supremacy and capitalism, all of which has led to unjust concentrations of privileges and resources (Hall, 1980). In order to alleviate past tragedies and injustices, social equity implies access for all to opportunity, livelihood, education, health, and resources; full community participation in public decision-making; self-determination in meeting fundamental needs; and promotion of social justice through public sector and civil society expansion and realignment (“Reliable Prosperity: Social Equity,” n.d.). **Practices that encompass social equity must compensate and empower communities and populations that have been historically exploited. Social equity entails a meaningful redistribution of resources and power towards oppressed peoples.**

SUSTAINABILITY implies that the natural environment, human society, and global economic activity must exist in balance. In this balance, quality of human life, environmental regeneration, and environmental justice should take precedence over profits for individuals and corporations. As climate change forces humans to adapt, sustainability demands a just transition away from fossil fuels, in which affected workers and communities are empowered to envision and create a new energy economy. **Environmental justice goals, human rights, and integrity of natural systems are primary criteria in sustainable economic decision-making.**

COMMUNITY POWER refers to the influence that Southern California communities have over goods movement-related activities and decisions in their neighborhoods. **Community power constitutes a goal of self-advocacy and self-determination for the localities most severely affected by goods movement activities, which are predominantly low-income communities of color.**

These concepts form the framework through which we assess the regional goods movement system and propose strategic interventions to make it more just and sustainable.



SOCIAL EQUITY



SUSTAINABILITY



COMMUNITY POWER

PROJECT SCOPE

This report considers goods movement at three geographic and system scales. It considers the supply chain as a whole, taking a global, whole-system view of logistics in the consumption economy and exploring overarching power relations and institutional dynamics therein.

It then considers the *regional* dynamics and costs of the goods-movement industry, from environmental racism in affected communities to workplace violations in warehouses.

The report then explores specific technologies that the system relies on—including appointment systems at the ports, terminal and truck automation, engine technology, and toll lanes—and their potential to improve outcomes and mitigate negative impacts for local communities and workers.

REGIONAL LOGISTICS & THE GLOBAL SUPPLY CHAIN

The Southern California goods movement system is key to America’s consumption and participation in the global economy. The nation’s transition from a production economy to a consumption economy has meant an exponential growth in import cargo volume, driving growth at the Ports and increased truck traffic and warehousing activity. As of 2016, beneficial cargo owners (BCOs) and regional metropolitan planning organizations have not produced a plan to accommodate such growth and its impacts.

In the current regional logistics system, power is concentrated among BCOs—retailers—while many of the workers and communities most impacted by the system have little influence in decision-making.

In alignment with the vision of this project for a just transition to a socially equitable and sustainable goods movement system in Southern California, this section proposes three strategic interventions to subvert the dominant paradigm and redistribute power to the workers and communities most directly affected by the system.

In the current regional logistics system, power is concentrated among BCOs—retailers—while many of the workers and communities most impacted by the system have little influence in decision-making.

TRANSPORTATION TECHNOLOGIES

APPOINTMENT SYSTEM

In theory, terminal appointment systems spread demand for port terminal space and labor over time, allowing trucks to have easier access to terminals and a swifter movement of goods through the Ports. In 2005, after a decade of dramatic growth at the Ports, the first appointment systems were put in place. However, port congestion persisted in the new system, as it was voluntary and relatively few truckers utilized it, and many terminals extended hours instead of using the appointment system (Giuliano and O'Brien, 2007). During this period, terminal operators and trucking company owners had limited incentives to speed up truck turn times, and truckers themselves lacked the power to influence the system. Over the past few years, some terminals have shown an increased—and encouraging—willingness to collaborate with all other terminals at the Ports to fight congestion. That being said, turn times are still unacceptably high (Mongelluzzo, 2015), and truckers suffer because they are usually paid by the load rather than by the hour.

CONTAINER TERMINAL AUTOMATION

Terminal automation within the worldwide logistics system is still relatively rare. The Ports only boast two partially automated terminals, the TraPac Terminal and the Middle Harbor Terminal (City of Los Angeles Harbor Department Planning and Economic Development Division, 2014). There are clearly some advantages to terminal automation; the process is more efficient and safer for workers, and it can reduce air pollution levels. However, there are concerns about job losses; furthermore, even if some jobs were retained through the retraining of ILWU dockworkers and other port workers, it is uncertain that their level of pay could be maintained.

TRANSPORTATION TECHNOLOGIES DISCUSSED WITHIN REPORT



1. Appointment System
2. Container Terminal Automation
3. Reducing Emissions from Port Trucking
4. Truck-Only Toll Lanes
5. Trucking Automation

REDUCING EMISSIONS FROM PORT TRUCKING

While the air quality surrounding the Ports is far cleaner than in recent decades, the residential areas surrounding the Ports still suffer from high rates of asthma, emphysema, and other ailments caused by particulates in the air. The Clean Trucks Program successfully improved air quality by banning old, polluting diesel trucks, but it negatively impacted many port truckers who were forced to pay for the new, upgraded trucks due to their status as misclassified independent owner operators (IOOs). While it is essential to mandate near-zero and zero-emissions trucks in order to reduce health impacts and meet federal air quality attainment standards, it is also important that the cost burden not fall on IOOs. There is debate surrounding which fuels and technologies are the best solutions, with significant political and financial support leaning towards electric trucks. Research shows that there are more feasible alternatives available, including the use of renewable natural gas with natural gas engines.

TRANSPORTATION TECHNOLOGIES, continued

TRUCK-ONLY TOLL LANES

Local transportation agencies have been studying the implementation of truck-only toll lanes for many years, as they would allow for more reliability and quicker travel speeds northward and eastward from the Ports. Truck-only toll lanes would also reduce collisions and possibly encourage the use of cleaner truck vehicles (if, for example, the use of the toll lanes were conditioned upon newer vehicles). While the benefits of such lanes are highly touted for truck drivers and for the competitiveness of the regional economy, local communities have often been left out—explicitly or implicitly—from the planning process. This is especially problematic considering that toll-lanes are often built as new lanes; they are dependent upon freeway widening; and they are almost certain to generate new trucking trips through communities that are already suffering from heavily polluted, poor quality air.

TRUCKING AUTOMATION

Trucking automation is actively being implemented. Due to the inherent complexities of short-haul navigation through major urban areas, automated trucks will penetrate the long-haul market first. Advances in automation may address efficiency and environmental concerns; however, the impacts of automation on job access and job quality for truck drivers will depend on policy interventions that encourage worker protections and retraining. The process of fully replacing long-haul and short-haul drivers with computers will likely take decades. In the meantime, the IOO model must end as soon as possible if the system is to become more efficient—and humane and equitable—in the meantime.

TRANSPORTATION TECHNOLOGY GROUP DISCUSSES POWER DYNAMICS WITHIN THE GOODS MOVEMENT



Source: Goetz Wolff, UCLA Downtown Labor Center

It is worth noting that all of the interventions in this chapter of the report are limited in their efficacy if the IOO system remains. In this system, drivers are currently paying for congestion while terminal operators and trucking company owners are indifferent to it. Therefore, efforts to move away from the IOO model should be encouraged as much as possible.

SUMMARY OF STRATEGIC INTERVENTIONS

The following interventions are a summary of the strategic interventions for a equitable, sustainable goods movement system based on community power. The interventions are organized according to the three research topics (1) regional logistics and global supply chain, (2) the inland port, and (3) transportation technology.

REGIONAL LOGISTICS & THE GLOBAL SUPPLY CHAIN

Federal Port Policies

Federal Port Policies should set standards for equitable work, environmental sustainability, and community involvement in decision-making at all US ports.

Fair Transport Campaign

Advocates should utilize a **Fair Transport Campaign** to raise consumer consciousness about the negative impacts of the logistics system.

Cross-Sector Alliances

Workers and communities should organize together and build **cross-sector alliances** in the region as part of an international movement towards a just transition.

THE INLAND PORT



Align Existing Regulatory Tools

Municipalities should **align existing regulatory tools**, including CBAs, Green Zones, and CalOsha policies, for local implementation in an Environmental Justice Element to minimize harms of warehousing and infrastructure development, and improve jobs.

Goods Movement Oversight Board

The California state legislature should create a **Goods Movement Oversight Board (GoMOB)** similar to the existing Coastal Commission that would assume regional project permitting and planning authority over goods movement development and infrastructure. Board members would be majority community residents and workers to ensure that environmental justice and worker rights at the forefront of decisions.

INTERVENTIONS KEY

-  Social Equity
-  Sustainability
-  Community Power

THE INLAND PORT CONTINUED

Taxes on Industry-Users of Transit Infrastructure

Federal, state and local governments should implement additional **taxes on industry-users of public transportation infrastructure** to offset negative externalities, and allow communities decide how to implement spending plans and mitigations.

Congress should increase current **excise taxes on diesel and tires** to offset current external costs of moving goods incentivize fuel-efficient trucks, and disincentivize heavy loads that damage roads.

Ports should impose a **variable charge on containers** based on weight and distance to be reinvested in road maintenance costs and community health.

Transportation agencies should charge **user-based fees for freight-only corridors** to finance construction and benefits for impacted communities.

Realign Public Investments

Federal, state, regional, and local transportation agencies should **realign public investments** to offer reparations for past harms related to infrastructure and to subsidize transit and sustainable economic development goals.

Reparative public investments should be decided by communities and potentially include local environmental mitigation, local economic development, and local sourcing.



Alternative transportation investments should increase allocations for transit and prioritize creation of a rotating zero-interest loan fund incubator for worker owned co-ops producing transportation-related goods and services.

TRANSPORTATION TECHNOLOGY

Terminal Operator Fines

The Ports should **fine terminal operators** for long total turn-times and give this money back to waiting truckers and the local residential community which suffers from poor air quality caused by excessive idling. The community should define how the funding should be used within certain parameters. The data needed to implement this program will come from GPS sensors that the Ports could mandate for all trucks serving the Ports.

INTERVENTIONS KEY

-  Social Equity
-  Sustainability
-  Community Power

TRANSPORTATION TECHNOLOGY CONTINUED

Flexible PierPass Program

The Ports should encourage a more **flexible PierPass program** in which the GPS sensors on trucks allows for the collection of “big data” on truck movements. This would allow for more demand-based and flexible pricing schemes, which would improve efficiency at the Ports.

Free-Flow Container System

The Ports should continue to encourage **free-flow container systems**. Such systems boost productivity dramatically, but their utilization can necessitate the creation of large container yards for transloading in nearby communities. Thus, the Ports should mandate a per TEU fee on each container and reinvest some of that money back into the community on environmental projects that can mitigate the increased truck trips in the area.

Green Job Training for Displaced Workers & Impacted Communities

Prioritize **green jobs for displaced workers and impacted communities**. The SEED Program, a HUD-affiliated program to increase STEM engagement among low-resourced communities, should also be expanded.

Career Pathways in Sustainable Industries

Leverage public workforce development funds with public-private partnerships to create more **career pathways in sustainable industries**.

Community Benefits Agreements

Regional transportation agencies, including SCAG and Metro, and/or state agencies, including Caltrans, should negotiate **Community Benefits Agreements** as part of regional truck-tollways like the proposed Clean Freight Corridor.



Community & Trucker Inclusion within JPA

Ensure the **inclusion of community groups and truck driver representatives on the Joint Powers Authority (JPA)** that implements the regional network of truck tollways, especially considering the anticipated public subsidy involved with the project.

Clean Trucks 2.0

Clean Trucks 2.0: Implement incentives and mandates to **replace the current fleet of heavy duty diesel trucks with .02 natural gas** engines fueled by renewable natural gas. Ensure that the financial burden does not fall on misclassified truck drivers.

INTERVENTIONS KEY

-  Social Equity
-  Sustainability
-  Community Power



1

INTRODUCTION

SAM APPEL, EVAN MOORMAN, & STEPHANIE TSAI

CHAPTER 1: INTRODUCTION

PROJECT DESCRIPTION

The Community Scholars Program is a joint initiative of the UCLA Department of Urban Planning and the UCLA Labor Center. Since 1991, the program has brought labor and community leaders together with UCLA Master of Urban and Regional Planning students to study pressing social issues and develop forward-thinking policy and community-based solutions.

The 2016 Community Scholars project examines the community, labor, and environmental impacts of the goods movement system in Southern California. From the Ports of Los Angeles and Long Beach (the Ports) to the inland warehousing and distribution clusters, this extensive system encompasses some 9,000 lane miles of highways, two Class I railroads, and over one billion square feet of warehousing and distribution centers (Hayes, 2016). Combined, the Ports form the largest container shipping facility in the United States and the eighth largest container port in the world, accounting for approximately 43 percent of the nation's container imports (Bonacich and Wilson, 2008). While the port complex has far-reaching benefits to the Los Angeles regional economy and the national economy, it is also the source of a host of negative impacts that disproportionately affect workers and communities in surrounding areas.

The primary client for this year's project was the Los Angeles Alliance for a New Economy (LAANE). LAANE is a non-profit organization that combines research, policy, and organizing to help build a new economy rooted in good jobs, thriving communities, and a healthy environment. LAANE's Clean and Safe Ports Campaign has been working to bring community, workers, and environmental allies together for a better harbor region. In 2008, LAANE was instrumental in bringing together the Coalition for Clean and Safe

We envision an economy and a goods movement system that transitions away from extractive and exploitative consumption and towards social equity, sustainability, and community power.

COMMUNITY SCHOLARS COHORT, 2016



Ports, an alliance of over 200 organizations, to help pass the Clean Trucks Program, which has resulted in a 90 percent reduction in diesel emissions from trucks that service the Ports. More recently, LAANE has been supporting port truck drivers in their fight for fair working conditions. This Community Scholars project seeks to build upon the existing foundation of research and organizing to contribute to the ongoing and future efforts of the Clean and Safe Ports project.

THE PROBLEM WITH THE GOODS MOVEMENT IN SOUTHERN CALIFORNIA

In simple terms, the Southern California goods movement system degrades the region's air and water, contributes to community health disparities and premature death, and produces economic injustices. Short-haul truckers and warehouse workers in the region are often paid less than minimum wage and experience rampant workplace violations. Residents living along the region's massive network of highways, rail lines, and intermodal freight sites face significantly higher rates of cancer and asthma. These workers and communities are disproportionately composed of low-income people of color, and they have little power to influence the decisions that most impact them. This system also fundamentally depends on the extraction and burning of fossil fuels, the primary cause of global climate change. Thus, the logistics system both drives and relies on the exploitation of human labor. In addition, it also depends on the extraction, depletion, and degradation of natural resources within the region and beyond.

Although the scope of this report is primarily regional, it is important to note that the Southern California logistics system is an integral part of the national and global economic systems. The Port of Los Angeles and the Port of Long Beach compete with each other as well as with other ports in the United States. On a global level, these ports function as a key link between the American consumption economy, which depends on cheap imports, and the countries that produce the cheap goods.



In simple terms, the Southern California goods movement system degrades the region's air and water, contributes to community health disparities and premature death, and produces economic injustices.



Logistics is a critical aspect of this global market. Sociologists Bonacich and Wilson define logistics as “the management of the entire supply chain, encompassing [...] ordering, production, transportation and warehousing [...] and reordering” (2008). Logistics is therefore the literal and figurative infrastructure upon which the global market operates.

This report recognizes that the relative cheapness of labor and production in less developed countries is the result of global hegemony and histories of colonialism, classism, and racism. Thus, logistics, as the backbone of the global economy, is deeply implicated in the perpetuation of these systems of oppression. Logistics is also responsible for contributing to processes of climate change and environmental extraction and degradation.

This project seeks to understand these problems with the underlying belief that the system as it currently exists was created by people, and that it can and must be changed by people. The globalized system of American consumption—and the model of economic growth that depends on logistics—assumes and accepts that some people must bear the costs so that others can experience the benefits. The project team developed the following vision as a framework for creating a just and sustainable goods movement system in Southern California.

PROJECT VISION

The project vision serves multiple purposes. First, it establishes and sets forth the motivations, intentions, and mission of the project by defining what an equitable and sustainable economy could be. Second, it provides a way to assess the goods movement system as it currently exists and operates. Third, it provides structure and organization for the research as presented.

We envision an economy and a goods movement system that transitions away from extractive and exploitative consumption and towards social equity, sustainability, and community power.

This vision draws on the concept of just transition as articulated by the International Labour Organization, the Climate Justice Alliance, and author Naomi Klein (International Labour Organization, 2015; Coronel et al., 2016; Klein, 2014). The concept is premised on the understanding that the dominant financial system is structured to emphasize growth over people's basic human needs, and that it concentrates wealth and power for a relative few at the expense of many. This capitalist economy is fundamentally built upon the extraction of natural resources and the exploitation of labor. The movement believes that "transition is inevitable, but justice is not" (Coronel et al., 2016). A just transition, then, rejects the current model of growth and instead seeks to transform local economies to emphasize ecological sustainability, interdependence, and community self-determination.



**REGIONAL
LOGISTICS
& THE GLOBAL
SUPPLY CHAIN**



**THE INLAND
PORT**



**TRANSPORTATION
TECHNOLOGIES**

Our project vision utilizes three key concepts to frame the just transition of the Southern California goods movement system:

SOCIAL EQUITY, SUSTAINABILITY, AND COMMUNITY POWER.

SOCIAL EQUITY recognizes a deep and complicated history of oppression and disempowerment in the United States and throughout the world. The nature of this oppression is heavily marked by global hegemony, patriarchy, white supremacy and capitalism, all of which has led to unjust concentrations of privileges and resources (Hall, 1980). In order to alleviate past tragedies and injustices, social equity implies access for all to opportunity, livelihood, education, health, and resources; full community participation in public decision-making; self-determination in meeting fundamental needs; and promotion of social justice through public sector and civil society expansion and realignment (“Reliable Prosperity: Social Equity,” n.d.). **Practices that encompass social equity must compensate and empower communities and populations that have been historically exploited. Social equity entails a meaningful redistribution of resources and power towards oppressed peoples.**

SUSTAINABILITY implies that the natural environment, human society, and global economic activity must exist in balance. In this balance, quality of human life, environmental regeneration, and environmental justice should take precedence over profits for individuals and corporations. As climate change forces humans to adapt, sustainability demands a just transition away from fossil fuels, in which affected workers and communities are empowered to envision and create a new energy economy. **Environmental justice goals, human rights, and integrity of natural systems are primary criteria in sustainable economic decision-making.**

COMMUNITY POWER refers to the influence that Southern California communities have over goods movement-related activities and decisions in their neighborhoods. **Community power constitutes a goal of self-advocacy and self-determination for the localities most severely affected by goods movement activities, which are predominantly low-income communities of color.**

These concepts form the framework through which we assess the regional goods movement system and propose strategic interventions to make it more just and sustainable.



SOCIAL EQUITY



SUSTAINABILITY



COMMUNITY POWER

PROJECT SCOPE

This report considers goods movement at three geographic and system scales. It considers the supply chain as a whole, taking a global, whole-system view of logistics in the consumption economy and exploring overarching power relations and institutional dynamics therein.

It then considers the regional dynamics and costs of the goods-movement industry, from environmental racism in affected communities to workplace violations in warehouses.

The report then explores specific technologies that the system relies on, including appointment systems at the ports, terminal and truck automation, engine technology, and toll lanes, and their impact on local communities and workers.

METHODOLOGY

The Community Scholars project team consisted of students in the UCLA Master of Urban and Regional Planning (MURP) program and participants from LAANE, Communities for a Better Environment, East Yard Communities for Environmental Justice, Teamsters Port Division, and Our Walmart.

The project spanned two academic quarters in 2016. Over this period, the students conducted literature reviews, dozens of interviews, site visits and tours, and spatial analysis and mapping. This research covered a wide range of perspectives from a variety of stakeholders, including governmental bodies, community organizations, labor unions, researchers, advocates, and private industry representatives. The team toured the port complex and surrounding communities as well as a major distribution center in Riverside County. Some of the project team attended regional and national conferences on the logistics industries, environmental sustainability, and transportation research.

The students were initially organized into three groups to explore these broad areas:

1. **Regional employment and economic development:** considering the quantity and quality of jobs in the sectors of the ports, trucking, and distribution centers, as well as worker representation and community economic impacts.
2. **The goods movement transportation system:** shipping, terminal operations, trucking, rail, and the resulting impacts on productivity, congestion, and transportation safety.
3. **Health impacts:** focusing on issues of environmental justice, both for communities and workplaces, considering air quality, community safety, and living and working conditions.

After reviewing literature and further developing the scope of the project, the students reorganized into different topic groups to delve into more depth and specificity while utilizing these three areas as contextual perspectives through which to research and analyze aspects of the goods movement system. Participants then engaged in a collective visioning process and established the above framework for assessing the existing goods movement system and developing strategic ways to make the system more just and sustainable.

REPORT ORGANIZATION

The rest of this report is structured in five main parts:

CHAPTER 2 provides an overview of the Southern California goods movement system and a brief historical context for the development of supply chain logistics. Included in this section is an explanation of how neoliberal federal and international trade policies and the shift from a production economy to a consumption economy have shaped the logistics system. This provides context for understanding power dynamics in the goods movement system and the switch from a push model to a pull model, acknowledging that the scope of the project is local and regional rather than global.

CHAPTER 3 focuses on the inland clustering of warehousing, distribution, and other port functions. It examines how the spatial distribution of these processes impacts labor, communities, transportation infrastructure, public health, and the environment.

CHAPTER 4 focuses on the current and future impacts of the port-related transportation system and emerging technologies, from universal appointment systems to port infrastructure to renewable energy. It considers implications for congestion, pollution, labor, and public participation.

CHAPTER 5 provides case studies of three major beneficial cargo owners (BCOs). It briefly explains how their business models and supply chains affect goods movement in Southern California and how they are in turn affected by changes in the system.

CHAPTER 6 the report concludes by summarizing and reviewing the vision for a just and sustainable goods movement system and strategic interventions that can be implemented to move closer to that vision.

COMMUNITY SCHOLARS COHORT, 2016



Source: Goetz Wolff, Port of Los Angeles



2

THE EVOLUTION OF GLOBAL LOGISTICS

MEGHMIK BABAKHANIAN, SALY HENG, LINDSEY JAGOE, EDBER MACEDO, & STEPHANIE TSAI

CHAPTER 2: THE EVOLUTION OF GLOBAL LOGISTICS

GLOBALIZATION TAKES SHAPE

Since the end of World War II, realigning industries and evolving trade relations have dramatically changed how foreign economies interact with one another. Many countries have exponentially increased their volume of international trade and their participation in global capital markets. These developments have transformed how society produces, consumes, and trades goods around the world. Prior to World War I, international trade was largely structured by colonial relations and limited by pre-container technology. This applied to both raw materials and finished products. Between World War I and World War II, many industrialized nations limited their international trade through protectionist policies such as tariffs and quotas. In the time immediately after World War II, the United States largely produced and consumed its own goods domestically (Nanto, 2010).

However, beginning in the 1970s, many countries, including those with strong economies as well as developing countries, adopted international trade models that transformed both global and domestic markets. At that point in time, many developing countries entering the international marketplace did not have advanced industrial economies in place to be able to reap as many benefits as their western and European counterparts. Developing countries, in an effort to attract investment, exercised limited government oversight, particularly with respect to labor and environmental regulations (Bonacich and Wilson, 2004). Strong industrialized powers such as the United States were able to take advantage of favorable trade terms and a lack of regulation in developing nations. This further drove the increase in neoliberal trade policies, such as deregulation (Bonacich and Wilson, 2004). International organizations, such as the International Monetary Fund who provide financial assistance to nations, bolstered the growth of the global economy and accelerated a trend of increasing imports and decreasing production in the United States.

IN THIS SECTION



GLOBALIZATION TAKES SHAPE 2-2

EXPORTING EMPLOYMENT
OPPORTUNITIES ABROAD 2-3

A NEW AMERICAN ECONOMY 2-4

EFFECTS ON THE AMERICAN
WORKFORCE 2-5

CLIMATE CHANGE'S
CHALLENGE TO THE
ECONOMY 2-7

CHALLENGES IN THE GLOBAL
& REGIONAL SUPPLY CHAIN 2-8

HISTORY OF SUPPLY CHAIN
LOGISTICS IN SOUTHERN
CALIFORNIA 2-10

The emerging neoliberal ideology prompted regional trade agreements across hemispheres, which contributed to the strengthening of global trade. Central America and Southeast Asia became the center of attention for companies looking to begin new manufacturing operations and information sectors (i.e. telecommunication). In a notable example, the US, Canada, and Mexico signed a free trade agreement that made it simpler to conduct international business and lifted restrictions for corporations and capital to move between these countries, but not people. The North American Free Trade Agreement went into effect on January 1, 1994 and became a well-documented example of how free trade agreements can widen income inequality in Third World nations and can have no real benefit to developed countries (Polaski, 2006). The United States went on to enter additional free trade agreements with nations in Central America, East Asia, and South America (Office of the United States Trade Representative, 2016). These trade agreements, compounded by deregulated industries, have made decreasing costs and increasing employer profit an easy task, especially in countries that are still developing. Those economic models have translated into some industries declining in workforce numbers and some workforce operations moving to different countries - all due to a variety of factors. Some leading causes were because of off shoring, automated machinery, and much more. As a result, operations along the supply chain that require high skilled workers, including engineering, design, research and development, and marketing, tend to be located in higher wage countries, such as the US, Germany, and Japan (Nanto, 2010). In contrast, some company operations requiring lower skilled workers, including assembly and packaging, were relocated to countries such as China and India (Nanto, 2010).

EXPORTING EMPLOYMENT OPPORTUNITIES ABROAD

As it has become easier for corporations to operate globally, it has also become more difficult for governments to oversee worker protections and other business operations. As the volume of exchanged goods and services between nations continues to grow, the supply chain management sector continues to reinvent itself to maximize efficiencies at the lowest available cost at each point within the supply chain. Companies have realized that passing on costs to a different level of the supply chain can be a strategy towards ensuring profit. This trend has been fueled through the rise of various business management strategies including a focus on “core competencies,” which is the idea that firms should focus their effort on comparative advantages allowing all other activities to be outsourced (Nanto, 2010). Those types of economic trends provided the justification to outsource manufacturing to other countries around the world.

BY THE NUMBERS



#1
Southern California has the largest container port complex in the US

837 Million
square feet of warehouse space in the SCAG region

\$2.6 Billion
cost of wasted labor hours & fuel from truck congestion on highways

47%
of NOx emissions in South Coast Air Basin came from goods movement sources in 2008

Source: SCAG Freight Fact Sheet, 2015

As globalization has intensified, so has economic inequality between Western nations and countries still growing (Wade, 2004; Maskin, 2014). The emergence of the global supply chain has resulted in two economic trends: the dispersion of supply chain roles across various companies and less permanent work. Within the world of global supply chains, corporate and social interests are often in conflict with one another. For example, a US owned business, with the goal of minimizing production costs, may move assembly operations abroad, which would be in direct contrast to the goal of retaining broad employment opportunities in the US, including low skilled work. The policy recommendations and interventions in Chapter VI address the growing economic inequality within the logistics industry by shifting power to communities and workers most negatively affected by the system.

A NEW AMERICAN ECONOMY

Various factors, such as trade and shifts in technology, contributed to the shift from a production economy to a distribution economy (KPMG, 2015). Prior to the 1980s, the United States had a large manufacturing sector, roughly 20 million workers. A variety of goods, such as automobiles, apparel, furniture, and household appliances, were produced domestically as opposed to in foreign countries (Federal Reserve Bank of St. Louis, 2016). Towards the latter quarter of the 20th century, a large segment of manufacturing jobs were replaced with automated machinery that decreased labor costs and saved businesses a significant amount of capital. Large-scale employers (i.e. Walmart, Target, Sears) favored this new approach. Additional technological advances enabled other large corporations to expand in the service industry (i.e. fast-food and retail outlets) (Tilly, 2014). As less people produced fewer goods in factories, with the loss of manufacturing jobs and the import of manufacturing products, jobs grew in the retail industry.

The change in the traditional economic production model in the US illustrated how businesses were responding to “push factors” in the global logistics realm. Through the 1970s, consumers were given more options as to how they purchased and consumed products; suppliers began pushing goods to the United States and then having the retailer create demand in retail outlets (Ryan, Trumbull, and Tufano, 2010). Since many products, such as clothes and household appliances, were being assembled and manufactured in foreign countries, the prices dropped significantly for consumers. Consumer spending increased as a result of how affordable items were and the cheap manner they could be produced in other countries. As a result, the tradeoffs with these “push” factors in global logistics is that people had access to cheaper goods, but workers were getting paid less (Schapiro,

The emergence of the global supply chain has resulted in two economic trends: the dispersion of supply chain roles across various companies and less permanent work.

Within the world of global supply chains, corporate and social interests are often in conflict with one another.

2009). In recent times, with the rise of online shopping, the way people buy their items is a direct result of international trade and domestic economic agendas that enable low prices and low wages. That is, suppliers (or corporations) have used free trade agreements, technology, and a society's willingness to consume more to their advantage (Womack, 2006). Such a sudden emergence of imports and trade means more cargo at American seaports and trucks delivering those items on local roads. Although the consumer does have a stake (or a "say" as some corporations describe), it is ultimately employers who have expanded the pool of exploited labor.

Parallel to a changing American economy and deregulation in the 1980s, retailers began changing the way they ordered products and services to their establishment. Historically, retail businesses and corporations would order a designated amount of products and then stored them in a warehouse. A recent trend, as a result of global trade, point of sale technology, and an accelerated goods movement, adopted by many businesses is where volume is conveniently an order away from one's office (Cachone and Fisher, 2000). Consumer trends and retail phases have prompted businesses to respond to those demands. Consumers, in sum, are influencing the order of how and when BCOs contact their suppliers for more products (Krumwiede, Lummus, and Vokurka, 2001). The rise in temporary workers, independent distribution centers, and logistics operators - all separate from a BCO (i.e. Target) - allows companies to drop an inventory model. Instead, tasking outside agencies to ship and store a company's inventory permits several things: a) reduced costs, b) externalizing responsibility of that cargo, and c) a straightforward manner of ordering items. The "pull" model is also colloquially known as the "just-in-time" approach. Chapter III elaborates more on the profound implications of expanding temporary work sectors, particularly in the warehouse industry. When considering the negative externalities of new business models in this emerging supply chain, the effect on American workers merits careful attention.

EFFECTS ON THE AMERICAN WORKFORCE

In the 1980s, notable management trends in the service industry cleared a pathway for cheaper labor, less expensive items, and a higher social cost for American workers. A myriad of factors including underpaid workers, and exploitative workplace environments in other countries ensures beneficial cost-savings for businesses (Mayer and Pickles, 2010). During the 1980s, federal and state policy makers reformed labor and industry standards that awarded employers more freedom and decreased oversight (Western and Rosenfield, 2011). Within those new circumstances, large companies do not see the need for a full time skilled worker. Workers, at all stages of the supply chain, not just in

In the 1980s, notable management trends in the service industry cleared a pathway for cheaper labor, less expensive items, and a higher social cost for American workers.

A myriad of factors including underpaid workers, and exploitative workplace environments in other countries ensures beneficial cost-savings for businesses.

the establishment store, face longer hours for lower wages than in the past (U.S. Census Bureau, 2015). Management strategically implemented plans to lower prices by cutting quality jobs and increased profitability (Buera and Kaboski, 2009). Wealthy retailers and corporations successfully utilized global trade to their advantage so they could also cut costs in the U.S. economy. Businesses were successful in decreasing costs, but also, indirectly, reduced worker protections working class. Several trade-offs in this new economy include new challenges in unionizing a workplace to due to flexible standards, lower wages in the workplace, and less coverage of worker protections in different industries. In order to grasp the root of where all the negative externalities arise from, the global supply chain, from the very first stage, is important to mention in this context.

Today, large ships and the proliferation of trade agreements set up a new path for the goods movement; that is, they can deliver more items with less resources and ships. One key element in understanding the problem with this model begins with how goods arrive to the West Coast of the United States: via the shipping lines across the Pacific. This industry is imperative to free flowing goods movement, but is also riddled with poor logistical planning practices (Vernimmen, Dullaert, and Engelen, 2007). Different shipping lines will form chartered organizations through vessel sharing agreements (VSA) that make it easier for them to move commerce throughout the world. VSAs help these logistics companies move cargo faster by utilizing ships and sharing cargo space with other shipping lines. Similar to the petroleum drilling sector, these “alliances” also have an effect on prices and competition. While those approaches are financially sound from a management perspective, emerging research illustrates a contrasting narrative of negative external factors of the other supply chain stages (Sarkis and Zhu, 2007; Carter and Jennings, 2002).

Numerous goods movement experts and labor relations analysts have remarked on how the shipping lines mold society's ability for consumption and the effect it has on other segments of the supply chain. The underlying issue is the high volume of cargo arriving at the POLB and POLA. Union organizer Bobby Olvera remarks on how the consolidation of shipping lines into VSAs and the growing pressure to send more cargo than ever exacerbate problems at the port and throughout the distribution phase (Olvera, 2016). His experience as both an organizer and a longshoreman represents an overlooked segment of goods movement research outside the trade journals and management literature. Furthermore, these shipping lines, through the VSAs, bring tons of cargo in a financially and environmentally unsustainable manner. The cargoes onboard these ships are not organized and therefore become quite the predicament for longshore workers to organize once on shore. The longer it takes to unload cargo off the ship and sort through the items, the longer the queue of diesel-fuel emitting trucks clog the region's roads (Olvera, 2016). Further research on

COMMUNITY SCHOLARS LABOR PANEL

ILWU's Mark Jurisic, IBT Organizer Carlos Santamaria, LAANE's Sherheryar Kaoosji, and WWRC's Celine Perez discuss labor conditions along the supply chain in Southern California



Source: Goetz Wolff

COMMUNITY SCHOLARS CLASS PANEL

ILWU 13 President Bobby Olvera and Moving Forward Network's Policy Director Angelo Logan discuss labor and environmental implications of the goods movement

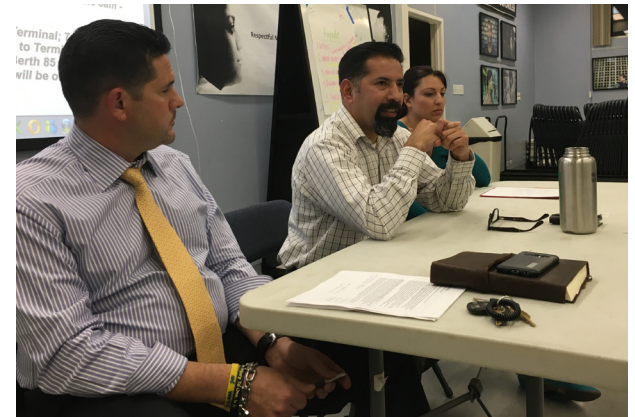

Source: Goetz Wolff

what explicit obstacles shipping lines face and what problems they exacerbate can provide greater insight for policymakers. Ultimately, further research should include both the technical expertise of logistics researchers, longshore workers, and environmental experts to prescribe more accurate plans to change the goods movement system for the better.

CLIMATE CHANGE'S CHALLENGE TO THE ECONOMY

The growth of global supply chains and international trade also entail negative repercussions on environmental quality, especially given the urgency of climate change. The production, distribution, and consumption of goods has severe detrimental effects at varying scales. On a global scale, different companies take advantage of lax environmental regulations that result in polluting natural areas, increasing air pollution, and degrading the quality of life in countries that are developing (Pure Earth, 2002). The lack of delicate attention by large BCOs, in many phases of the supply chain, towards sustainability exacerbates climate change problems.

In the United States, due to stricter environmental regulations, BCOs do have to abide to a higher standard in comparison to countries that are growing. In Los Angeles County for example, frequency of more ships delivering to our seaports, increases the pollution burden on local communities. Large cargo ships utilize environmentally harmful fuels and disturb local marine ecosystems without any punitive action towards polluters (POLB & POLA, 2012). Moreover, as new technology emerges and a fragmented labor force in some logistics industries increases, warehouses enable long diesel-fueled commutes near residential neighborhoods (many of them being low-income and communities of color). Given outstanding expectations of how much more people will consume and how much people will produce, policymakers need to intervene on behalf of people's environments as the Ports expand infrastructure and cities mitigate negative externalities.

The production, distribution, and consumption of goods has severe detrimental effects at varying scales.

On a global scale, different companies take advantage of lax environmental regulations that result in polluting natural areas, increasing air pollution, and degrading the quality of life in countries that are developing.

CHALLENGES IN THE GLOBAL & REGIONAL SUPPLY CHAIN

In supply chain and logistics, there will always be least one part in the system that is less efficient and thus leaving every other process to be affected by its delay. For example, retailers wait for manufacturers, who wait for suppliers, who wait for raw materials distributors. Any delay in the chain can easily multiply and lead to larger inefficiencies later on, especially when there are schedules and timelines to follow. This sensitivity in the system is what must be considered when working towards more equitable practices.

While there have been movements to upgrade management practices, stop trade agreements, and limit environmental impacts, each have been fairly isolated, which tend to have unforeseen ripple effects across the supply chain. For example, the ILWU's ability to cause the West Coast slowdown in 2014-2015 led to overstocking for retailers. High inventory levels resulted in a decrease of future orders later that year, which ultimately decreased business for shipping companies (Solomon, 2016). The ILWU's demonstration was beneficial in that it led to an eventual labor agreement with the PMA, however, it also left independent truck owners/operators, who are paid per load, as well as temporary workers in warehouses, who are scheduled based on demand for their labor, with less work and less pay. Another instance of supply chain disruption is the 2008 implementation of the Clean Truck Program. Here, environmental and community groups were successful in dramatically reducing overall pollution and emissions from heavy trucks, but the program resulted in increased financial burdens to independent owner/operators that were forced to purchase new trucks (Cummings, 2015). Provisions were initially included to regulate truck driver employment, but they were not included in the final approved version of the program.

In addition to impacts from minute changes in the supply chain, some predictions of change can vastly affect every area of the system. The forecasting of goods movement and projection of increased cargo

FIGURE 2.1: SCAG 2013 TRUCK FORECAST COMPARING 2008 AND 2035 TRUCK TRAFFIC

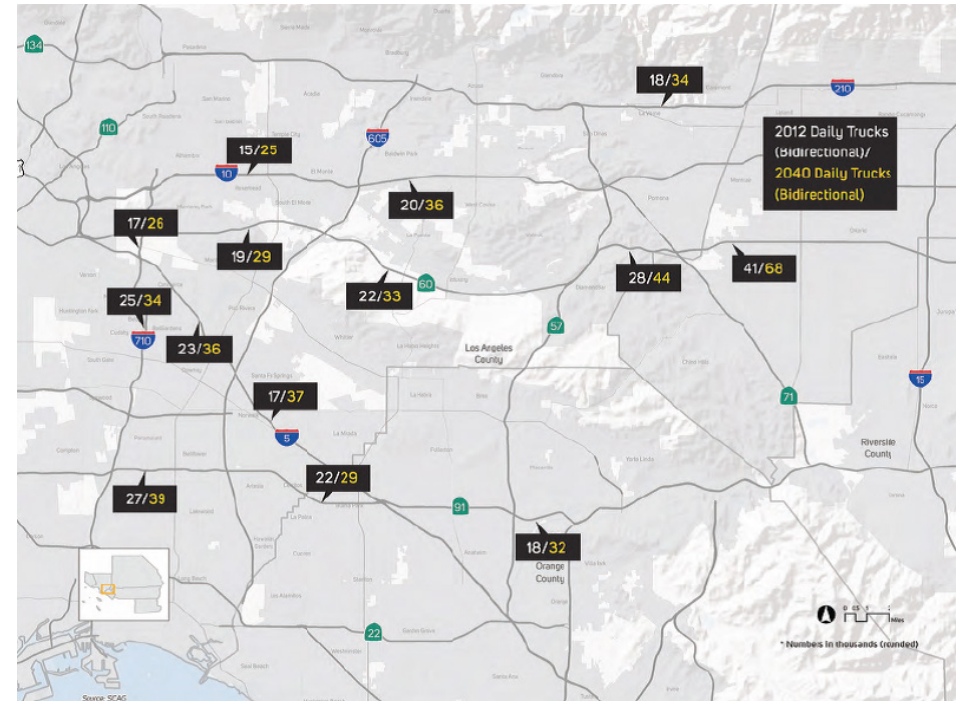

Source: SCAG 2012 & 2016 RTP/SCS

does exactly that. SCAG presented a forecast of containerized imports doubling by 2030. By 2035, the demand will have almost tripled since year 2010 (SCAG, 2013). As a result, all links in the supply chain have been scrambling to increase their capacity, which ultimately gave leverage for private industry to receive public funding that is dedicated to freight and goods movement (FHWA, 2016). An issue arises when considering the potential for this projected growth to be inaccurate. **Figures 2.1** and **2.2** show regional truck traffic in 2008 and 2012.

When comparing the two maps, there are dramatic differences in the future forecast. The existing truck traffic in 2008 and 2012 have increased a fairly gradual, one-thousand trucks in a 4-year span, while in other areas there are dramatic increases in traffic, as well as dramatic decreases. Some examples of this are on I-710 and SR-60, two major freight trucks corridors in the region. For I-710, SCAG report about 24 thousand trucks using the facility delay in 2008. In 2012, they reported 25 thousand trucks. That indicates a one thousand truck increase in 4 years. However, the forecasted volumes are very different from each other. In 2012, SCAG forecasted 53 thousand trucks by 2035, while in 2016, they predicted only 34 thousand in 2040. This reduction in forecasted trips also happens for the SR-60 segment between I-605 and SR-57. The SCAG forecast in 2012 for 2035 is much higher than the newly released 2016 forecast for 2040. This variability in data and the counts, as well as the forecasting methods raises a concern that the current truck trip projections may still be higher than what it should actually be. Given these circumstances and the snowballed decision making from such predictions can lead to unnecessary investments in the supply chain.

CONCLUSION

In closing, e-commerce, suppliers intent on lowering prices, and the expansion of unstable and unprotected workers converts these “push” factors into something that could potentially harm our economy in the long term. The 10 year-old child suffering from asthma near a truck route or the temporary employee in a 110-degree warehouse are both part of larger economic movement. Their outcomes and circumstances are shaped by global trade agreements and a foreign country's acceptance of new manufacturing operations. Moreover, the growing reliance on temporary workers and logistics managers (also known as 3PLs and 4PLs) has both benefited BCOs and exacerbated worker circumstances

FIGURE 2.2: SCAG 2016 TRUCK FORECAST COMPARING 2012 AND 2040 TRUCK TRAFFIC

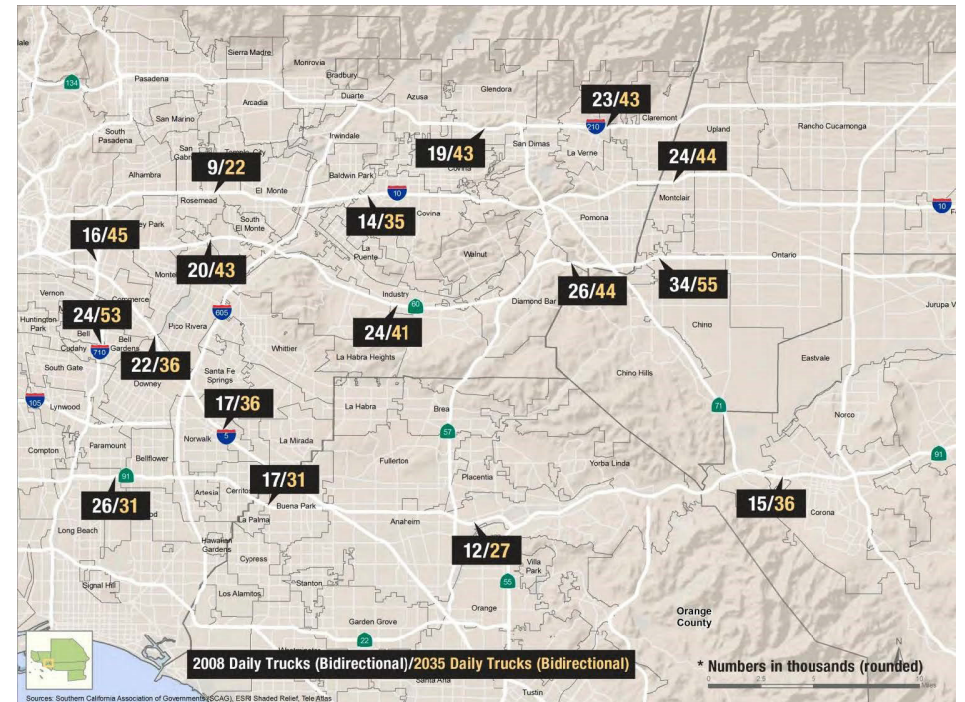

Source: SCAG 2012 & 2016 RTP/SCS

in some respects. Corporations, legislators, workers, and neighborhood activists are living out this global world within their personal experience. Ideals such as social responsibility, civic participation, and community-based projects are necessary to not just mitigate, but prevent denigrating outcomes for marginalized populations -- whether in Pomona or Phnom Penh. The global supply chain has brought people closer to their products and information through advanced technology, but should pay special attention to the consequences.

HISTORY OF SUPPLY CHAIN LOGISTICS IN SOUTHERN CALIFORNIA



Regional and international neoliberal economic policies have fostered international trade and globalization. Currently, these policies are based upon continued economic inequality, a lack of concern for sustainability, and little to no emphasis on community power.

The timeline highlights major events in the development of the Southern California logistics system, which have either mitigated or further increased economic inequality and a lack of sustainability and community power. The timeline includes some pertinent labor negotiations, environmental policies, and the construction of regional infrastructure related to supply chain logistics in Southern California.



1900s



1903 The Teamsters Union is founded as part of a merger of two leading team driver associations. Currently, the Teamsters represent numerous occupations including freight drivers and warehouse workers (Teamsters, 2016).

1907 The Port of Los Angeles (POLA) is founded along with the creation of the Los Angeles Board of Harbor Commissioners, developed to oversee the management and operations of POLA. The Los Angeles Board of Harbor Commissioners is comprised of five members appointed by the Mayor of Los Angeles and confirmed by the Los Angeles City Council (POLA, 2016).

1910s



1911 The Port of Long Beach (POLB) is founded (POLB, 2016).

1914 The Panama Canal opens--greatly reducing the distance ships travel between the Atlantic and Pacific Oceans, altering world trade patterns (Panama Canal Authority, 2016).

1917 The Long Beach Board of Harbor Commissioners is formed to create policy and oversee harbor operations at POLB. Similar to the commissioners of POLA, the five Long Beach Harbor Commissioners are appointed by the Mayor of Long Beach and confirmed by the City Council (POLB, 2016).

HISTORY OF SUPPLY CHAIN LOGISTICS IN SOUTHERN CALIFORNIA

1940s



1948 23 countries agree to the General Agreement on Tariffs and Trade (GATT) to rationalize international trade through the reduction of tariffs and other trade barriers. The agreement lasted until the establishment of the World Trade Organization (WTO) in 1995 (GATT, 1986).

1949 The Pacific Maritime Association (PMA), which includes representatives of employers from the shipping industry, was founded to negotiate and administer maritime labor agreements with the International Longshore and Warehouse Union (ILWU) (Pacific Maritime Association, 2015).

1950s



1956 Malcom McLean introduces the modern intermodal container, the first container designed for more than one mode of transportation. This new technology revolutionized the logistics industry, leading to greater efficiencies portside and a reduced demand for port labor. The expanded use of the intermodal container was immediately felt by port workers as fewer workers were necessary for loading and unloading cargo. This shift led to major struggles between labor unions and shipping companies, resulting in a substantial drop in the number of dock workers worldwide (Tomlinson, 2009).

1960s



1960 The Mechanization and Modernization Agreement of 1960, an agreement reached by the ILWU and the PMA, paved the way for containerized cargo at the Ports of Los Angeles and Long Beach. The agreement guaranteed registered longshoremen payment for a specified number of hours per week along with retirement benefits and compensation during union-caused work stoppage (Winter, 1986).

INTERMODAL CONTAINERS AT THE PORT OF LOS ANGELES



Source: Diane Benitez, Port of Los Angeles Site Visit

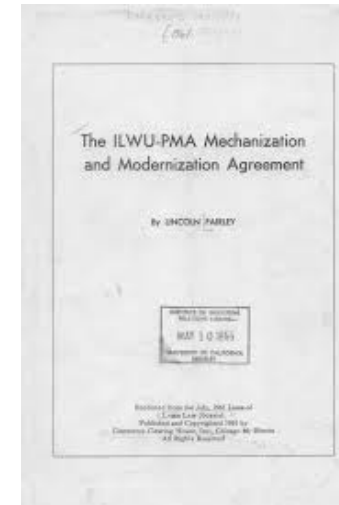

MECHANIZATION & MODERNIZATION AGREEMENT OF 1960

Source: UC Berkeley

HISTORY OF SUPPLY CHAIN LOGISTICS IN SOUTHERN CALIFORNIA

1961 The International Organization for Standardization recommends standardized dimensions and ratings for intermodal containers. The two most common international container sizes include twenty-foot equivalent units (TEUs) and forty-foot equivalent units (FEUs) (World Shipping Council, 2016).

1980s



1980 The US Motor Carrier Act of 1980 partially deregulated the trucking industry by limiting the Interstate Commerce Commission's (ICC) authority over motor carriers and drastically de-unionizing drivers. Both the Teamsters Union and the American Trucking Associations strongly opposed the deregulation. The act eliminated most restrictions on commodities that could be carried, the routes motor carriers could use, and the geographic region motor carriers could serve (Moore, 1993).

1990s



1994 The North American Free Trade Agreement (NAFTA) takes effect between Canada, Mexico, and the United States (Villarreal, 2010).

1995 The World Trade Organization (WTO) is created to facilitate free trade by mandating mutual "most favored nation" trading status between all signatories (World Trade Organization, 2016).

2000s



2002 Following the PMA facilitated 10-day lockout of ILWU members from the POLA and POLB, the ILWU and the PMA agreed to introduce computerized processes into port operations. The agreement allowed the use of optical scanners, remote cameras and other freight tracking equipment within both Ports. In exchange, the PMA agreed to ensure all port operation jobs would be union-covered and savings from automation would be directed toward ILWU pensions (Greenhouse, 2002).

FORMER PRESIDENT BILL CLINTON
SIGNS NAFTA LEGISLATION, 1994



Source: History.com

HISTORY OF SUPPLY CHAIN LOGISTICS IN SOUTHERN CALIFORNIA

2004 Terminal operators in POLA and POLB unveil the PierPASS appointment system, designed to ease traffic congestion and reduce air pollution by shifting a portion of truck trips to nights and weekends (PierPASS, 2016).

2006 POLA and POLB jointly release the San Pedro Bay Ports Clean Air Action Plan, a comprehensive strategy to reduce air pollution and health risks produced by the two ports. In the plan, POLA and POLB committed to reduce pollution by 45 percent within five years. The plan was updated in 2010 and introduced new pollution reduction goals for the following decade (Clean Air Action Plan, 2016).

2008 The ILWU and the PMA agree to allow automation in port terminals in the form of computer-controlled ship-to-shore cranes, unmanned horizontal ground transportation and automated stacking cranes (Mongelluzzo, 2016).

2008 POLA and POLB launch the Clean Truck Program, which was originally developed to replace diesel trucks with cleaner fuel vehicles and shift the status of truck drivers from independent contractors to employees of trucking companies. The program has removed thousands of diesel emitting trucks from the roads, but litigation from the trucking industry prevented truckers from completely shifting from independent contractors to employees (Dreier, 2011).

2009 Port of Long Beach's Middle Harbor project gets approved by city council. Middle Harbor is a partially automated terminal that is expected to achieve full automation by 2019. The ILWU has expressed concern about the loss of jobs associated with automation (Mongelluzzo, 2016).

2010s

2012 Organized by the Warehouse Workers Resource Center, warehouse workers from Walmart distribution centers walked 50 miles in protest of the conditions of their workplaces, ending at Los Angeles City Hall (Brennan, 2012).

2014 POLA initiates the first phase of the automation of the TraPac terminal, which upon completion, will be a fully automated terminal. A POLA study found that 40 to 50 percent of jobs at the TraPac terminal will be eliminated once the facility is fully automated (Mongelluzzo, 2016).

2015 The ILWU reached a tentative agreement for a new 5-year contract with the Pacific Maritime Association (PMA); the agreement includes maintaining health benefits for workers and pensioners, continued ILWU jurisdiction for inspecting chassis units at the ports, and improving the arbitration system that mediates on-site disputes between the unions and the PMA (Edwards, 2016).

BENJAMIN FRANKLIN DOCKS AT THE PORT OF LOS ANGELES



Source: CMA CGM Blog

2015 French container transportation and shipping company CMA CGM docks Benjamin Franklin at the Port of Los Angeles, this is the largest container ship to call at a North American Port; the Benjamin Franklin is capable of carrying 18,000 twenty-foot equivalent units (TEUs) (Cox, 2016).

2015 Warehouse workers from the California Cartage Company, a warehouse located at POLA, protested labor practices, wage theft, and unfavorable working conditions. The strike was not supported by the ILWU but was joined by the Teamsters (Watt, 2015).



3

THE INLAND PORT

SAM APPEL, DIANA BENITEZ, ADRIANA QUIQUIVIX, & DYLAN SITIG

THE INLAND PORT

Strategic Interventions for Social Equity, Sustainability, & Community Power

1

ALIGN EXISTING REGULATORY TOOLS

Municipalities should align existing regulatory tools, including CBAs, Green Zones, and CalOsha regulations, for local implementation in an Environmental Justice Element to minimize harms of warehousing and infrastructure development, and improve jobs.

2

GOODS MOVEMENT OVERSIGHT BOARD

The California state legislature should create a Goods Movement Oversight Board (GoMOB) similar to the existing Coastal Commission that would assume regional project permitting and planning authority over goods movement development and infrastructure. Board members would be majority community residents and workers to ensure that environmental justice and worker rights at the forefront of decisions.

3

TAXES ON INDUSTRY-USERS OF TRANSIT INFRASTRUCTURE



Federal, state and local governments should implement additional taxes on industry-users of public transportation infrastructure to offset negative externalities, and allow communities decide how to implement spending plans and mitigations.

4

REALIGN PUBLIC INVESTMENTS

Federal, state, regional, and local transportation agencies should realign public investments to offer reparations for past harms related to infrastructure and to subsidize transit and sustainable economic development goals.

INTERVENTIONS KEY

-  Social Equity
-  Sustainability
-  Community Power

CHAPTER 3: THE INLAND PORT

INTRO TO THE INLAND PORT

This chapter considers the effects of the goods movement system on workers and communities in inland areas of Southern California and interventions to shift political power into their hands. This chapter begins with an analysis of existing conditions and trends, providing an overview of current demographics and policies related to the inland port. Next, interventions are put forward to achieve a more just, equitable, and sustainable goods movement system in inland areas.

WHAT IS AN INLAND PORT?

An inland port is a catchall for areas with a concentration of warehouses, distribution centers, intermodal facilities, and transportation infrastructure (i.e. rail, highways, and potential future dedicated right-of-ways) (Newman, 2012). This term applies to various parts of Los Angeles, San Bernardino, and Riverside counties with high concentrations of such facilities and infrastructure. Western parts of San Bernardino and Riverside Counties are referred to in this chapter as the Inland Empire.

EXISTING CONDITIONS & TRENDS

The Southern California region is home to one of the largest clusters of warehousing and distribution facilities in the world, with about 1.2 billion square feet of warehousing space including distribution centers, cold storage and truck terminals (SCAG, 2015, Newman, 2016). Port-related warehouses are located along goods movement corridors in the Gateway Cities, the City of Industry, and in the Inland Empire (see **Figure 3.1**) (SCAG, 2015). Goods movement corridors connecting Los Angeles and Inland Empire facilities—including warehouses, and intermodal yards—are part of a larger regional logistics system made up of more than 70,000 roadway lane miles, hundreds of miles of Class 1 railroad track, the largest port facility in the US, and major intermodal facilities (Hayes, 2016).



Source: California Cartage, 2015

CALIFORNIA
CARTAGE
WAREHOUSE
WORKERS WALK
OUT ON STRIKE IN
OCTOBER 2015.



Source: Goetz Wolff, Costco Distribution Center in Mira Loma, CA

COSTCO WAREHOUSE IN MIRA LOMA, CA

Experts consider the Los Angeles and Inland Empire logistics systems to be one and the same due to its shared origin point of the ports of Los Angeles and Long Beach (Husing, 2016, Kaoosji, 2016). However, this report makes a distinction between the two regions--in particular, the differences in political context and power dynamics. Past research on warehousing in the Southern California region has focused on the Inland Empire with limited information on Los Angeles warehousing. This chapter of the report provides an overview of warehouse facilities, inland port infrastructure development, demographics of warehouse workers and surrounding communities, environmental burdens, and the policy and political environment of the two regions.

WAREHOUSE LOCATIONS, SPATIAL TRENDS, EXPECTED GROWTH

Over the 109-year existence of the Ports, warehousing has largely been confined to LA county, until the last three decades (see **Figure 3.2**) (Port of Los Angeles, n.d.) According to John Husing, regional economist for pro-industry advocacy group the Inland Empire Economic Partnership, distribution center and warehouse developers began acquiring industrial land outside LA County, in Ontario, Chino, and Mira Loma, beginning in the mid-80s. LA County's industrial zones are concentrated in cities like the City of Industry, Commerce, and Vernon and became increasingly built out (Husing, 2016). By 2000, developers were purchasing land further

Figure 3.2: Concentration of Warehouses in Inland Valleys vs. Los Angeles Region

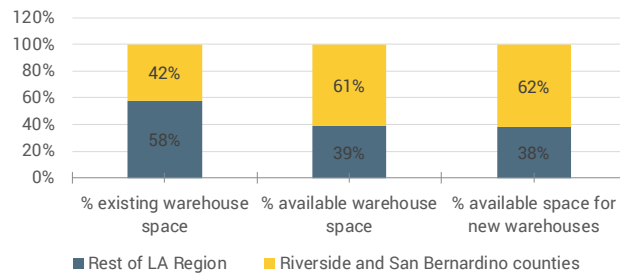

Source: Bentacourt & Valianatos, 2012

Figure 3.1: Existing Warehouses in Southern California Region

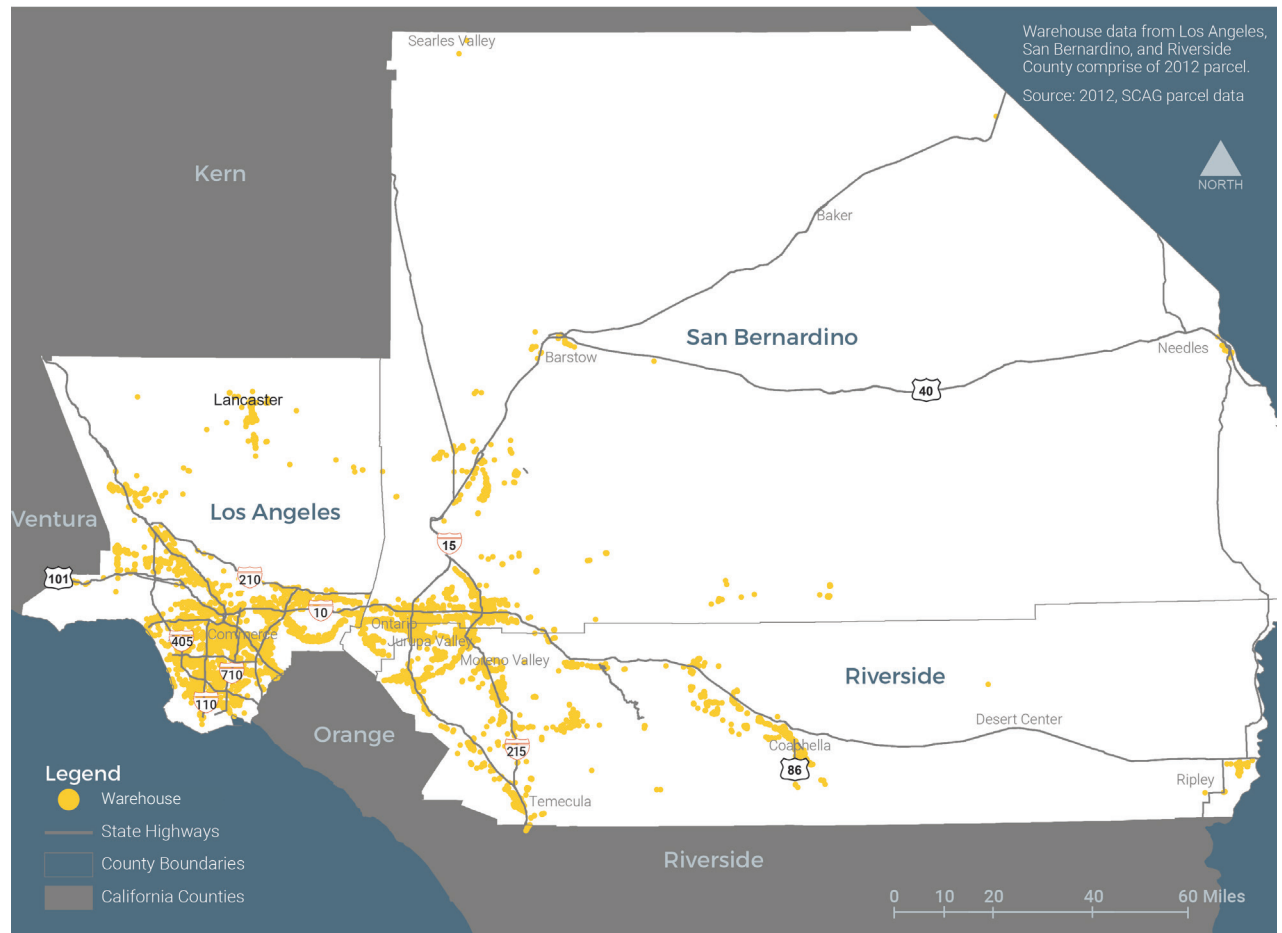

east down the 10 freeway in Rialto and Colton. More recently construction has moved into Redlands and San Bernardino and down the 60 through Moreno Valley towards Beaumont. Development is also moving down the 215 towards Perris (Husing, 2016).

The rate of warehouse and DC growth is now at a cyclical high (Smith, 2015). After a bust coincident with the 2008 housing bubble, the LA regional warehousing market is now showing as many square feet under construction, and as much warehousing space absorbed, as during the 2007 market peak (Transwestern, 2016). To give a sense of the scale of growth, at the end of the first quarter of 2016, 52 buildings were under construction in the Inland Empire. These buildings amount to 15.1 million square feet, with a nearly equal amount of growth occurring in the west and east portions of the Inland valley. The real estate firm CBRE predicts that 18 million square feet of warehousing space will be delivered by the end of the year (see **Figure 3.3**) (Durnin, Moler, & Harkness, 2016).

The hottest submarkets for warehouse and DC growth over the last year, according to CBRE, have been Fontana, Rancho Cucamonga, and Ontario (Durnin, Moler, & Harkness, 2016). These submarkets, and the overall market, are hot for largely three reasons. One is the continuing surge of imports, and expected growth of imports, coming through the Ports, which need to be stored or transloaded. 2016 is forecasted to be the busiest year ever at the Ports (Los Angeles Business Journal, 2016). The second is the superiority of IE infrastructure linkages to the Ports. Lancaster would be the next best location to warehouse imported goods, but transportation connections are inferior, and unlikely to improve significantly (Husing, 2016). Finally, e-commerce is booming, and so with it the need for massive new distribution centers. Amazon alone built six distribution centers in the inland empire in the last decade. In 2015 overall, the IE market saw 112 e-commerce “deals” totaling 34 million square feet of space (see **Figure 3.4**). This market represents a significant and growing industrial market for the region (Harkness, 2016).

Figure 3.3: Metro Inland Empire Historical Sales Transactions

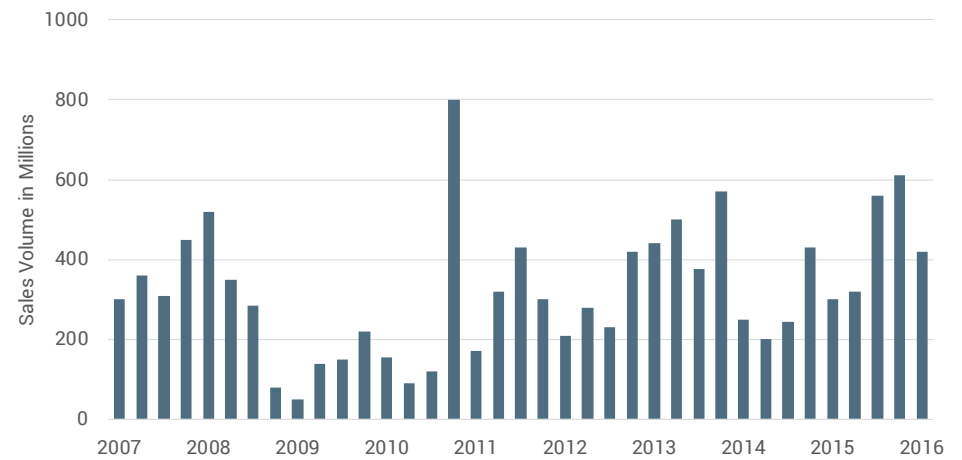

Source: Transwestern, 2016

Figure 3.4: Size of E-commerce Distribution Centers

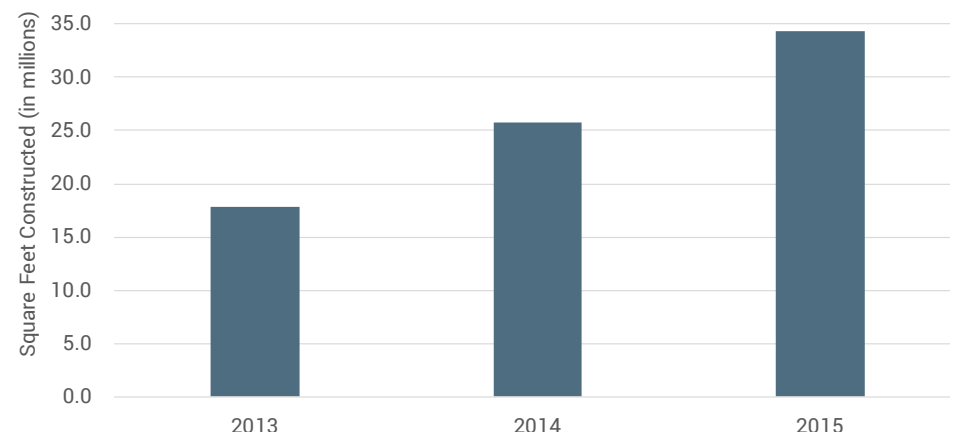

Source: Durnin, Moler, & Harkness, 2016

EXISTING WAREHOUSES

The following analysis uses 2012 parcel data provided by SCAG for Los Angeles, San Bernardino, and Riverside counties. The warehouses identified are based off the land use descriptions which vary by county. Los Angeles, for example, defines their warehouses by size in the following categories: below 10,000 square feet; above 50,000 square feet, and warehousing/distribution/storage. San Bernardino and Riverside counties separate their warehouses by type. The warehouses illustrated in the San Bernardino county map include transit, storage, and distribution centers. Riverside County uses industrial storage and manufacturing and processing.

The maps below illustrate what the literature repeatedly says about the geographic distribution of warehouses; they are highly concentrated along the major corridors connecting the goods movement from the ports inland. The following descriptive analysis highlights the number of warehouses by type of warehouse per county as well as the five cities in each county with the highest square footage dedicated to warehouse space. The purpose of highlighting these five cities per county is to point out that areas, because of their high concentration of warehousing space, are likely

to be cities with higher levels of diesel exposure due to traffic density (U.S. EPA, 2014). As explained further following this analysis, high levels of diesel exposure cause residents nearby great health risks.

Los Angeles County has 8,291 warehouses; 1,640 are over 50,000 square feet, 6,582 are less than 10,000 square feet, and 70 locations are defined as warehousing/ distribution/ storage (SCAG, 2012). The Los Angeles County **Figure 3.5** shows how these warehouses are geographically distributed with clear clusters located in Commerce, Vernon, Carson, Industry and Santa Fe Spring areas. The map also makes visible a smaller concentration of warehouses along the Interstate-5. These aforementioned cities are among those with the most land dedicated to warehousing.

Figure 3.5: Overview of Warehouses in Los Angeles County

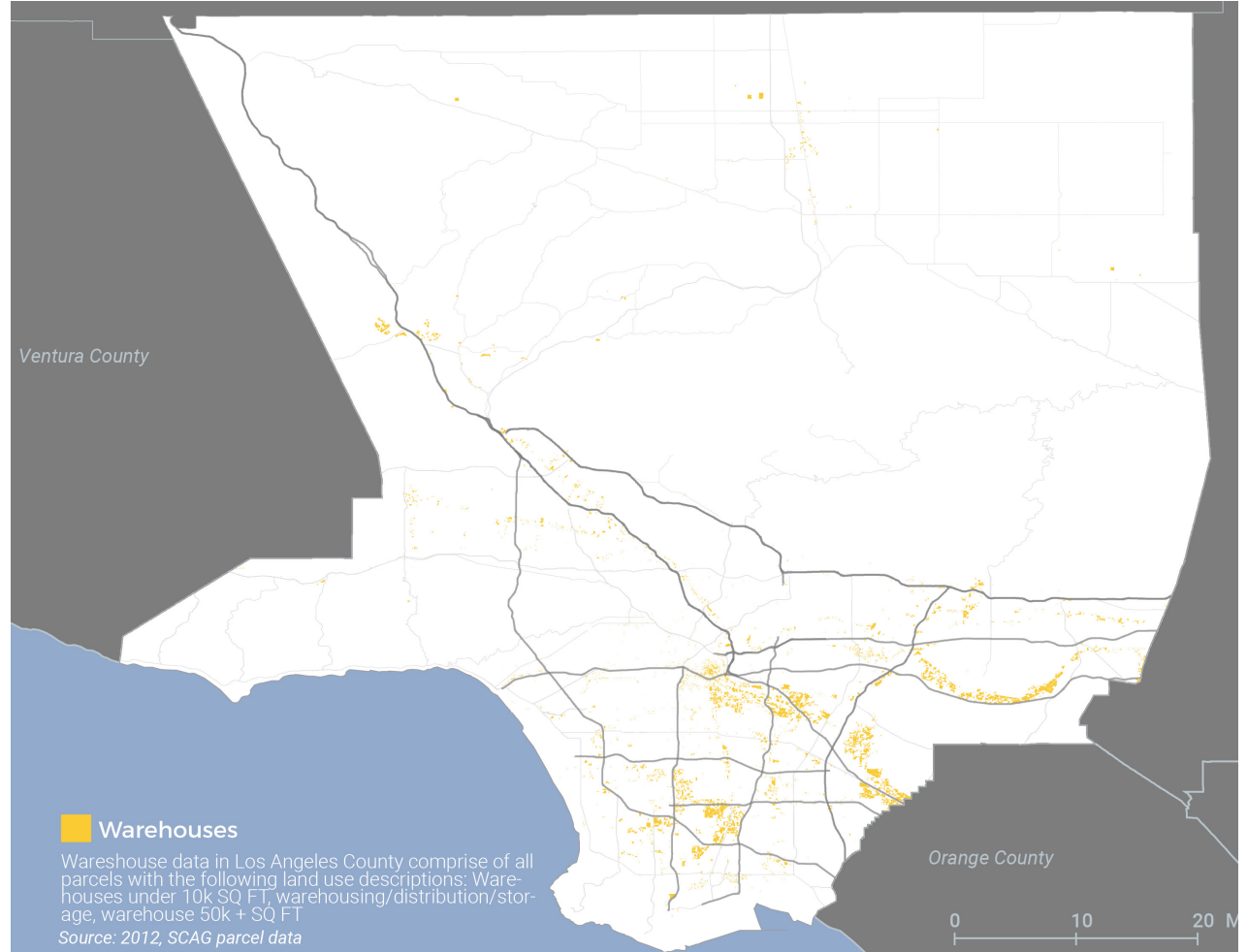

Table 3.1 lists the five cities in the county with the most space in square feet dedicated to warehousing.

Table 3.1: Cities in Los Angeles County with the Most Square Feet Dedicated to Warehousing

City	Warehouses (SF)
Industry	64.9 million
Santa Fe Springs	57.9 million
Los Angeles	46.9 million
Carson	46.3 million
Commerce	44.7 million

Source: SCAG, 2012

Moving further east, San Bernardino County has 2,661 warehouses; 60 are transit warehouses, 1,963 are storage warehouses, and 638 are distribution centers (SCAG, 2012). San Bernardino County is the largest county in California, with most of the population concentrated at the southwestern border. Similarly, the warehouses are also concentrated on the southwestern border adjacent to Riverside County (See Figure 3.6).

Further, the cities within San Bernardino County with the highest amount of space dedicated to warehousing vary by the type of warehouse as seen in Table 3.2.

Figure 3.6: Overview of Warehouses in San Bernardino County

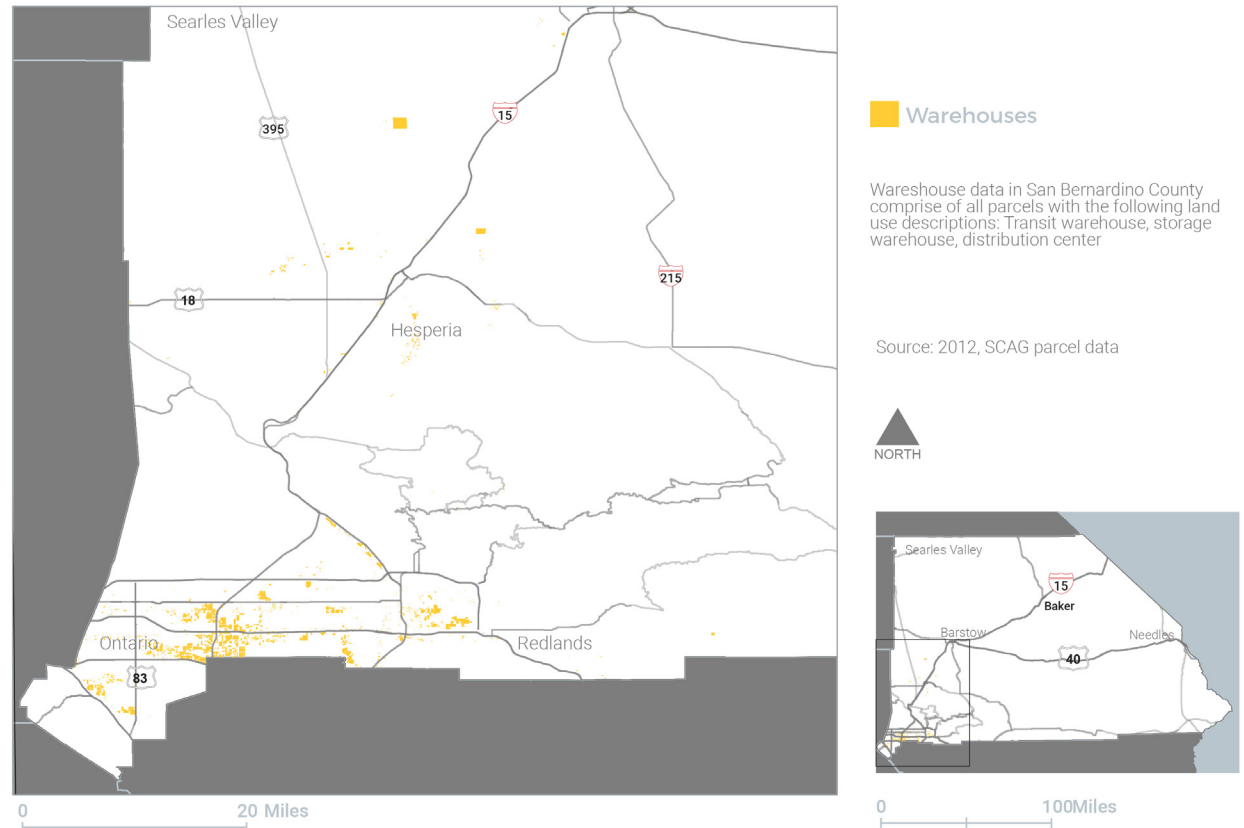

Warehouses

Warehouse data in San Bernardino County comprise of all parcels with the following land use descriptions: Transit warehouse, storage warehouse, distribution center

Source: 2012, SCAG parcel data

NORTH

0 100 Miles



AMAZON FULFILLMENT CENTER IN SAN BERNARDINO

Source: Chino Proud Digital Media Network, published April 11, 2016

Table 3.2: Cities in San Bernardino County with the Most Square Feet Dedicated to Warehousing

City	Transit Warehouse (SF)	City	Storage Warehouse (SF)	City	Distribution Center (SF)
Fontana	10.7 million	Adelanto	59.9 million	Ontario	101.7 million
Bloomington	4.3 million	Apple Valley	2.0 million	Fontana	52.4 million
San Bernardino	2.9 million	Baker	2.0 million	San Bernardino	37.3 million
Rialto	1.9 million	Barstow	1.6 million	Rancho Cucamonga	36.1 million
Barstow	1.2 million	Big Bear City	71 thousand	Chino	29.9 million

Source: SCAG, 2012

Regarding transit warehouses, the City of Fontana dedicates the highest amount of space to this category--over 10.5 million square feet. Over one third of the space dedicated to storage warehouses in San Bernardino County is located in Adelanto. Finally, Ontario has the most land dedicated to distribution centers, with almost twice as many square feet than the second highest city, Fontana.

Riverside County is south of San Bernardino County and east of Los Angeles County. It has 6,096 warehouses; 1,125 are industrial storage warehouses and 4,970 are manufacturing and processing warehouses. Similar to San Bernardino County, the warehouses are concentrated along major corridors and their intersections. Specifically, **Figure 3.7** shows a cluster of warehouses at the intersections of the 215-interstate highways right by the City of Riverside and University of California Riverside. Other major clusters also exist in the Jurupa Valley, Corona, Moreno Valley, Murrieta and Temecula areas.

Figure 3.7 Overview of Warehouses in Riverside

Warehouses
 Warehouse data in Los Angeles County comprise of all parcels with the following land use descriptions: Manufacturing & Processing, and Industrial Storage
 Source: 2012, SCAG parcel data

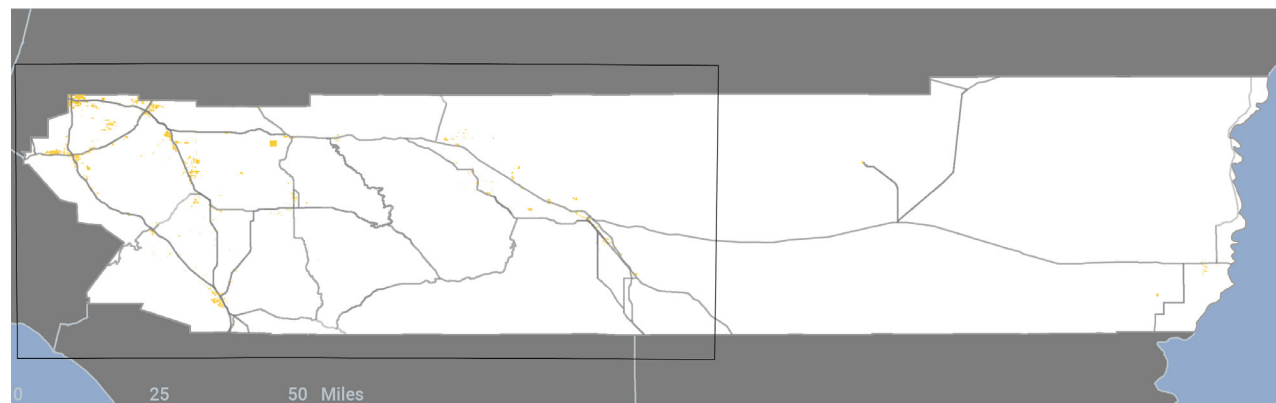
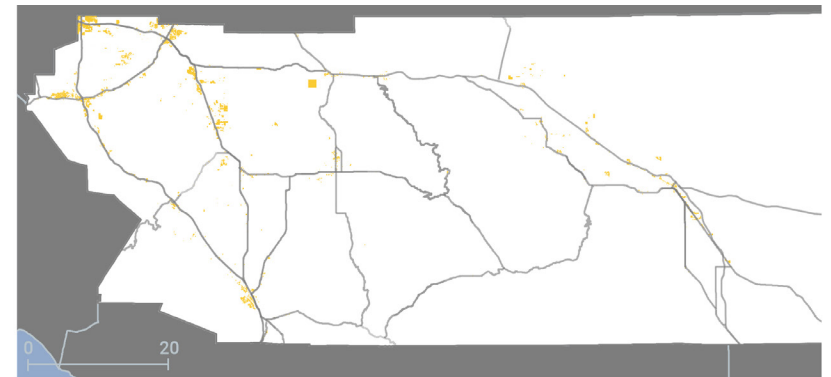

Table 3.3 lists the top five cities in Riverside County with highest square feet dedicated to warehousing. As mentioned earlier, warehouse clusters are the most prominent in the City of Riverside followed by Mira Loma for industrial storage warehouses and Corona for manufacturing and processing warehouses.

Table 3.3: Cities in Riverside County with the Most Square Feet Dedicated to Warehousing

City	Industrial Storage (SF)	City	Manufacturing and processing (SF)
Riverside	33.8 million	Riverside	134.3 million
Mira Loma	21.1 million	Corona	82.8 million
Perris	17.2 million	Mira Loma	54.9 million
Moreno Valley	14.8 million	Temecula	26.5 million
Desert Hot Springs	9.4 million	Perris	24.4 million

Source: SCAG, 2012

INLAND PORT INFRASTRUCTURE DEVELOPMENT

Infrastructure is the backbone of logistics commerce. Publically constructed or permitted routes and nodes--in the form of highways, intermodal yards, ports, rail infrastructure, county and city roads--enable or disable the flow of goods through Southern California. Mostly funded by billions of dollars in regressive county sales taxes--marketed to the public as public transit and congestion relief measures--these projects subsidize industry expansion, while leaving communities with greater environmental burdens and traffic (Economic Analysis Branch Division of Transportation Planning California Department of Transportation, 2015). The involvement of public financing, however, offers a unique opportunity for communities and labor to make demands on government for social equity, sustainability, and decisive power in the financing process and infrastructure regulation (Kaoosji, 2016).

ANALYSES OF PROJECTS BY TYPE

Four major types of public infrastructure projects are discussed to offer a lens on how public agencies might leverage change. Funding sources, the lead agency, and the project phase help dictate the level of key project components, including grade separation, arterial widening, highway expansion, and intermodal facility expansion projects. A map of the case study projects is provided in **Figure 3.8** on the following page.

COSTCO WAREHOUSE IN MIRA LOMA

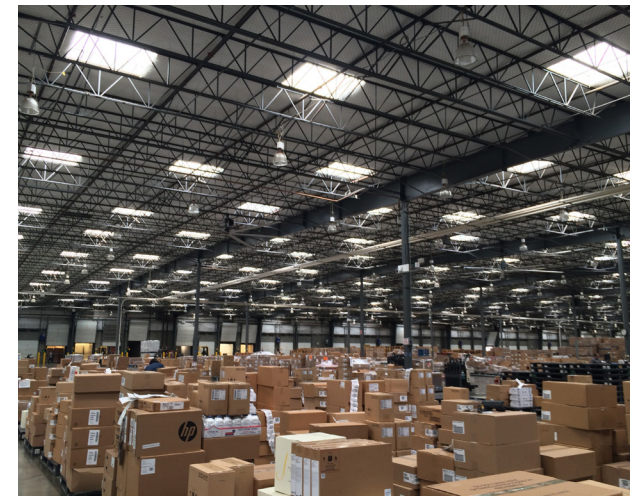

Source: Edber Macedo, Costco's Mira Loma Distribution Center

“Mostly funded by billions of dollars in regressive county sales taxes -- marketed to the public as public transit and congestion relief measures -- these projects subsidize industry expansion, while leaving communities with greater environmental burden and traffic.”

Economic Analysis Branch Division of
Transportation Planning CA Department of
Transportation, 2015

Figure 3.8: Diesel Particulate Burden at Riverside Underpass, Washington Blvd Arterial, Devore Interchange, and Southern California Logistics Center

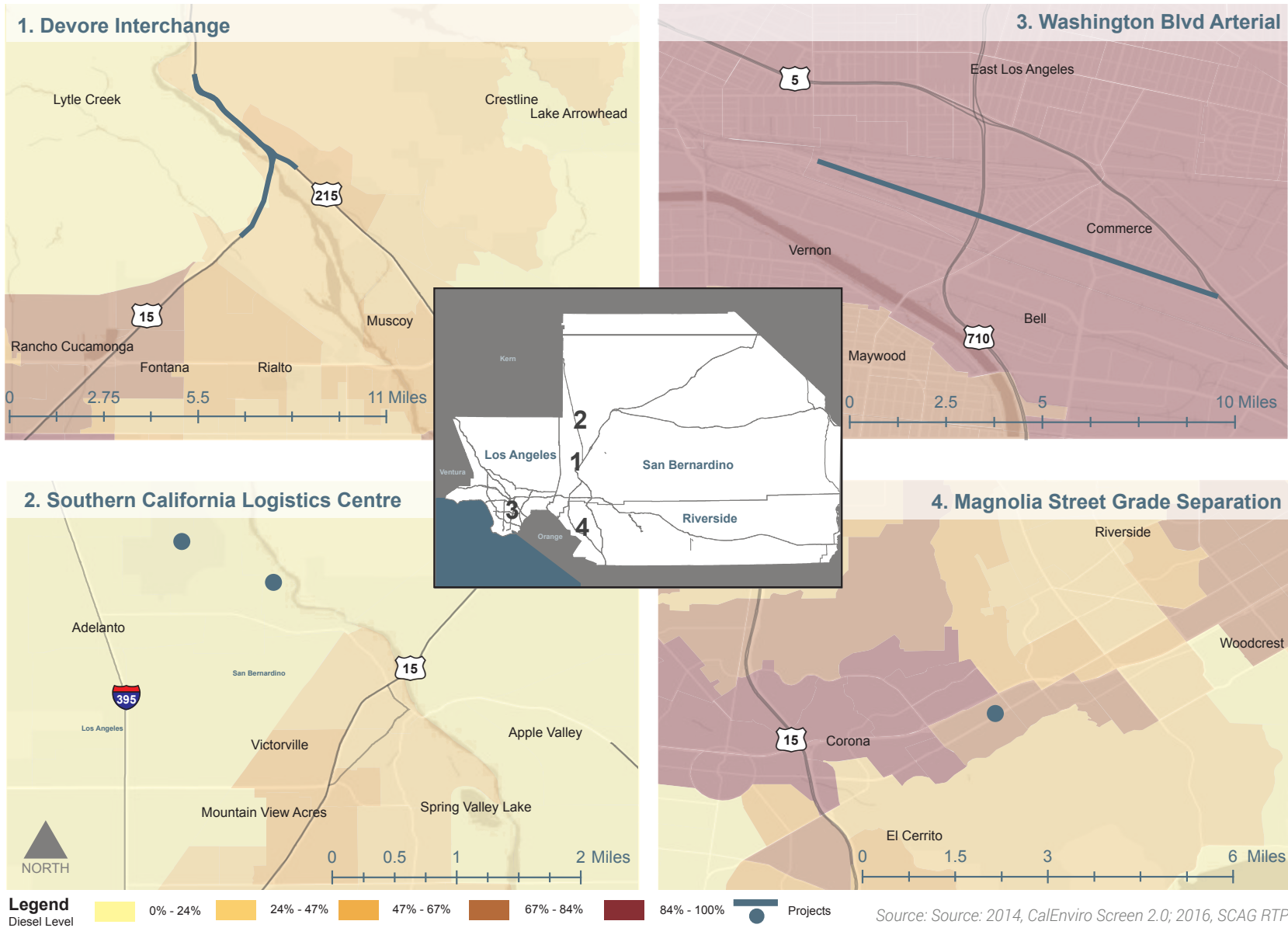

GRADE SEPARATIONS

Grade Separations aim to divide “two intersecting axes of traffic”—usually a highway and a rail, or two rail lines—by elevating one above the other. Their purpose is to reduce wait times at rail crossings, and emissions from idling vehicles (SCAG, 2015). Separations add value for rail and trucking companies, which benefit from minimized corridor delays (Wachs, 2016). In SCAG’s “financially constrained” cost estimates, Southern California governments, the state, and the federal government will pay \$4.9 billion for grade separations between now and 2040. These projects comprise half of projected rail enhancement projects by expenditure amount (SCAG, 2015).

CASE STUDY: RIVERSIDE AVENUE UNDERPASS GRADE SEPARATIONS

LOCATION

Riverside Avenue Union Pacific At-Grade Rail Crossing, City of Riverside

LEAD AGENCY

Riverside County Department of Transportation

PROJECT PHASE

Completion (20 months)

CONSTRUCTION COST ESTIMATE

\$33,080,000

FUNDING SOURCES

Prop 1B Trade Corridor Improvement Fund (TCIF)

(\$12.1M); Riverside County Transportation Commission (RCTC) Design Advance Funds (\$1.5M); Riverside City (\$3.54M); State Section 190 Grade Separation (\$5M); Federal Funds (\$9.69M); UPRR Railroad Contribution (\$1.25M) (“Riverside Avenue Underpass Project at Union Pacific Railroad,” n.d.).

SUMMARY

Riverside County Transportation Department constructed a railroad underpass at the Riverside Avenue Union Pacific at-grade crossing. The project entails lowering the avenue 300 feet, constructing a new street and constructions a railroad bridge. According to the Riverside County Transportation Department, project goals include “eliminating train/auto crossing conflict; improving vehicle and pedestrian safety; reducing congestion and traffic delays; improving emergency services responses; [and] facilitating regional commercial and commuter rail transportation” (Riverside Avenue Underpass Project at Union Pacific Railroad, n.d.). This grade separation was identified as a “tier A” development priority by Riverside Transportation Commission (Riverside County Transportation Commission, 2012). RCTC estimates that 13.64 tons per year of greenhouse gas emissions (CO₂) will be eliminated by the project (“Riverside Avenue Underpass Project at Union Pacific Railroad,” n.d.).

ARTERIAL ROAD INVESTMENTS

Arterial road investments entail various forms of upgrading and expanding local streets and

roads, including widening, paving new streets, spot expansion, signal improvements, and driveway consolidation (SCAG RTP Highways and Arterials Appendix, 2012). Arterial roads constitute 80% of the total road network, and carry 50% of all traffic in Southern California, including a significant volume of freight seeking to bypass congested freeways, and navigating between freeways and logistics facilities. Improvements to arterials benefit industry by reducing truck delay. SCAG predicts that upwards of \$10 billion dollars in arterial public investment in LA, Riverside and San Bernardino counties, will reduce heavy duty truck delay on highways by 40% and on arterial roads by 55% by 2035 (“SCAG RTP Highways and Arterials Appendix,” 2012).

CASE STUDY: WASHINGTON BOULEVARD ARTERIAL WIDENING

LOCATION

Washington Boulevard from Indiana Street to the I-5 Freeway, City of Commerce.

LEAD AGENCY

City of Commerce

PROJECT PHASE

Construction

CONSTRUCTION COST ESTIMATE

\$32,000,000 (recently revised upward) (Washington Blvd Widening and Reconstruction Improvement Project, 2014, sec. Planning and Programming Committee)

FUNDING SOURCES

Prop 1B Trade Corridor Improvement Fund (\$5.8M); CTC Match (\$3.19M); Safetea-Lu Earmarks (\$2,440,000); Measure R Highway Funds (\$13.3M); City of Commerce (\$7M) (Agenda for the City Council of the City of Commerce, 2013, sec. Successor Agency To The Commerce Community Development Commission).

SUMMARY

The project widens a 2.7 mile segment of Washington Boulevard in the City of Commerce from two general purpose lanes in each direction to three general purpose lanes in each direction. The road is a critical goods movement trucking link between nearby intermodal rail facilities and the I-5 freeway. The project allows for an increased turning radius for the considerable number of trucks that use this road, thereby decreasing congestion, and allowing greater pass-through of trucks ("About Project | Washington Boulevard Construction Project," n.d.). The project also involves pavement repair, upgrading traffic signals, and creating new medians along Washington Boulevard (Washington Blvd Widening and Reconstruction Improvement Project, 2014, sec. Planning and Programming Committee).

HIGHWAY EXPANSION

Highway expansion entails the extension or widening of grade-separated, limited-access roadway systems, otherwise known as freeways. The purpose of highway expansions

is to increase capacity and alleviate bottlenecks along a corridor. The highway facility will accommodate higher traffic that in turn will alleviate highway congestion. Highway expansions can also include the construction of truck bypass lanes which intend to allow easier, smoother travel for large, heavy vehicles through the corridor. This is particularly useful for roadways with steep inclines or grades where trucks are unable to move at the speed of other traffic. By dedicating lanes to these vehicle types, it reduces the potential conflicts and hazards of passenger vehicles using the same facility.

CASE STUDY: DEVORE INTERCHANGE PROJECT

LOCATION

I-15 and I-215 Freeway Interchange, County of San Bernardino

LEAD AGENCY

Caltrans

PROJECT PHASE

Under Construction (2013 to Mid-2016)

CONSTRUCTION COST ESTIMATE

\$324,000,000

FUNDING SOURCES

Federal Funds (20%), San Bernardino County - Measure I Funds (24%); State Funds (56%) (Devore Interchange Project, 2013).

SUMMARY

San Bernardino Associated Governments (SANBAG) and California Department of Transportation (Caltrans) developed this project to address the traffic congestion in the area. The project adds one new freeway lane in each direction, two miles of truck bypass lanes, a new connector, and a number of new grade separated bridges. These additions would alleviate the average queue of traffic that extends at an average of five miles south of the interchange, which has been known as "one of the worst grade-related bottlenecks in the nation" (Devore Interchange Project, 2013). Construction began in 2013 and is expected to be complete by the end of 2016.

INTERMODAL FACILITIES EXPANSION

Intermodal facilities expansions are unique in that they encompass multiple modes of transportation at their facility. Most cases, they involve freight rail infrastructure and trucking. These are considered intermediate facilities and staging areas for goods to transfer from a long distance leg to a short distance leg. For example, intermodal facilities could be receiving goods from a local port via truck and be loaded onto rail for a cross-country trip. Conversely, this facility could accept goods via rail that will be transloaded to truck or air transport to a nearby or overseas location. With the rise in globalization, there will be a greater need for more, or bigger intermodal facilities to handle

future demand. The expansion of such facilities is often seen as a benefit to a region, but tends to place a disproportionate burden on the local communities. This is due to the increased rail, truck, and air traffic, which would also increase traffic, emissions, and pollution in a localized area.

CASE STUDY: SOUTHERN CALIFORNIA LOGISTICS CENTRE, RAIL EXTENSION

LOCATION

City of Victorville - San Bernardino County

LEAD AGENCY

City of Victorville

PROJECT PHASE

To be Completed by 2019

CONSTRUCTION COST ESTIMATE

\$250,000,000

FUNDING SOURCES

Federal Funds, Private Investment (SCLA, n.d.)

SUMMARY

In 2007, the City of Victorville improved the redevelopment of the Southern California Logistics Airport (SCLA), a 90,000-acre area. Currently, BNSF is building a rail connection to the eventual intermodal yard, Southern California Rail Complex (SCRC). The scope of this project is only to add the rail connection. The planned rail development will be a 430-acre intermodal yard that is adjacent to SCLA

and hundreds of acres of industrial sites in this facility. The listed incentives for companies to invest and locate in this area are city tax credits, reduced utility rates, tax-exempt bonds, and state tax assistance. Since the beginning of its development, over 100 companies have begun doing business in the facility (SCLA, n.d.)

WAREHOUSE WORKERS

The warehouse workforce plays a crucial part of the ports logistics system; but warehouse workers (often only temporarily employed) face exploitation from their employers and have little formal representation to address their grievances. After the longshore workers unload the cargo and truckers deliver the goods to each warehouse, the warehouse workers must efficiently cross-dock or transfer those goods onto the next step of the logistics system. Although the demand for goods continues to grow, warehouse owners still claim to struggle with staying above profit margins (Marks et al., n.d.).

As a result, many warehouse owners employ large portions of their workforce temporarily to cut costs. This employment model makes it more convenient for warehouse owners to match numbers of workers with fluctuating cargo loads. The warehouse workers must deal with the high costs of this model. Regardless of employee status, all warehouse workers work under the same safety and labor standards. The following factors affect the degree to

COSTO WAREHOUSE IN MIRA LOMA



Source: Goetz Wolff, site visit

COSTO WAREHOUSE IN MIRA LOMA



Source: Goetz Wolff, site visit

which warehouse workers experience hardship on the job: employment site, worker demographics, employee statuses, occupation within the warehouse, and union density. The following subsections go into further detail exploring warehouse worker conditions.

DEMOGRAPHICS

The following section provides an overview of worker demographics in the warehousing sector, represented by the North American Industrial Classification System (NAICS) Code 493 Warehousing and Storage. The data below comes from the University of Minnesota’s Integrated Public Use Microdata Series USA (IPUMS) which is a microdata set consisting of aggregated household surveys from the US Census and the American Community Survey. This is the most complete microdata available; however, official data does not provide information on work sites for temporary workers, thus data presented in this report excludes this workforce. Some industry observers have estimated that there are between 5,000 and 9,000 temporary workers working in Southern California warehouses (De Lara, 2013). Nevertheless, Los Angeles County warehouse workers (the focus of this section) can be generally characterized as Hispanic, non-citizen, immigrant, male, and have obtained low education levels.

Race and Ethnicity

Los Angeles County warehouse workers are 70.6% Hispanic, as seen in **Figure 3.9**. This is 50 percentage points higher than the national warehouse workforce, which is only 20.3% Hispanic. White workers are underrepresented in the Los Angeles County warehouse workforce (11.7%) compared to the national workforce (59.3%); however, whites still represent the second highest racial/ethnic group in the Los Angeles County warehouse workforce. These two Los Angeles County employment rates are mirrored for the State of California, but are less extreme when compared to the national average. The inclusion of temporary workers would have an unknown effect on the results of this data given the unknown size of the temporary workforce in the warehousing sector.

Figure 3.9: Racial/Ethnic Breakdown of Warehouse & Storage Workforce (2000-2013)

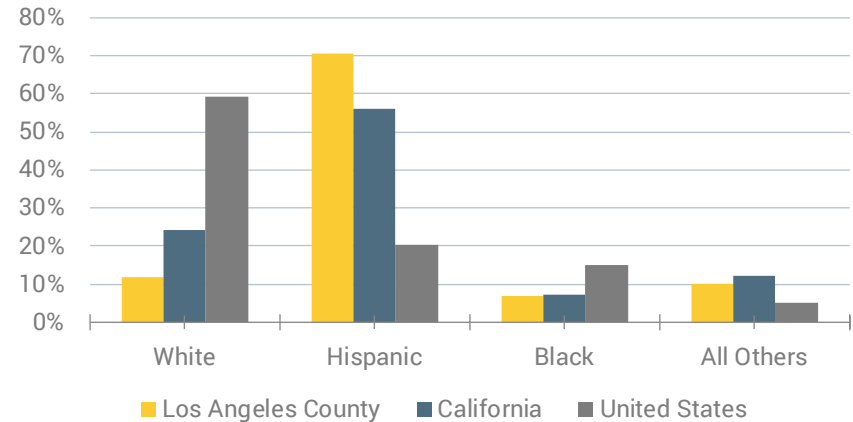

Source: IPUMS-USA, University of Minnesota

Figure 3.10: Immigration Status of Warehouse & Storage Workforce (2000-2013)

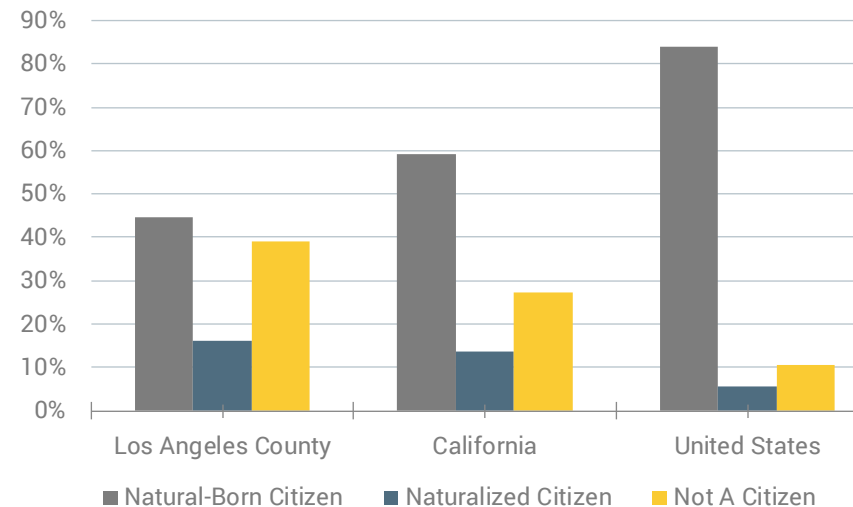

Source: IPUMS-USA, University of Minnesota

Figure 3.11: Educational Attainment of Warehouse & Storage Workforce (2000-2013)

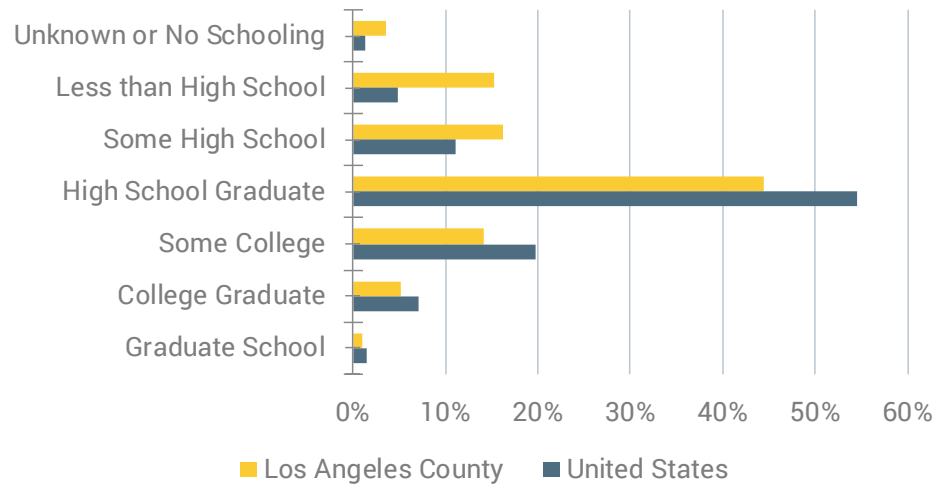

Source: IPUMS-USA, University of Minnesota

Immigration Status

As shown in **Figure 3.10**, 39% of Los Angeles County warehouse workers are non-citizens; this is 30 percentage points higher than the percent of national non-citizen warehouse workers. The state of California falls in the middle, with 27% of its warehouse workers as non-citizens. Again, this data does not include temporary workers. In Los Angeles County, 16% of warehouse workers are naturalized citizens. Thus, a majority of warehouse workers in Los Angeles County are immigrants. In the Inland Empire, half of warehouse workers are immigrants, half of whom are native-born (Allen, 2010). Most workers have the legal ability to work in the United States, but many still face harassment and threat of deportation (Allen, 2010).

When grouped by place of origin, the IPUMS data reveals that 38% of Los Angeles County warehouse workers were born in Mexico. This group is larger than native Californian warehouse workers (34.5%). Other major

Table 3.4: Education Levels

Job Group	Occupation	Educational Requirement
Managers, Business, & Financial	General & Operations Managers	Work experience plus degree
Clerical	Customer Service Representatives	Moderate-term OJT
Mechanics & Repairs	Bus, Truck & Diesel Engine Mechanics	Postsecondary vocational award
Other Transportation	Supervisors - Transportation & Vehicle Operators	Related work experience
Drivers	Truck Drivers, Heavy & Tractor-Trailer	Moderate-term OJT
Drivers	Truck Drivers, Light or Delivery Services	Short-term OJT
Warehouse	Industrial Truck & Tractor Operators	Short-term OJT
Warehouse	Laborers & Freight, Stock & Material Movers	Short-term OJT

Source: Belzer et al., n.d.

places of origin include other US states (9.5%) and Central America (and Caribbean) (9.2%).

Gender

Men comprise the majority of the warehouse workers at all geographic levels. In Los Angeles County, the IPUMS data reveals that men comprise 73% of warehouse workers. However, according to labor organizers working with warehouse workers, closer to 40% of warehouse workers are women (Struna et al., 2012). Missing data in official surveys on temporary workers may help explain this gap in gender employment rates. The physical demands of the work (Warehouse Workers United & Cornelio, 2011) may play into stereotypical gendered preconceptions and contribute to the overrepresentation of men in the industry.

Education Levels

Most Los Angeles County warehouse workers have attained a high school degree (44.5%) or less (see **Figure 3.11**). The levels of education found in Los Angeles County are on par with national levels, but slightly lower.

Very little formal education is required for the majority of occupations within the warehouse and storage industry (Belzer, Sedo, Herzenberg, & Swan, n.d.). As seen in **Table 3.4**, most of the occupations in the sector do not require any academic degrees or outside trainings; instead, on the job trainings (OJT) will usually suffice.

TEMPORARY WORKERS

According to the United States Department of Labor, “a temporary appointment is an appointment lasting one year or less, with a specific expiration date” (US Department of Labor, n.d.). In most cases, temporary workers are employed for the following reasons:

- To fill a short term position that is not expected to last more than a year
 - To meet an employment need that is scheduled to be terminated in the near future (one or more years) due to the constraints of a specific project
 - To fill positions that involve irregular or seasonal work schedules
- A temporary worker is not eligible for promotion, reassignment, or transfer to other jobs. Current law allows temporary employees to purchase health insurance after they have one year of temporary service, but the employee must pay the full cost with no government contribution. Temporary workers are eligible to earn leave and are covered by Social Security and unemployment compensation (US Department of Labor, n.d.).

For employers, the appeal of temporary work is obvious. Companies are able to meet peak consumer demand while also keeping their permanent workforce and associated costs (payroll taxes, benefits, workers’ compensation costs, legal liabilities, etc.) at a minimum (Jamieson, 2015). The use of temporary workers allows warehouse operators to avoid payment into workers’ compensation funds and to strategically prevent unionization efforts (Bonacich & Wilson, 2008).

WORKERS AT AMAZON FULFILLMENT CENTER IN SAN BERNARDINO



Source: Kurt Miller, Staff Photographer at The Press Enterprise

The number of temporary workers in the warehousing industry is unknown, but industry observers expect a sizable population of temporary workers in the warehouse industry, warranting specific study of this group. Nationally, temporary workers represented 2% of the workforce in 2014; the highest share recorded in US history (Greenhouse, 2014). Despite their significance in the national labor force, gathering data on temporary workers can be difficult due to the lack of required reporting from staffing agencies.

During a peak holiday season, Amazon uses an estimated 100,000 temporary seasonal workers to help meet demand (Jamieson, 2015). De Lara created various models which estimated that between 15 and 30% of temp workers are employed in blue-collar warehouse occupations; in total numbers, which puts between 4,500 and 9,000 workers in temporary blue-collar warehouse positions in Southern California region (2013). The Inland Empire has a higher concentration of temporary employment than the rest Southern California; in the Inland Empire, temporary employment increased 575% between 1990 and 2007 (Bonacich & De Lara, 2009).

Temporary workers are often mistreated and underpaid by their employers, but their role is essential to the corporate interests controlling the modern supply chain. As retailers have adapted to just-in-time distribution systems, they have created a flexible labor market to deal with the ebbs and flows resulting from cost-cutting measures such as reduced inventory and increasing speed to market (De Lara, 2013). A study in the state of Washington found that as a whole, temporary workers face lower pay and higher rates of injury compared to direct-hire workers (Grabell, 2013). Underemployment is also a major concern for temporary workers and results in significantly lower annual pay than direct-hire employees (De Lara, 2013).

SAFETY AND LABOR STANDARDS

“Warehouse workers do some of the most backbreaking jobs in our economy. Their work is often hidden from public view and there is constant pressure to work faster, which can lead to abuse” (Fryer, Deputy Director of Communications at the Department of Industrial Relations, & Ortiz, 2011, Deputy Labor Commissioner California Department of Industrial Relations).

Nationally, warehouse workers suffer one of the highest proportions of worker-related injuries and illnesses (Bureau of Labor Statistic, 2015). For example, one study published by the University of California, Riverside surveyed warehouse workers about their work-related injuries and illnesses. Unlike the Bureau of Labor Statistics, which gathers information from employers about all workers, this survey directly contacted temporary employees. Sixty five percent of the workers surveyed had suffered or witnessed an injury in the workplace (Marks et al., n.d.). High risk and labor intensive jobs

Warehouse workers do some of the most backbreaking jobs in our economy. Their work is often hidden from public view and there is constant pressure to work faster, which can lead to abuse.

Fryer, Deputy Director of Communications at the Department of Industrial Relations, & Ortiz, 2011

Table 3.5: Employment Level in Laborers & Freight, Stock, & Material Movers

City	Employment
Los Angeles - Long Beach - Glendale, CA Metropolitan Division	89.2k
Riverside - San Bernardino - Ontario, CA	45.5k

Source: Bureau of Labor Statistics, 2015

such as those requiring the manual movement of freight, stocking, operation of industrial trucks or tractors equipped to move materials around, packaging, etc (BLS, 2014), make up a large proportion of all warehouse occupations as seen in **Table 3.5** which further proves the dangers and importance of adequate training.

Yet, most of these occupations require little training or education, aside from the physical ability to complete the work. A documentary, titled "A Day's Work", clearly proves this practice in one of their scenes. In this scene, a person applying to a temporary position was asked to watch a 10-minute training video in English despite being open about his inability to speak English and was placed on the warehouse floor to work soon after. Cases such as this frequently occur and based on the aforementioned University of California, Riverside study, workers know this is widely common throughout the industry. Based on the survey results, only 23 percent of workers surveyed said they received adequate job training (Marks et al., n.d.). However, the need for a job coupled with a lack of knowledge regarding their rights as employees makes it easier for temporary workers to continue their unethical practices.

In addition to safety risks, warehouse workers also deal with unfair treatment due to pressure from the owner to move merchandise through the logistics system. These unsafe and unfair conditions of warehouse workers include failure to allow breaks, sexual harassment, pressure not to report an accident, lack of enforcement

Table 3.6: Mean Hourly & Mean Annual Wages in the Warehouse Sector

Occupation	Mean Hourly Wages			Mean Annual Wages	
	National	Los Angeles County	San Bernardino County	Los Angeles County	San Bernardino County
Transportation, Storage and Distribution Managers	44.8	44.5	-	93180	92570
Logisticians	36.94	39.98	-	76830	83170
First Line Supervisors, Machine and Vehicle	27.66	29.88	27.23	57530	62140
Laborers and Freight, Stock and Material Movers	13.07	13.26	13.23	27180	27580
Packers and Packagers	11.08	10.44	11.59	23040	21720
Temporary Workers	Unknown	Unknown	Unknown	Unknown	Unknown

Source: Bureau of Labor Statistics (2015), Occupational Employment and Wages, NAICS 493000 Warehousing and Storage

of existing laws and purposefully setting a confusing system for complaints to prevent workers from knowing who is legally responsible for their claims and wages, etc (Marks et al., n.d.; Warehouse Workers United & Cornelio, 2011). Furthermore, warehouse workers are treated differently based on work abilities and status such as ability to speak English, immigration status, and physicality (Allison, 2016; Marks et al., n.d.). Overall, warehouse workers in California are treated like second class citizens with low quality jobs and many times, in violation of basic rights.

At the moment, there is no policy program or incentive system encouraging warehouses to improve working conditions due to the surplus

of labor. There are very few promising policy openings emerging from union organizations in the Inland Empire to address workplace rights and labor conditions (Allison, 2016; Loveridge, 2016). One way to do so, according to Dr. Juliann Allison, from the Center for Sustainable Suburban Development, is to force temporary agencies that employ workers more than 30 hours per week to cover health care as is required by the Affordable Care Act. In the past, organizing warehouse workers, including temporary warehouse workers, has led to direct employment and therefore safer conditions in the workplace (Kaoosji, 2016).

WAGES

The following analysis of the Bureau of Labor Statistics Occupational Employment Statistics (2015) compares five different occupations found within the warehousing industry across the United States, Los Angeles County, and neighboring San Bernardino County, see **Table 3.6**. In general, all warehouse workers in Los Angeles County earn a higher mean hourly and mean annual wage than those in the United States, with the exception of distribution managers and packers. Wages in Los Angeles County also appear to be higher than San Bernardino County, with the exception of packers.

Among the occupations listed, which were selected to represent varying skill levels, distribution managers, logisticians and supervisors earn substantially more than laborers/movers and packers. First line supervisors earn more than twice that of laborers/movers and nearly three times as much as packers. Both laborers/movers and packers earn hourly wages approximately \$2 to \$5 less than the recently approved minimum wage, which the Los Angeles County Board of Supervisors voted to increase to \$15.00 per hour. Their annual wages amount to \$27,180 and \$23,040 respectively, fall short of the US Census Bureau's estimate for median per capita income in Los Angeles County, which is \$27,749 (US Census, 2014). Notably, these estimates do not include temporary workers who have been misclassified and may earn wages at different rates for similar work when compared to full

time employees. Recent studies on wages and the warehouse sector found that temporary warehouse workers earn \$10,067 annually; this is about half of the average annual full time temporary worker salary (De Lara, 2013). Temporary warehouse workers also earn about half of the average annual salary for direct-hire warehouse workers in logistics (De Lara, 2013). De Lara found that most of this wage disparity is driven by underemployment of temp workers.

Mean wage analysis provides context for regional differences in wages. However, many nascent warehouse workers face workplace discrimination and are withheld from the few advancement opportunities available in the industry. In particular, as demonstrated by a 2015 focus group in New Jersey, women are often only hired on a seasonal or as-needed basis to perform unskilled "pick and pack" type work involving walking the warehouse and fulfilling customer orders (Lindemann & Britton, 2015). This same focus group revealed that many unofficial barriers exist between what the focus group participants called "men's work" (lifting boxes and operating machines) and "women's work" (assembly line work) in the warehouses, thus preventing women from accessing higher paying jobs within the warehouses (Lindemann & Britton, 2015).

UNIONS

Unions are a vital part of the just transition of the goods movement system. Changes in the dynamics of warehousing and goods movement

Unions are a vital part of the just transition of the goods movement system.

systems overtime have diminished the role of unions. It is imperative that goods movement workers, at all levels of the supply chain, have the right and true ability to organize collectively to stem the tide of cost cutting measures taken by retailers, logistics firms, and other corporate interests which historically have fallen on the back of workers in the form of low pay and benefits.

The International Longshore and Warehouse Union (ILWU) began representing warehouse workers in the 1930s. In 1935, the ILWU began a "march inland" campaign to bring warehouse workers into the powerful Longshoreman's union. At the time, the warehouse workers were fought over by multiple unions, including the Teamsters. Industry restructuring as a result of the logistics revolution over the past few decades has led to "contingency-based employment, racialization, union loss, and low wages," (Bonacich & Wilson, 2008, p. 239).

Between 1983 and 2002, warehousing union density in California, Oregon, and Washington declined from 31% to 14%; during the same time period, warehouse work increased by roughly

65% (Rein, 2005). Part of this phenomenon may be described by the growth of the warehouse jobs in the Inland Empire, an area where powerful Los Angeles-based unions were not focused on organizing (Bonacich & Wilson, 2008).

Retailers and warehouse operators are interested in diluting Unions' presence to reduce wage related expenses. Labor accounts for 20% of total supply chain costs. A \$1 per hour raise in a warehouse with 500 workers can result in a raise in annual total labor costs at the facility by \$1 million. To recover this cost, a 500,000 sq. ft. warehouse would have to increase rent \$2 per sq. ft. representing a 37% increase in current average rental rates. Thus, there are major implications to the warehouse operator and renter of raising wages and a strong monetary incentive to prevent unionization of their workforce. (CBRE, 2016)

ORGANIZING EFFORTS

There is low union density within contingency-based, lower wage, and faster growing sectors of goods movement system (Rein, 2005). The few unions that do exist have been systematically weakened over time by the logistics revolution, corporate interests, and advances in technology, as discussed in Chapter II. However, there are multiple unions working to organize goods movement workers at many levels of the supply chain, including warehouses. Highlighted below are two cases from 2012 and 2015.

In the summer of 2012, workers began to protest unsafe working conditions brought on by the cutting of Walmart's logistics spending.

At the time, Walmart had begun to use staffing companies such as Schneider Logistics Inc., NFI, and Warestaff to hire temporary workers for warehouse positions (Lifsher, 2012). A lawsuit filed against Walmart's main staffing agency, Schneider Logistics Inc., accused the company of several labor violations, such as payment below minimum wage and long hours (Cho, Christman, Emsellem, Ruckelshaus, & Smith, 2012).

Additionally, warehouse workers were subjected to dangerous working conditions: "Workers are blocked inside dark, hot, metal shipping containers with inadequate ventilation with broken, unsafe equipment, under pressure to work faster; many get injured as they are required to lift up to 400 boxes an hour. There is little access to water. They are frequently denied breaks. Worse, supervisors yell at workers and tell them if their shirts are not drenched with sweat they are not working fast enough." (The Los Angeles County Federation of Labor, AFL-CIO, 2012)

In September 2012, warehouse workers from Walmart distribution centers walked 50 miles in protest of the conditions at their workplaces, ending at Los Angeles City Hall. The workers were organized by the Warehouse Workers United and were joined by many supporters and elected officials (Brennan, 2012). However, their protest for fair wages and working conditions continued well into 2013, as workers faced "extreme intimidation, spying and retaliation" for revealing the extreme conditions of Walmart warehouses (The Los Angeles County

Communities surrounding warehousing facilities in Southern California are primarily of Latino descent (55.15%).

*American Community Survey 5-year 2010-2014
Hispanic/Latino Race and Ethnicity (B03002)*

Federation of Labor, AFL-CIO, 2013b). Some, such as Javier Rodriguez, a forklift driver and advocate for better working conditions, were unlawfully terminated for speaking out against Walmart for the state of contracted warehouses (The Los Angeles County Federation of Labor, AFL-CIO, 2013a).

Most recently, in September 2015, there were strikes at the California Cartage Company in protest of "unfair labor practices, wage theft, and unsafe working conditions" (The Los Angeles County Federation of Labor, AFL-CIO, 2015). The California Cartage warehouse is located at the Port of Los Angeles, and serves many major retailers such as Amazon. While the first strike was not backed by the ILWU, the October protest saw warehouse workers joined by the Teamsters, in an interesting revival of a decade's old practice of labor organization support between closely linked industries. The move was particularly significant for the Cal Cartage workers, who until then had organized independently (Watt, 2015).

Organizing of warehouse workers has become difficult because of the pervasiveness of temp agencies. Organizing efforts that focus on a specific warehouse site may fail because temp workers can be rotated to different sites or the goods can be relocated to one of the many other warehouses in the area. Similarly, organizing efforts focused on a specific temp agency may fail because there are so many other temp agencies operating in the same area; in 2008, there were 270 temp agencies in one part of the Inland Empire (Bonacich & Wilson, 2008, p. 228). Thus, sector based organizing efforts may work best, but these broad efforts would require a significant amount of resources. Recently, the Teamsters have set their sights on organizing some port truckers and warehouse workers; this will involve a partnership with the Warehouse Workers Resource Center (Mongelluzzo, 2015). Local efforts by established unions, community groups, and groups like the Warehouse Workers Resource Center will be crucial in increasing sustainability, social equity, and community power. Additionally, national movements, such as those being led by the Alliance for the Temporary American Workforce, need to work to address problems that allow temporary staffing agencies to curb unionization efforts.

FRONT LINE COMMUNITIES

Front line communities are areas in which residents bear the impacts of living in close proximity to goods movement related facilities and infrastructure, whether distribution centers, port terminals, rail lines, intermodal yards,

Table 3.7: Overall County Residents v. Residents Living Near Warehouses by Race

County	Los Angeles		Riverside		San Bernardino		All Counties	
	County	Warehouse	County	Warehouse	County	Warehouse	County	Warehouse
Latino	48.15%	55.15%	46.54%	50.64%	50.52%	54.73%	53.13%	54.16%
Black	8.04%	9.38%	5.90%	5.47%	8.19%	8.90%	13.69%	8.50%
Asian	13.81%	12.39%	5.94%	4.90%	6.41%	5.48%	3.09%	9.73%
White	27.16%	20.42%	38.32%	35.80%	31.77%	27.90%	19.78%	24.78%
American Indian Native	0.18%	0.17%	0.45%	0.45%	0.36%	0.44%	0.00%	0.27%
Hawaiian/Other Pacific Islander	0.24%	0.27%	0.27%	0.26%	0.31%	0.30%	0.00%	0.27%
Other Race	0.25%	0.26%	0.17%	0.14%	0.23%	0.24%	0.00%	0.23%
Two or more Races	2.16%	1.96%	2.40%	2.35%	2.20%	2.01%	0.79%	2.05%

Source: Bureau of Labor Statistics (2015), Occupational Employment and Wages, NAICS 493000 Warehousing and Storage.

trucking warehouses, or freeways (Coronel et al., 2016; Prupis & Lazare, 2014). People who live, work, and go to school close to these sites inevitably breathe in toxic air spewed by diesel powered trucks, trains, ships, and other motorized equipment.

DEMOGRAPHICS

Literature discussing demographics of communities in which warehouses and distribution centers are sited primarily focus on specific cities or neighborhoods. One recent USC Metrans Center study considered race and proximity to warehouses across Southern California (Yuan, 2015). Communities surrounding warehousing facilities in Southern California are primarily Latino (55.15%). Note,

Latinos make up a large portion of the regional population which may impact descriptive data. All races, save for African Americans, are overrepresented in warehouse areas compared to countywide population density (see Table 3.7). Further analysis measuring parcel, race, and warehousing facilities at a smaller geographic level is necessary to determine specific impacted front line communities. This descriptive analysis was derived from the American Community Survey 5-year 2010-2014 Hispanic/Latino Race and Ethnicity (B03002) data set that presents race and ethnicity by defining who is not Hispanic/Latino.

Literature on the United States, California, and Southern California suggests that communities of color, particularly low income communities of color, are also overrepresented in the areas surrounding major freeways, rail lines, and rail yards (Gunier et al., 2003; Boehmer, Foster, Henry, Woghiren-Akinnifesi, & Yip, 2013). In California generally, children of color are three times more likely to live in areas next to freeways and major roads than white children, with Latino children most likely to live in proximity to major goods movement corridors (Gunier et al., 2003). Proximity to major roads is also directly correlated with income level; however disparities across race persist within income groups (Hidden Hazards: A Call to Action for Healthy, Livable Communities, 2010)

With regard to rail yards, the areas surrounding 17 of the 18 major rail yards in California studied by Hricko et. al. in 2014 had significantly higher percentages of people of color in nearby high risk cancer areas than in the surrounding county. Of all races, Latinos were most overrepresented in the areas surrounding rail yards. For 14 rail yards, low income households are also significantly overrepresented in proximate, high risk areas. In Mira Loma, the authors point out, 81% of households close to the rail facility are low income, compared to 34% for surrounding Riverside County (Hricko et al., 2014).

COMMUNITY CONCERNS

The communities surrounding warehouses and distribution centers are concerned about land use changes, loss of community, truck proximity,

and consequences of proximity to warehouse storage facilities. Mira Loma (unincorporated) in Riverside County is a low income Latino community surrounded by warehouses and distribution centers with the highest levels of particulate pollution in the nation (Betancourt & Valianatos, 2012). These children have the slowest lung growth and weakest lung capacity of all children in Southern California (Betancourt & Valianatos, 2012). These residents feel that they are losing their communities to the warehousing boom. There is a fear of losing land that can be used for creating more parks, schools, public buildings, housing, and shops. Community members have complained of trucks using the streets to park and idle as they wait to enter the warehouse. Some have even used the street as a “staging area.” This occurs when warehouses are over capacity and use the streets to fill or empty trucks of their cargo. Residents also feel nervous about sharing roads with trucks that were not designed for heavy vehicles.

ENVIRONMENTAL BURDENS

In California, air pollution exposure is responsible for 19,000 annual premature deaths, 280,000 annual cases of asthma symptoms, 1.9 million annual lost work days, and more than 1 million annual respiratory-related school absences each year (“Hidden Hazards: A Call to Action for Healthy, Livable Communities,” 2010). The South Coast area, comprising LA, Riverside, and parts of San Bernardino and Orange counties, is the

In particular, the highest levels of traffic density were located in areas with warehousing due to the high volume of trucks commuting to load and unload goods.

US EPA, 2014 data analysis

most pollution burdened air basin in the State, and thus the most health burdened (California Air Pollution Control Officers’ Association, 2015).

In the South Coast Area, anywhere between 418 and 1000 people per 1 million will experience cancer due to air toxics. Ninety percent of this health risk is attributable to mobile sources, and 68% is attributable to diesel particulate matter, predominantly from transport, including trucks and trains (South Coast Air Quality Management District, 2014). Impacts are strongly correlated with proximity to transportation corridors including freeway and rail (American Lung Association, 2015). Health impacts of air pollution have galvanized state and federal emission standards to reduce vehicle particulate matter near roadways, but high levels of exposure persist (Wu J, Houston D, Ong P, Lurmann F, & Winer A, 2009).

Figure 3.12: Levels of Diesel and Warehouse Facilities by Census Tract in the Southern California Region

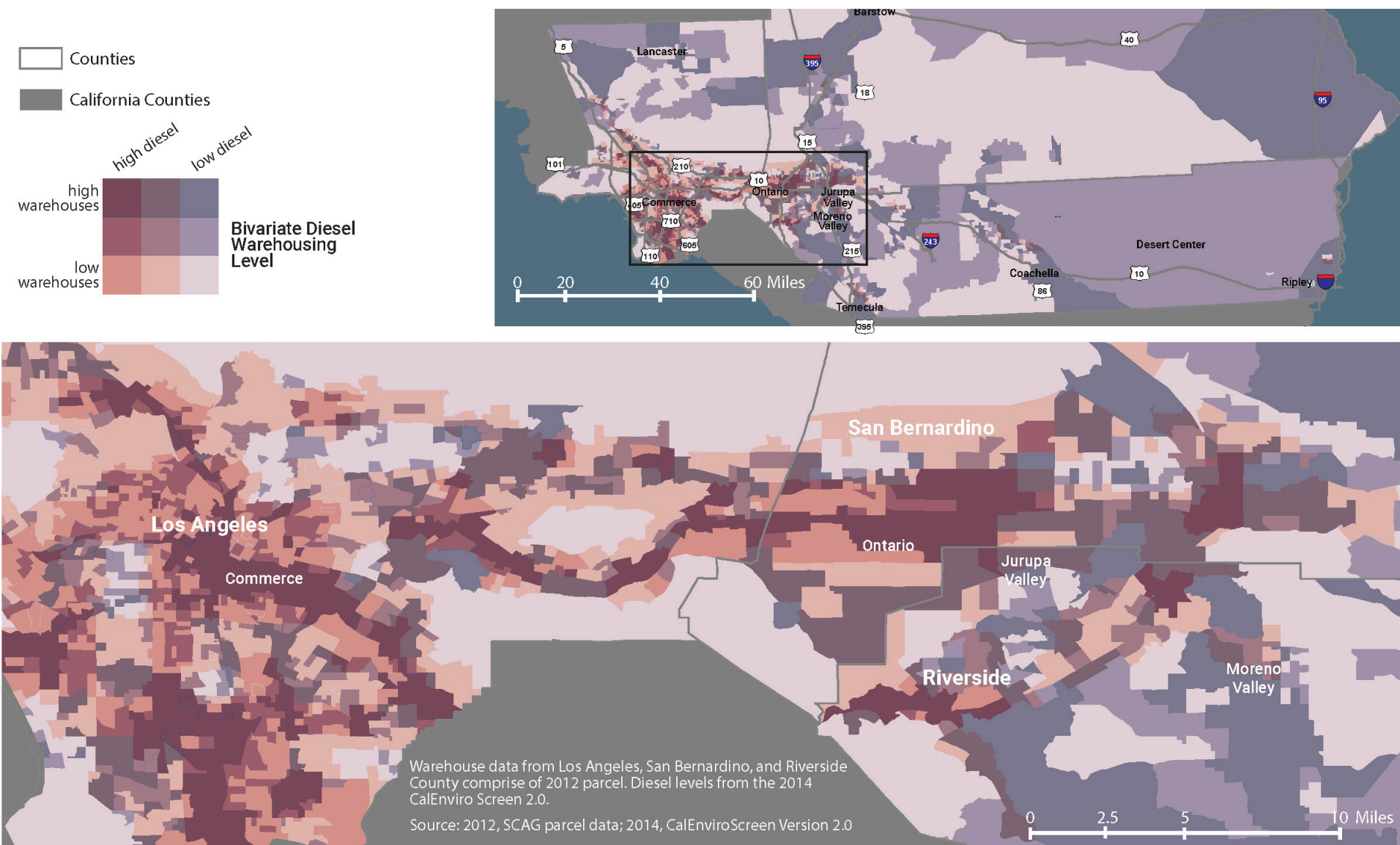

Residents living near high levels of warehousing facilities experience medium to high levels of diesel exposure (US EPA, 2014). In particular, the highest levels of traffic density were located in areas with warehousing due to the high volume of trucks commuting to load and unload goods. To date, the Southern California region does not meet federal ozone and fine particulate air quality standards as mandated by the federal Clean Air Act (SCAG, 2015). The data above, see **Figure 3.12**, was derived from the California Environmental Protection Agency's (CalEPA) CalEnviro Screen 2.0 tool, which identifies disadvantaged communities that are disproportionately burdened by pollution at the Census tract level as of 2014. The tool is used in tandem with the Strategic Growth Council's Affordable Housing Sustainable Communities program that grants cap and trade funding to affordable housing developments. About 36% of the census tracts containing warehouses are eligible for funding from the Strategic Growth Council to reduce high pollution levels in disadvantaged communities.

Similar to areas around warehouses, areas around freeways, rail yards, and railroads are heavily burdened by pollutant exposure and cancer risk. The reason is the same: neighborhoods with warehouses, rail yards, freeways, ports, and rail lines are consistently exposed to diesel and other pollutants emitted by trucks and trains (Hricko et al., 2014). The intermodal yards in the City of Commerce and in San Bernardino stand out as the two most pollution and health burdened communities

in Southern California. BNSF rail yard in San Bernardino, for instance, experience a roughly 150 times greater risk of developing cancer than residents of Southern California generally. These areas are among the most pollution and cancer burdened in the state (South Coast Air Quality Management District, 2015). Traffic-related pollutants are also generally greater near highways and major roads than at ambient monitoring sites in the LA region, leading to high cancer risk relative to other areas in the region (Gunier, Hertz, von Behren, & Reynolds, 2003).

Countless studies have established the link between vehicle combustion, air pollution, and health impacts (Frumkin, Frank, & Jackson, 2004; Zhu, Hinds, Kim, & Sioutas, 2002). Air pollution is a mixture of different kinds of primary and secondary pollutants that have unique signatures in distinct regions. Vehicles cause pollution through primary pollutants released in combustion, and secondary evaporated pollutants (Frumkin et al., 2004). Pollutants from vehicles include carbon monoxide, carbon dioxide, sulfur oxides, nitrogen oxides, ozone and the direct release of these small particles (Frumkin et al., 2004). The smaller the particulate matter, the more dangerous, due to their ability to negatively impact respiratory function, penetrate through lungs and into the bloodstream, and cross the blood-brain barrier.

Pollutants affect residents proximate to transport nodes and networks—particularly around warehouses, highways, rail, and the ports—in four ways: by increasing mortality, threatening

respiratory health, reducing cardiovascular function, and increasing cancer risk (Frumkin et al., 2004). Health symptoms of pollution exposure include having trouble breathing, increased risk of asthma, eye irritation, fatigue, headache, dizziness, and allergic reactions (Dannenberg, Frumkin, & Jackson, 2011; Kim JJ et al., 2004; Matsuoka, Hricko, Gottlieb, & De Lara, 2011). Adults experience having low birth weight newborns, miscarriages, pregnancy complications, in-vitro fertilization failure, breast cancer, cognitive impairment, diabetes, heart and lung disease deaths, atherosclerosis, and chronic obstructive pulmonary disease (Matsuoka et al., 2011). Children have stronger symptoms and overall lung development when raised in proximity to highways (Gauderman et al., 2007).

POLICY AND POLITICAL ENVIRONMENT OF LOGISTICS DEVELOPMENT

Each level of government, from federal to local, holds specific powers to influence inland logistics development in Southern California. “Logistics development” in this section refers specifically to infrastructure projects—highways, rail, and intermodal, real estate projects, warehouse and distribution centers away from seaports. This section broadly describes the authority of government units over logistics development, and (some) key political dynamics shaping governance.

Table 3.8: Governance of Logistics Development in Southern California

Governance	Development Authorities	
	Land Development	Infrastructure Development
Federal	Military Base Land Use Tax Incentives Trade Zone Designation Labor Regulation Trade Agreements	Military Base Land Use Infrastructure Fundings Trade Agreements Industrial Policy
State	Tax Incentives Environmental Regulation Labor Regulation	Funding Streams Environmental Regulation Industrial Policy
County	Regional Land Use Local Land Use Wage Regulation	Transportation Funding
Local	Land Use Planning Wage Regulation	Transportation Funding

GOVERNANCE

The Federal government crafts both national and international policies that continue to shape logistics expansion in Southern California. In recent decades, Washington has exerted considerable influence on development indirectly through trade policy, creating the massive and growing market for cheap imports that drives warehouse development and the need for infrastructure (Bonacich & Wilson, 2011, Crutsinger, 2016). Demand for space will stay strong through the decade with the likely passage of the Trans-Pacific Partnership (Barkham & Darin, 2016).

The federal government also provides 25% of regional infrastructure funding, primarily

raised from fuel taxes (Economic Analysis Branch Division of Transportation Planning California Department of Transportation, 2015). Federal departments grant and lease Southern California lands, including former military bases, which are the present and future sites of massive logistics complexes (i.e. March, Norton, and George Air Bases). Federal tax incentives and foreign trade/custom zone designation add to and multiply Southern California land values (“Foreign-Trade Zones Board,” n.d.). The National Labor Relations Board and Department of Labor play minor parts as labor regulators. The federal government plays arguably no role in writing national industrial policy that involves Southern California (“PERI: The Revival of U.S. Manufacturing,” 2010) **(See Table 3.8).**

California state agencies, law, and the legislature influence logistics expansion in a number of increasingly meaningful ways. The California Environmental Quality Act (CEQA) extends the project development timeline for warehouses and DCs and empowers communities to fight infrastructure plans (e.g. recent SCIG and I-710 rulings) (Benzeevi, 2016). One prominent logistics developer suggests project delays average five years.

Agencies including Caltrans and the California Transportation Commission lead and fund infrastructure projects, mostly highway and rail, through bonds, fees, and general funds, contributing up to a total of 25% of statewide transportation infrastructure funding (Economic Analysis Branch Division, 2015). The legislature also apportions state revenues for various funding programs. The California Labor Commissioner enforces labor rules and punishes employers; the Governor and legislature set the minimum wage standard; and the Governor’s office of Business and Economics Development offers tax incentives to develop warehousing and distribution centers in the southland (“California Competes Tax Credit,” n.d.). In 2015, the Governor reframed state industrial policy via an executive order to develop a statewide Sustainable Freight Action Plan.

Los Angeles, Riverside, and San Bernardino counties retain primary power over land use governance on unincorporated lands, transportation infrastructure development, and sometimes minimum wage policy. In their

“Southern California cities vary drastically in their orientation towards logistics development: some cities actively seek out development, some do not, and some cities will sue their neighbors to prevent truck traffic and other nuisances.

John Husing, 2016

unincorporated areas, counties exclusively dictate land use (Fulton, 1991). Since the retrenchment of federal and state transportation agencies, counties have also become the primary transportation infrastructure funders, through sales tax measures and general funds, accounting for 50% of transportation funding broadly (Economic Analysis Branch Division, 2015). County transportation commissions have become loci of power for infrastructure decisions (Loveridge, 2016). LA County recently emerged as a minimum wage leader and a wage enforcement leader (Los Angeles County Board of Supervisors Pass Fully Funded Wage Enforcement Bureau, n.d.). Whether variation in local minimum wage impacts the location of warehouses is unclear however.

Finally, municipal governments maintain exclusive control over land use and wage rules where there is significant motivation (Loveridge, 2016, Husing, 2016).

KEY POLITICAL DYNAMICS

Within and between levels of government, key political dynamics shape decision making processes around logistics development. Below, six major political trends are discussed in order to clarify how major logistics development decisions are made.

City-Specific Priorities

Local governments, whether counties for unincorporated areas or cities, retain exclusive control over land use decisions. Southern California cities vary drastically in their orientation towards logistics development: some cities actively seek out development, some do not, and some cities will sue their neighbors to prevent truck traffic and other nuisances (Husing, 2016).

At one end of the regional political spectrum are cities like Moreno Valley, Compton, Carson, and the City of Industry--those more or-less captured by industrial development interests (Connell, 2009, Watt, 2015, LA Times Editorial Board, 2015). Records of campaign expenditures and extensive reporting confirm the assertion by former Riverside Mayor Ronald Loveridge that Benzeevi, the major industrial developer in Moreno Valley, “dominates...local politics unlike any other developer that I can identify in comparable cities in California” (Loveridge, 2016, Garrison, 2014).

PRESENTATION BY PENNY NEWMAN ABOUT ENVIRONMENTAL IMPACTS OF WAREHOUSES



Source: Goetz Wolff, site visit

In cities like these, with abundant cheap land, or a predominance of industrial uses, logistics developers exert influence through campaign donations, and through lobbying via regional trade organizations like the Inland Empire Economic Partnership (IEEP), the Distribution Management Association (DMA), or the Valley Group (Bonacich and Wilson, 2008, Garrison, 2014). Through their influence they secure priority land use designations, technically illegal rezoning, and other giveaways (Newman, 2016). Logistics industry boosters, most notably IEEP, have the ear of local policy makers and shape the narrative landscape of development in the Inland Empire region (Allison, 2016).

Voting is a key political variable in small city land use politics that must be noted. Large

populations of young people of color and immigrants who do not or cannot vote in the Inland Empire area concentrate power “in the hands of pro-developer interests” (Betancourt & Vallianatos, 2012). To raise community voice at the ballot box, local groups are organizing phone banks and candidate pipelines (Newman, 2016). An aging electorate will force changes in the municipal land use approaches as young people of color and immigrants age into voting demographics (Betancourt & Vallianatos, 2012).

At the other end of the spectrum of development are cities like Riverside and Rancho Cucamonga, without vacant land, and with plans to intentionally isolate industry in warehousing districts. Rancho Cucamonga recently earned national recognition for sustainability planning (Loveridge, 2016). Riverside recently coordinated parties to sue Moreno Valley for approving the 42 million square foot world logistics center (Husing, 2016).

Lack of Intra-County and Regional Land Use Coordination

Counties play the decisive and exclusive land use role for unincorporated areas. Riverside and San Bernardino counties do not have a solidified regional approach to land use planning for warehousing and distribution centers. Supervisors are known to approve projects without resistance or significant extractions. Unincorporated Mira Loma is seen as an area where lack of county oversight led to a “major mistake” (Loveridge, 2016, Watt, 2015). In Mira

Loma, encouraged by the county, developers built warehouses without regard to proximity to housing and retail functions (Husing, 2016). Now, Mira Loma is seen as the poster child for logistics development gone wrong.

Organized Labor is Weaker Inland Than Near the Coast

Organized labor is much more influential in the political process in the City of Los Angeles, Los Angeles County, and closer to the coast than in Riverside and San Bernardino counties (Allison, 2016, Loveridge, 2016). Similarly, organized labor is significantly more powerful and influential on the Los Angeles County Metro board, and in the day-to-day decisions of political actors in LA County, than in decision making spaces in the Inland Empire. In San Bernardino and Riverside counties, labor groups do not “dominate politics as they do in Los Angeles”, even though there are significant health care and other service work unions in the region (Loveridge, 2016; Wolff, 2016). Local officials in San Bernardino and Riverside are not responsive to these unions at present, only local police and fire unions, which are significantly higher income and whiter than goods movement workers (Loveridge, 2016). In the recent past, the LA County Federation of Labor has considered pushing outside of LA City, into the gateways cities, Riverside, and San Bernardino, to help bolster organizing, which could improve representation for goods movement burdened communities in regional governance (Wolff, 2016).

“The industry perceives that the Southern California Association of Governments (SCAG) is a key conduit for receiving the type of investment the industry desires when and where it needs it.

Inman & Shimoda, 2016

Figure 3.13: Proportion of Projected Infrastructure Funding by Level of Government through 2035 (in Billions)

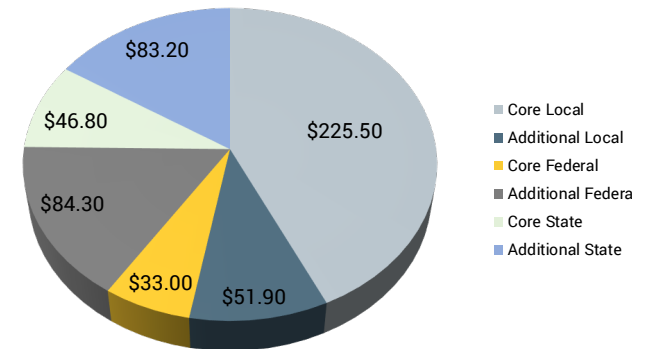

Source: SCAG, 2015

The Industry is Banking on Extensive Public Investment in Infrastructure

Logistics industries across the board rely little on public sector investment except for in the realm of transportation infrastructure (Inman & Shimoda, 2016). In this area, however, the industry is highly active in soliciting investment at all governmental levels in securing port, rail, intermodal, and highway infrastructure. At a recent supply chain summit, top industry representatives, including representatives from the state trucking lobby, Amazon representatives, and UPS identified public infrastructure as the top policy concern for the industry. To this end, the industry perceives that the Southern California Association of Governments (SCAG) is a key conduit for receiving the type of investment the industry desires when and where it needs it. Industry leaders, including California Transportation Commissioners, believe that SCAG's assessments of regional transportation needs drive political decision making at all levels of government (Inman & Shimoda, 2016).

Counties are in the Driver Seat for Infrastructure Development

Counties now provide the major share of funding for regional transportation projects. For large scale transportation projects, 50% of funding comes from counties, largely through local sales taxes; 25% of funding comes from the both state and federal government (**see Figure 3.13**). At the county level, transportation commissions--Metro for LA, SANBAG for San Bernardino, and Riverside Transportation Commission for Riverside--decide the fate of billions of transportation dollars pumped into county coffers through sales taxes. These commissions are filled by local mayors, county supervisors, and other regional political leaders (Loveridge, 2016).

Regional Growth Assumptions and Priorities

The dominant logic among LA region policy makers and administrators is that logistics growth, in terms of shipping, rail, trucking, warehousing, and other services, constitutes an important growth sector for the region. Over and above the pro-logistics boosterism--which holds that logistics jobs currently are good, and the environmental impacts are minimal--decisive policy makers and regional authorities, among them the leaders of SCAG, accept that, even with its faults, logistics is an important sector to foster in the Southern California economy (Loveridge, 2016, Nam, 2016). Few

bodies with administrative control over goods movement planning and infrastructure propose that an alternative economic growth models, or even a degrowth model, can work better for Southern California than largely unregulated goods movement expansion.

STRATEGIC INTERVENTIONS FOR SUSTAINABILITY, EQUITY, AND COMMUNITY POWER

To address the inequalities and injustices of the goods movement system on communities, residents, and the environment, power must be shifted away from corporate interests. The following three interventions systematically address the vested power of special, corporate interests. In addition, these interventions work to give communities and workers the ability to make decisions related to planning, permitting, and funding of goods movement-related activity. These interventions aim to facilitate a just transition to a less-polluting future with good jobs and healthy communities. The interventions focus on ways to leverage the role of the inland port as a starting point for even greater changes throughout the entire supply chain.

ALIGNING EXISTING TOOLS FOR SUCCESS

Existing regulatory tools can align local environmental and labor protections with a just transition framework. Such tools include local city and community level policies such as Green Zones, Community Benefits Agreements (CBAs), and the enforcement of Cal/OSHA policies. These practices are preventative interventions that seek to stop negative environmental impacts by placing restrictions for future development and growth (Hidden Hazards: A Call to Action for Healthy, Livable Communities, 2010). Strong citywide policy implementation and enforcement is essential to prevent negative environmental and labor impacts from harming communities.

EXISTING TOOLS

Green Zones

Green Zones are place-based strategies that use community-led solutions to transform areas overburdened by pollution. The aim is to transform these areas into healthy, thriving neighborhoods via local policies that reduce environmental hazards and promote less-polluting economic activities (Cuajunco & Vanderwarker, 2015). This type of program has been successful in changing zoning designation, and creating stricter development standards in community plans to address the clash of residential and warehousing facilities (“Clean Up Green Up,” n.d., “National City - Green Zone,” n.d.). These standards may require higher-rated air filters in new developments near freeways, and buffer zones between residential and industrial parcels. These designations are created by community and environmental justice organizations by starting a discussion on the need for cleaner air and healthier communities.

Organizations train residents in planning education as they declare their community vision and goals. Some communities represent their vision via a community land use map (“National City - Green Zone,” n.d.). Successes of these zones are determined by their ability to involve the community, gain political approval, create a strong environment and labor coalition, lead community organization advocating, and monitor implementation (“National City - Green Zone,” n.d.; Juarez & Lujan, 2016). The Green Zone program was structured to impact land use policy and therefore can only incentivize

green economic development. It intends to do this by promoting a “Green Economy” that aims to reduce greenhouse gases and create jobs for working class communities and communities of color in buffer zones between heavy industrial and residential areas (Loh & Eng, 2010). The Green Zone program has yet to designate the types of green technology permitted in the buffer and this permits others to define green jobs. Walmart is trying to enter the city of Commerce Green Zone as a buffer. East Yard Communities for Environmental Justice considers this development to go against the policies of the zone due to its increased truck traffic, air pollution exposure, and treatment of workers (Juarez & Lujan, 2016).

Community Benefit Agreements

Community Benefit Agreements (CBAs) are legal contracts made between developers and community organizations that include mandates on the developer to provide certain benefits in exchange for the cooperation or forbearance of community groups. The exact conditions of the agreement vary greatly between cases (Been, 2010). CBAs are particularly useful when a developer needs land use approvals from a local government and the community group has the power to block such approvals (Been, 2010).

All participating parties have something to gain from a CBA. For communities, a CBA may amplify their concerns and demands more than typical land use planning processes. Additionally, CBAs allow communities some control over development specifics not typically

included in land use regulations such as wage minimums, local hiring requirements, and the fair distribution of benefits. The developers receive more supporters for their project, increasing the chances that it will be approved by the local government. For government officials, CBAs allow more benefits to be extracted out of the development than would be possible through normal development conditions. Additionally, CBAs allow politicians to distance themselves from strict development conditions, preventing them from being seen as anti-growth or anti-development. (Been, 2010)

Professor Vicki Been, at New York University School of Law, discusses various categories of when CBAs can and should be used. Been recommends using CBAs only when there is a direct subsidy from the local government for the project. CBAs are a powerful tool for community groups to leverage their abilities to mobilize the masses against a developer to extract benefits; however, due to uneven power dynamics, a lack of transparency, and the difficulty of scalability, CBAs should only be used in truly special circumstances in tandem with broader systematic changes in redevelopment policy.

Cal/OSHA Policies

The California Division of Occupational Safety and Health (Cal/OSHA) is housed under the Department of Industrial Relations and its main purposes are to set and enforce safety and health standards, provide outreach and education around such standards, and issue permits, licenses, certifications, registrations and

approvals that abide by Cal/OSHA standards. In regard to warehouse workers, specifically those temporarily employed, Cal/OSHA is the reason why temporary staffing agencies and host employers are required to work together in ensuring that safety and standards are met. Failure to do so can cause great harm to the employee and be grounds for an investigation.

In 2014, the Occupational Safety and Health Administration (OSHA) along with the National Institute for Occupational Safety and Health (NIOSH) developed a list of recommended best practices to better assist with those communication challenges. This list ranged from recommending that the staffing agency evaluate the host employer's workplace, track injuries and illnesses to help prevent future injuries from occurring, and maintain contact with temporary employees to verify that the host fulfills its responsibilities for a safe workplace (OSHA, NIOSH, 2014).

The National Council for Occupational Safety and Health, the National Staffing Workers Alliance, and the Occupational Health and Safety Section of the American Public Health Association also developed their list of recommendations to ensure that temporary workers, achieve "the full protections afforded under the OSH Act" (NSWA et al., 2013). Similar to OSHA and NIOSH, these recommendations also ask that joint employment structures are clear about their health and safety responsibility. This group also recommends that OSHA track the 20 largest temporary agencies so that compliance

officers can quickly recognize that they are dealing with a major employer. Next, they ask that OSHA strengthens their internal capacity, implement a standard inspection process, and protect workers under Section 11C of the Cal/OSHA Act. Furthermore, improving investigation procedures can motivate workers to complete those procedures to remedy concerns (NSWA, et al., 2013). Cal/OSHA has the intention and power to implement their safety and health standards but need to pay closer attention to temporary workers whom have high risks of injuries and workplace abuse.

High Road Sector Based Economic Development

Creating strategic economic development pathways would increase economic opportunities in the Inland Empire and would help build non-logistics employment opportunities for workers. This would, in turn, reduce the level of surplus labor and reduce the amount of power that warehouse and other supply chain employers have over the labor pool.

The combination of cheap land and a relatively high level of unemployment and underemployment in the area give industry the advantage over workers. High road economic development in the area could provide more jobs and better jobs overall, including in other sectors. This could create or boost potential opportunities to raise labor standards within logistics and warehousing because the supply of workers seeking these jobs would decrease. Some sectors to be considered for potential

“**[An environmental justice] element would require cities to determine the best forms of mitigation and prevention of goods movement environmental health impacts towards populations.**

Leyva, 2016, p. 10

development in the Inland Empire could include solar technologies or manufacturing.

ENVIRONMENTAL JUSTICE ELEMENT

There is a fear among industries in goods movement that implementing environmental improvements equates to loss of jobs. Others fear it would impede port activity or result in widespread automation. The adoption of a state mandated Environmental Justice Element in city general plans will bring additional unity among the clashing environmental and labor organizations. This element can set a precedent for larger cities, such as Los Angeles, to set policies that reduce environmental impacts, further incentivize green jobs, and follow a just transition framework throughout the whole region.

The current Green Zones throughout California require further study and additional support in their early phases. That information can allow advocates to learn how they can navigate through politics, economic development, and implementation. These studies would assist in the creation of future guidelines and methodologies for Environmental Justice Element amendment to Senate Bill 1000. The amendment seeks to require an Environmental Justice element in all California mandated General Plans (Leyva, 2016, p. 10). This element would require cities to conduct impact assessments to reduce health risks in disadvantaged communities through reducing pollution exposure and promoting civil engagement to produce the plan. This reduction can occur by improving air quality, food access, healthier homes, and physical activity (Leyva, 2016, p. 10). This element would require cities to determine the best forms of mitigation and prevention of goods movement environmental health impacts towards populations (including residents, visitors, and workers).

The findings of the element can become a requirement for projects asking for additional financing from the competitive grants of the Greenhouse Gas Reduction Fund (GGRF). This fund contributes to the reduction of emission of greenhouse gases and supports disadvantaged communities. An active bill in the committee process has the opportunity to gather up to \$250 million of the GGRF for a new program called, the Transformative Climate Communities Program (TCCP). This program could be administered by both the California Air Resources Board

and the California Environmental Protection Agency (Burke, 2016). TCCP would continue, “reducing emission of greenhouse gases while demonstrating potential climate, economic, workforce, health, and environmental benefits in disadvantaged communities” (Burke, 2016). Under the new Environmental Justice Element designation, cities would work towards mitigating environmental health impacts of neighboring land uses. Some examples of these uses entail reviewing warehousing facilities, residential homes near freeways, and even potential affordable housing, and proposed “Green Economy” commercial buffers.

The US Department of Labor defines their relation to environmental justice as, “the fair treatment and meaningful involvement of all people, regardless of race, ethnicity, culture, income, or education level, with respect to development, implementation, and enforcement of employment laws, regulations, programs, and policies (“Environmental Justice Strategy - U.S. Department of Labor - OASP -,” n.d.). This is implemented through programs that protect the health, safety, social equity, and security of low-income people of color (U.S. Department of Labor, n.d.). There is a need for this labor expectation to be stronger within the scope of environmental justice with the consideration of how all jobs within the city can become more “green” or sustainable. This is distinct from the “Green Economy” notion of the traditional Green Zone. This new type of “green” -- in addition to the “Green Economy -- policy would consider how jobs throughout the city can reduce emissions,

improve health and support a positive quality of life. For example, this would require new development to adhere to all safety standards with no exception. The element would reinforce rights for temporary workers within the scope of jobs with strong ‘sustainability’ components. Those developments or employers that had lax safety standards due to newer legislation or incentivized development will have to adhere to standards within a certain timeframe. The element would have further motivations for regulating businesses who fail to meet the new standards and work more closely with Cal/ OSHA. The just transition framework would be echoed in promoting affordable housing and a living wage throughout the state.

The required public participation process would highly recommend cities to partner with community based organization to conduct workshops to identify the wants and needs of the population. These workshops can be held at varying parts of the city with various organizations and residents that reside in the area. This can create more focused workshops that consider the environmental impacts of a particular region in Los Angeles to provide sufficient community feedback and data on the varying levels of need and impact throughout the region. At these workshops, residents living near warehousing can discuss the high levels of trucks entering communities, lack of affordable housing in certain parts of the city, and other concerns. Community-based organizations, environmental, and labor groups can direct their campaigns to plan for the element updates

and to have focused issues and/or solutions. Various actors will be involved throughout the development and implementation of the Environmental Justice Element.

POWER ANALYSIS

At the local level for a large city like Los Angeles, there are various actors involved in the development of a city-wide Green Zone. The preliminary power analysis in **Figure 3.14** presents who would support (left) and oppose (right) this intervention and what degree of power (up and down) is influencing the programs implementation. Most influential are city council members that prioritize labor and budgeting, they fall into the neutral category. Labor organizations are less supportive. Both of these actors need to be assured that the Environmental Justice Element would not heavily prioritize jobs over environmental impacts. About six city council members and actors in Decisive Power, Active Participants, and Major Influencers all partially support the element due to their emphasis on environmental justice and the high levels of goods movement networks. There is an opportunity to move actors towards supporting this element.

Figure 3.14: Power Analysis of Environmental Justice Element



PROPOSED GOODS MOVEMENT OVERSIGHT BOARD (GoMOB)

Regional planning for goods movement often does not address workers' rights, environmental justice, or sustainability. Creating a Goods Movement Oversight Board (GoMOB), as a new quasi-judicial state agency with final permitting authority over all goods movement-related developments, would allow for long-range planning and the incorporation of community members and workers at the decision making table.

The proposal for the GoMOB, detailed below, represents an idea for shifting decision making power to communities and workers most directly impacted by the goods movement system. This is a preliminary proposal and would need to be properly vetted by communities and workers themselves prior to implementation. To actualize this proposal, an initial study period should be funded by the state. During this study period, the structure, processes, authority, and funding for the GoMOB should be set forth. The 2016 Sustainable Freight Action Plan represents a good example of the type of study period that would be required.

GoMOB MISSION

The GoMOB would address inequalities and injustices inherent in the goods movement industry in Southern California as it exists today. The GoMOB would engage in long-term community based planning processes to create contextually sensitive guidelines to direct future goods movement related development and infrastructure with the intent of reducing or eliminating diesel exhaust, particulate matter, soot, nitrous oxides, and the many other pollutants tied with the goods movement system in low income communities of color.

Types of projects that would be required to receive a GoMOB permit could include: warehouses, distribution centers, truck terminals, rail facilities, ports, high volume freight corridors (such as freeways and rail tracks), and other potential future transportation modes (including magnetic levitation or Hyperloop-style technologies). The GoMOB would issue final permits for goods

movement-related developments in accordance with relevant regional guidelines and only after rigorous environmental assessment of the project. The GoMOB would take a proactive role as well; acting as a watchdog to ensure safe and fair worker conditions.

GoMOB GOALS

Individuals from communities that are directly impacted by negative externalities and worker organizations would hold two-thirds of the voting seats on the Board. By incorporating these voices into conversations currently dominated by industry groups and politicians, the GoMOB could reduce goods movement-related pollution and public health risks for communities and workers. The GoMOB would have the power to deny permits for projects that it finds would endanger workers, increase pollution burden, or are otherwise inconsistent with the regional guidelines developed by the GoMOB.

The new bureaucracy created by the GoMOB would not only focus attention on approving or denying proposed projects but also on proactively conducting site visits looking to monitor environmental mitigations, working conditions, and worker compensation activities. Through partnering with agencies such as Cal/OSHA and the Department of Labor, the GoMOB would work to improve the conditions of goods movement workers.

GoMOB ADMINISTRATION

The GoMOB would need to be established a State agency to obtain all of the powers needed to control the development of goods

movement related projects. The State would grant this new body final permitting authority over warehouses, distribution centers, truck terminals, rail facilities, ports, high volume freight corridors (such as freeways and rail tracks), and other potential future transportation modes (including magnetic levitation or Hyperloop-style technologies).

While the idea to take final permitting authority from cities and counties and place it with a state-level entity may seem difficult, it has been done in other instances in California. In total, the state has created four regional land use agencies, three of which have, “explicit land use regulatory authority that usurps the power of local governments,” (Fulton, 1991). The California Coastal Commission, the Tahoe Regional Planning Agency, and the San Francisco Bay Conservation and Development Commission are state-enabled agencies which have taken final permitting authority from local jurisdictions in the name of managing development patterns on a regional or statewide scale.

The dual interests of including local community residents and workers as well as planning for infrastructure at a regional scale could result in a multi-level board structure. Sub-regional boards could make primary permitting decisions for sub-regional geographies (i.e. Western Riverside, Gateway Cities). A regional board (covering metropolitan regions or similarly large geographies) would convene to decide on projects of regional significance. The state would be divided into relevant districts to comprehensively monitor goods movement

projects, these decisions could be made in the study period prior to full establishment of the GoMOB.

The GoMOB Board Members would need to represent community and worker voices to ensure that the mission of the organization is being carried out. The sub-regional boards should be made of at least two-thirds representatives from community groups, worker groups, or environmental groups. The other third of sub-regional board positions could represent broader interests such as politicians or businesses to maintain a healthy dialogue between groups.

Regional boards could be made of members from all of the sub-regional boards following a similar ratio that prioritizes community and worker voices. If needed, the multiple regional boards could hold an annual meeting to discuss issues of statewide importance. Assuring that board members represent their respective group of constituents is of the utmost importance. Processes for membership to board (be it through selection by community groups, appointment by elected officials, or special elections) could be determined during the study phase.

The regional and sub-regional boards would issue guidelines delineating the sorts of projects likely to receive a permit. Through these guidelines, the GoMOB could create a far reaching vision for environmental protection and workers rights in areas with concentrated goods movement activities, effectively structuring the decisions of municipalities, public agencies, and developers. Policies could include some of the same recommendations discussed in the other sections of this report.

POWER ANALYSIS OF CREATING A GoMOB

Current power dynamics shape the ability of communities and workers to gain regulatory control over the goods movement sector. The power analysis shown in **Figure 3.15** contextualizes the various actors that could be involved in the creation of the GoMOB in terms of their likely support or opposition on the horizontal axis and their power in making or influencing the decision on the vertical axis. While this is a preliminary power analysis, it shows that lower power groups (including many community and environmental groups) would be in support of the GoMOB. At the upper end

Figure 3.15: Preliminary Power Analysis of the GoMOB

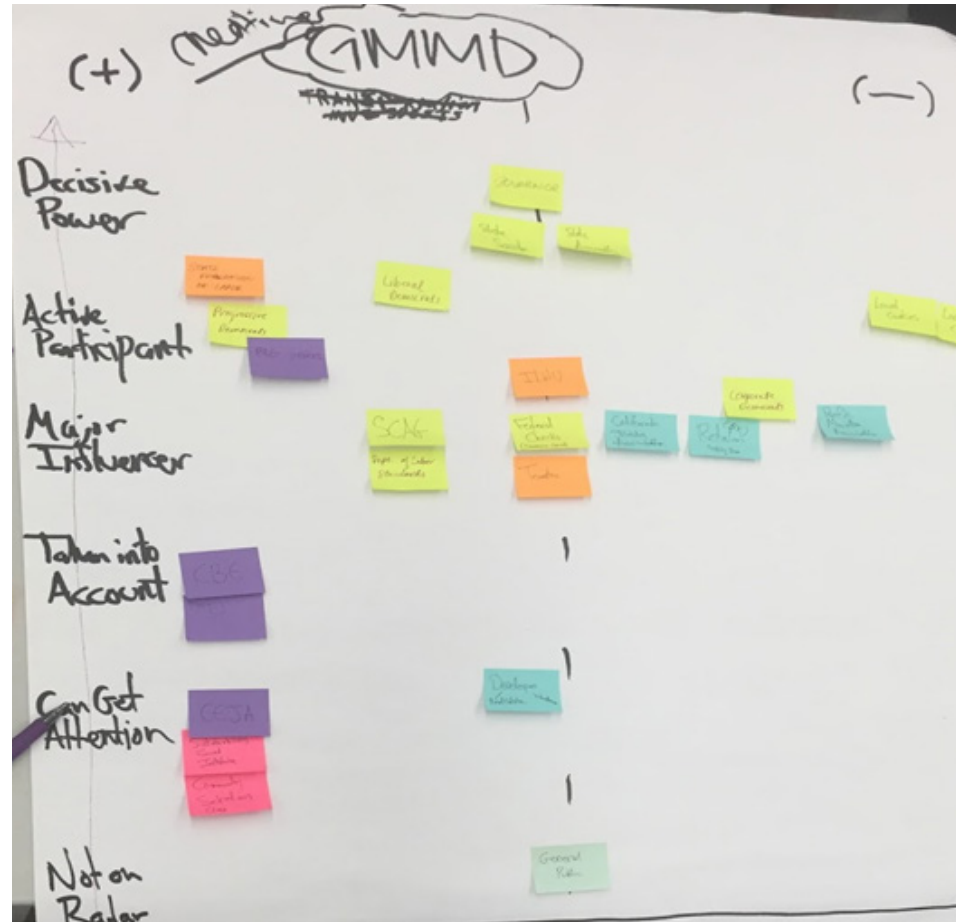

of the power ladder, groups can be found both in support and in opposition. Supporting groups could include: progressive democrats, big green groups (i.e. Sierra Club), and government planning and labor organizations (i.e. SCAG and the Department of Labor). Powerful opponents could include: cities and counties, business groups, and conservatives. Major actors that still remain neutral and could be moved towards supporting the plan include: the governor and organized labor.

Supply Chain Equity Alliance: A Community and Labor Coalition

Moving organized labor to support the GoMOB and moving community groups up the power ladder could be achieved through the creation of a community-labor coalition focused on goods movement. This proposed coalition, a Supply Chain Equity Alliance, could work to enforce worker rights, health, and safety while increasing benefits and compensation. Simultaneously, this Alliance could work to end pollution and other externalities faced by communities. The Supply Chain Equity Alliance would be focused on realizing the vision of a just transition in the goods movement sector. Gathering support around the creation of the GoMOB could be this Alliance's first action--setting precedence for historic community and worker benefits going forward.

TRANSPORTATION INFRASTRUCTURE INTERVENTIONS

Industry recognizes the centrality of public infrastructure to maintaining its bottom line. Without good roads, the goods move slower, and they cost supply chain owners more money to move. For this reason, executives believe that corporate stakeholders in the supply chain should make lobbying for infrastructure investment an absolute top priority (Inman & Shimoda, 2016). Industry executives from industrial real estate and transportation sectors

donate large sums of money to legislators and sit on critical boards for project development and financing, including the California Transportation Commission board, and boards of influential academic transportation research centers (METRANS Transportation Center, n.d.).

Community, labor, and citizen groups have struggled to articulate their power over infrastructure planning. When not discriminated against, racialized, and exploited, communities lack an empowered seat at the table (Diaz, 2005, Gotham, 2002). Some communities and labor actors have become exceptionally powerful in infrastructure planning, however, finding their leverage through organizing and litigation (though for some wealthy communities through money). Notably longshore unions (ILWU), environmental justice groups (including EYCEJ and CBE), and community, labor, environmental alliances (the Coalition for Clean and Safe Ports) have been recent influencers in the world of Southern California infrastructure governance (Bonacich & Wilson, 2011).

Below, two broad sets of interventions are suggested so that community and labor groups building power in the supply chain and affected communities might redirect investment priorities to advance sustainability, social equity, and community power goals. Proposed interventions fall into the broad categories of extractions from industry, and investment realignment strategies.

EXTRACTIONS FROM INDUSTRY

One way to alter the balance of power between communities and business in infrastructure development is to raise the cost on industry for polluting burdened communities. Balancing the costs to communities by taxing BCOs or other entities, may result in forwarding those benefits to these communities. At present, logistics businesses are taxed on heavy duty vehicle purchases, tires, and fuel, but the proceeds are not allocated proportionately by community impacted when considering the benefits to logistics--since most of these taxes are levied by the federal government.

An example of unbalanced costs can be found when comparing the external costs of goods movement by truck and by rail. Within the shipping industry, shipping by truck has greater subsidies compared to rail because of its greater use of public infrastructure (Austin, 2015). This is because trucking companies use routes that rely completely on public roads and highways, while freight trains utilize public right of ways only at grade crossings. Since roads and highways are maintained with public funds, and most railroad infrastructure is privately maintained, there is an imbalance of public funding beings used for the two modes. When including other external costs such as traffic congestion, traffic safety, and emissions, the cost of shipping by truck is 15.6 cents per ton-mile versus 5.1 cents per ton-mile by rail (Austin, 2015). However, instead of trying

to increase funding for rail, the fees associated with freight trucks should be increased. There are a number of policies under consideration that might offer opportunities to equalize costs and benefits for local communities:

- **Increase current excise taxes:** An increase in the current diesel and tire tax would extract greater revenue to offset current external costs of moving goods. An increase in diesel taxes will motivate shippers to use more fuel-efficient trucks that would also reduce polluting emissions. A greater tire tax will penalize and decentivize moving heavy loads which damages roads the most.
- **Impose a variable charge based on weight and distance:** Presented by David Austin, another way for jurisdictions to be compensated by external costs from trucking is by charging trucks by the weight of containers and distance travelled (Austin, 2015). The revenue can then be reinvested back to both the road maintenance costs and the local communities that suffer from the effects of high truck traffic.
- **Implement user-based fees for freight-only public facilities:** User-based fees such as tolling can be implemented on commercial drivers that use lanes and highways that were specifically created for freight vehicles. These include truck climbing lanes and freight-only highway corridors. These fees can help finance the

facility's construction instead of solely public funds, and future tolls revenues can be earmarked for use by the adjacent, impacted communities.

The existing and suggested additional funding sources can then be earmarked for programming for communities impacted by these facilities. This would be a model of participatory budgeting that has been implemented in certain areas around the country (PBP, n.d.). Community members would be able to suggest, vote on, and implement projects and programs using the allocated funding. Some examples of projects are community gardens in Vallejo, CA, bike lanes in Chicago, IL, and recreational parks in Boston, MA.

REALIGNMENT OF FUNDS

Another way to improve infrastructure finance is to realign public sector priorities. Public priorities should be realigned in two broad ways: (1) to offer reparations for past harms; and (2) to subsidize alternative infrastructure and economic development priorities.

Reparations-type interventions

These interventions should aim to both stop potential harms of new projects, and alleviate hardships incurred in the past, in ways that communities desire for the future. Such a form of meaningful compensation directed by communities reflects aforementioned definitions of social equity and community power. The logic of this intervention rests on the fact that most upcoming transportation projects envisioned

by the California Transportation Commission, regional transportation commissions, and SCAG intend to expand or make existing freight corridors more efficient through freeway widening, truck climbing lanes, or rail enhancements. These investments should be reconfigured in such a way as to both diminish current pollution burdens and to counteract effects of the pre-existing infrastructure.

Infrastructure funding might be realigned to require the following sorts of reparatory investment in communities along with infrastructure upgrade, if it is to occur:

- **Local Environmental Mitigation examples:** air filters in homes and buildings within 1000 feet of the highway, rail line, port, or intermodal yard; buffer trees along movement corridors; free transport to enable movement across highways and rail lines that divide communities; relocation of sensitive receptors such as schools away from infrastructure (Wachs, 2016).
- **Local Economic Development examples:** local hiring, workforce training, and pipelining for public sector, unionized construction careers; priority hiring of low income, people of color, women, LGBTQ+, formerly incarcerated, and undocumented people; ensuring non-replacement of any infrastructure-related work with parole or probation labor or community service (Zatz, 2016).

→ **Local Sourcing examples:** prioritize local sourcing (and workforce development outlined above) of all construction materials including demolition, printing, concrete, etc (Wachs, 2016). Investments should incubate worker-owned cooperatives that source sustainably.

Any of these reparation policies should guarantee a majority stake at the decision making table for community representatives. A proposed structure of community participation will not be elaborated here, but would have to evolve out of an organizing process, and perhaps come to a similar outcome as the proposed GoMOB above.

Alternative Investment-type Interventions

These interventions should aim to broadly shift the goals of transportation investment away from subsidizing goods movement, increased traffic, pollution, and environmental harm, and towards improving connectivity of isolated neighborhoods, building new transit, improving existing transit, and incubating sustainable, worker owned industries with the capacity to sustain regenerative economies.

Regional transportation entities with the capacity to greatly realign their funding priorities should transition towards spending significantly more of their discretionary budget on transit improvements in isolated neighborhoods. The San Bernardino spending plan for Measure I funds allocates only 18% of funds towards public

transit (SANBAG, 2014). While Metro proposes to allocate approximately 65% of its sales tax dollars to transit, the agency has famously neglected to prioritize transit for underserved areas (Metro, 2012, "From Bus Riders Union to Bus Rapid Transit," 2015).

As a way to both promote regional connectivity and transition regions towards a sustainable and equitable development model, counties, if not state and federal agencies, should realign spending priorities. Agencies should create rotating zero interest loan funds that incubate local worker owned coops producing transportation-related goods and services. This visionary strategy advanced by the Southern Grassroots Economy Project, and others, entails offering loans to "cooperatively owned enterprises that benefit the community so that they can develop" (Coronel et al., 2016).

Money from successful projects could then be recirculated into the loan fund to incubate other cooperatives, creating a non-extractive financial model that sustainably develops communities (Coronel et al., 2016). The promise of such a fund for transportation-related coops is both very different from our current status quo, but proven to work in civil society, notably in Spain's Mondragon community of cooperatives, and in the Evergreen Cooperative in Cleveland (MONDRAGON Corporation," n.d.; "Evergreen Cooperatives," n.d.).

CONCLUSION TO THE INLAND PORT



There needs to be a shift in power from corporate influence over logistics related development to worker and community control. There has been consistent growth of warehousing facilities and infrastructure development without any regional oversight.

This has created a haphazard development pattern which has resulted in concentrated negative environmental impacts, especially on communities of color. Appropriate interventions to address the negative externalities experienced by the front line communities should always incorporate voices from impacted residents and workers into government policies and regulations.



4

TRANSPORTATION TECHNOLOGY

MIGUEL BARRITA, KATE BRIDGES, GABRIEL GUTIERREZ, SALY HENG, EVAN MOORMAN, & ARIANA VITO

TRANSPORTATION TECHNOLOGIES

Strategic Interventions for Social Equity, Sustainability, & Community Power

1

TERMINAL OPERATOR FINES

The Ports should fine terminal operators for long total turn-times and give this money back to waiting truckers and the local residential community which suffers from poor air quality caused by excessive idling. The community should define how the funding should be used within certain parameters. The data needed to implement this program will come from GPS sensors that the Ports could mandate for all trucks serving the Ports.

2

FLEXIBLE PIERPASS PROGRAM

The Ports should encourage a more flexible PierPass program in which the GPS sensors on trucks allows for the collection of “big data” on truck movements. This would allow for more demand-based and flexible pricing schemes, which would improve efficiency at the Ports.

3

FREE-FLOW CONTAINER SYSTEM



The Ports should continue to encourage free-flow container systems. Such systems boost productivity dramatically, but their utilization can necessitate the creation of large container yards for transloading in nearby communities. Thus, the Ports should mandate a per TEU fee on each container and reinvest some of that money back into the community on environmental projects that can mitigate the increased truck trips in the area.

4

GREEN JOB TRAINING FOR DISPLACED WORKERS & IMPACTED COMMUNITIES

Prioritize green jobs for displaced workers and impacted communities. The SEED Program, a HUD-affiliated program to increase STEM engagement among low-resourced communities, should also be expanded.

INTERVENTIONS KEY



-  Social Equity
-  Sustainability
-  Community Power

TRANSPORTATION TECHNOLOGIES CONTINUED

Strategic Interventions for Social Equity, Sustainability, & Community Power



5 CAREER PATHWAYS IN SUSTAINABLE INDUSTRIES   
Leverage public workforce development funds with public-private partnerships to create more career pathways in sustainable industries.

6 COMMUNITY BENEFITS AGREEMENTS  
Regional transportation agencies, including SCAG and Metro, and/or state agencies, including Caltrans, should negotiate Community Benefits Agreements as part of regional truck-tollways like the proposed Clean Freight Corridor.

7 COMMUNITY & TRUCKER INCLUSION WITHIN JPA  
Ensure the inclusion of community groups and truck driver representatives on the Joint Powers Authority (JPA) that implements the regional network of truck tollways, especially considering the anticipated public subsidy involved with the project.

8 CLEAN TRUCKS 2.0  
Clean Trucks 2.0: Implement incentives and mandates to replace the current fleet of heavy duty diesel trucks with .02 natural gas engines fueled by renewable natural gas. Ensure that the financial burden does not fall on misclassified truck drivers.

INTERVENTIONS KEY

-  Social Equity
-  Sustainability
-  Community Power

CHAPTER 4: TRANSPORTATION TECHNOLOGY

INTRO TO TRANSPORTATION TECHNOLOGY

TECHNOLOGY DRIVES EFFICIENCY, BUT DOES IT GUARANTEE SUSTAINABILITY, EQUITY, AND COMMUNITY EMPOWERMENT?

Technology is a major driver of efficiency improvements intended to increase overall productivity at the Ports, as well as regional competitiveness and economic growth in the Southern California region. These innovations affect local and regional infrastructure, air quality, job opportunities, land use, public spending, and much more. In this chapter, we analyze key innovations in transportation technology for goods movement under the lenses of social equity, sustainability, and community power. These include appointment systems, port automation, zero emission or near zero emission trucks, truck-only toll ways, and truck automation.

These five transportation technologies were selected based on a) their potential to impact sustainability, social equity and community power outcomes; and b) their relationship to current systems or planning activities by the Ports and other regional transportation agencies. By no means do these five innovations encompass all of the work underway in the public and private spheres to advance goods movement. The Ports continue to invest planning efforts in the expansion of on-dock and short-haul rail as a way to speed cargo throughput and reduce truck trips. In the private sector, Hyperloop technology has emerged, in very early stages of development, as a fast and emissions-free freight option. There will certainly be many more innovations to come; such is the nature of technological change. Given the limited timeframe of the Community Scholars project, we narrowed our scope to these five technologies to explore how they intersect with environmental goals, labor organizing, and community activism.

HIGHLIGHTED TECHNOLOGIES

Technology-driven improvements in productivity may benefit business and consumers, but do not always lead to more sustainable, equitable, or empowered community outcomes, particularly with respect to goods movement.

APPOINTMENT SYSTEMS

Appointment systems offer the ability to schedule pick-ups ahead of time at the Ports and coordinate truck driver arrivals with the offloading of their respective shipments, thereby mitigating congestion and speeding turn-around times. Terminal operators at the Ports each implemented their own appointment systems in response to a state mandate in 2003. These actions have produced mixed results. Truck drivers report long waiting periods for their shipments and difficulty meeting appointment times due to congestion delays on freeways. Evolution towards a uniform port-wide system, characterized by better collaboration, data sharing, and competition among private firms, could lead terminal operators to improve turnaround times for truck drivers. More work is needed, however, to ensure port truckers are given a voice at the table. The implementation of fines for both truckers and terminal operators, use of big data to make the program more responsive, and exploration of free-flow cargo systems could prove beneficial under the right policy framework.

PORT AUTOMATION

Port automation, like that seen at the TraPac and Middle Harbor terminals, can increase cargo-movement efficiency, improve worker safety, and reduce air pollution, resulting in overall gains in productivity and competitiveness in the SCAG region. Port automation is also expected to increase terminal capacity, which may lead to growth in

the logistics industry, but may also magnify negative externalities. Port automation is part of a larger trend of automation technology that is likely to impact the warehousing and trucking sector. These advances are expected to result in the displacement of entry-level employment in off-dock occupations. Jobs created in the automated workplace will also require a more comprehensive set of skills, which could create barriers to entry for individuals and communities with low levels of adult education.

CLEAN TRUCKS

Clean trucks reduce harmful emissions, which impact surrounding communities. The poor air quality near the Ports is largely due to emissions from the approximately 14,500 heavy-duty drayage trucks servicing the region each day. Transitioning to cleaner fuels is essential to reduce emissions and improve living and working conditions. The previous Clean Trucks Program, which implemented a mandatory phase-out of old, dirty trucks by 2012 successfully reduced ozone and particulates, but port activity since then has risen substantially. There is a debate surrounding which fuels and technologies are the best solution to the problem, with significant political and financial support leaning towards electric trucks. Research shows that there are more feasible solutions, including the use of renewable natural gas with natural gas engines.

TRUCK-ONLY TOLL (TOT) LANES

Truck-only toll ways have been proposed by local agencies to address congestion on the I-710 and SR-60 freeways serving the Ports and related logistics hubs. The plans involve

dedicated truck-only facilities and tolls levied on a per-mile basis. The proposal would potentially increase freight capacity, reduce collisions, encourage the adoption of cleaner trucks, and manage demand for limited roadway space. The pervasive Independent Owner Operator model, however, poses a serious problem for this plan. Tolls may be cost prohibitive and therefore limit demand among truck drivers serving the ports. Moreover, a regional truck-only toll network will require substantial public subsidy, therefore toll revenue should be reinvested in communities most severely affected by freight corridors.

TRUCK AUTOMATION

Truck automation is being developed in stages, in accordance with federal guidelines, over the next ten years. Fully-automated trucks may address a growing driver shortage and allow for other time and emissions savings innovations such as truck platoons. However, automation technology, as seen in on-dock activities at the ports, will likely affect job access and quality for off-dock workers. Employers have a major incentive to migrate towards complete automation given that driver labor costs constitute approximately 30 percent of total operating expenses. Overall trucking jobs are expected to decrease, although there is potential for new jobs to be higher-skilled and higher quality.

HOW THESE TECHNOLOGIES WORK TOGETHER

Many advantages of these technologies depend on their working together in concert.

Gains in efficiencies will be most realized if the appointment system, automated terminals and tolling systems are coordinated so that cargo is ready for pickup at the appropriate time. Dedicated truck facilities, in cooperation with automated vehicles, may allow other innovations, such as truck platoons, which further increase speed while reducing emissions. And cleaner vehicles throughout the system will be the only way to dramatically reduce harmful emissions. Worker conditions, often neglected by new technology proponents, underlie the success of all these technological changes. Without proper intervention, the introduction of cleaner trucks, automated equipment, and tolling lanes will result in job losses and financial burdens on the people who move the cargo from port to distribution center to market.

ENVISIONING SUSTAINABILITY, EQUITY AND COMMUNITY POWER

Advancements in technology alone will not solve our economic or environmental problems, particularly as efficiency improvements increase the capacity of goods movement handled at the Ports. Enhancing efficiency at the cost of labor, the environment, and the broader economic needs of surrounding communities is counter-productive. The goods movement system in Southern California requires a holistic approach that balances policy interventions with technological innovation to foster sustainability, social equity, and community empowerment.

TERMINAL APPOINTMENT SYSTEMS

BACKGROUND & CONTEXT OF THE PORT TRUCKING SECTOR

Port trucking comprises a crucial part of the LA County economy as well as an important part of the global logistics chain. Simply put, port trucking allows transloading from massive cargo ships that dock at the Ports to the rail yards that lay east and south of Downtown Los Angeles, or to the massive warehouses in western Riverside and San Bernardino Counties. Port trucking (or drayage) employs anywhere from 12,000 to 16,000 people (Hall, 2008; Bensman, 2009)—heavily concentrated in the employment-scarce and low-income sections of southern LA County (it is important to note that this figure is subject to various estimates and doubtlessly shrunk following the Great Recession).

As of 2009, an estimated 20 percent of nationwide port truck drivers were based in Los Angeles, Riverside, or San Bernardino Counties (Bensman, 2009). Truck drivers reported an average gross income in 2009 of approximately \$28,000 (Bensman, 2009), thus, the amount of money coming into the households of Southern California truck drivers is nearly \$500 million annually. While such figures may seem impressive on paper and in isolation, the industry has become increasingly competitive

over the past decades. Despite tremendous gains in “industry efficiency”, truck drivers suffer depressed wages, longer work hours, and fewer benefits. These problems, largely the result of legislative and policy changes over the last three decades, will be discussed below.

HISTORY OF THE PORT TRUCKING SECTOR

Before 1980, the general trucking industry was highly regulated; trucking companies were limited by the Interstate Commerce Commission in the routes upon which they could operate; this included routes surrounding the ports, even though such routes are arguably more international than interstate in nature. Prices were also highly regulated in a manner similar to the airline industry. The International Brotherhood of Teamsters organized the LA port truckers; the terms for union entry helped to limit the number of trucks - and drivers- that could operate at the ports (Bensman, 2009). As key proponents of deregulation and responsive markets like Margaret Thatcher and Ronald Reagan rose to power, these concepts began to shape policy making in the trucking and other sectors.

THE RISE OF DEREGULATION IN PORT TRUCKING

In 1980, President Carter, with the assistance by Senator Ted Kennedy and consumer-advocate Ralph Nader, passed the Motor Carrier Act, which deregulated the trucking industry (Bensman, 2009). This deregulation allowed new firms to enter into the market, which increased the supply of the market and

decreased the price that truckers could receive. Non-union firms entered the market, underbid, and forced out the unionized “shops” (Bensman, 2009). Some firms started using a diffuse and “capital-lite” business model that essentially relied upon truckers that would work for the company, but remain “independent” workers/non-employees; the workers could often make more money up-front, but would be responsible for almost all costs related to the job, including the purchasing of the vehicle. By 2004, such workers—called independent owner-operators (or IOOs) comprised roughly 87 percent of the national port trucking workforce, with a similar percentage shown in the Southern California market (Monaco, 2015).

CURRENT STATUS OF INDEPENDENT OWNER OPERATORS

As a result of such reforms, income for truck drivers declined significantly in relative terms, according to Hall (2008), who studied the income of transportation related jobs from 1976-2006 through the Current Population Survey (CPS). However, the seemingly modest decline in 2006 dollars from \$38,000 in 1976 to \$34,000 in 2006 understates the true decline because this figure does not consider the fact that after deregulation, truckers were usually compelled to pay for their own truck, fuel, tolls, and insurance (Monaco & Grobar, 2005). IOOs also began receiving payments by the load-carried, and not by the hour. This arrangement has profound implications for how truckers make their money (it also renders inefficiencies within the Ports a social equity issue).

The Monaco (2005) study—in which some 175 truck drivers were interviewed—determined that the average take-home pay was some 25 percent lower after such costs were subtracted, and was equivalent to an annual amount of \$29,000 (equivalent to some \$35,000 once adjusted for inflation) (“CPI Inflation Calculator,” 2016). While such a figure might seem to almost allow an entry into the middle-class, this figure must be balanced with the fact that such truckers overwhelmingly work without benefits and that the median number of hours worked/day is 10 (50 hours/week) (Monaco & Grobar, 2005). This means that the average 100 truck driver is barely earning about the \$10/hour state minimum wage (and will likely earn far less than could be earned through a \$15 minimum wage job in the future).

Because IOOs are not technically employees, they do not have to be paid an hourly wage (just as any business owner would not pay him/herself a wage). This creates a problem at the Ports, however, where long waiting times are not generally compensated (Anonymous Interview of Port Trucker, 2016). If truckers are compensated, it is usually only when a trucker has waited over two hours, after which they will get paid (Anonymous Interview of Port Trucker, 2016). Congestion along the 710 Freeway and the 210 and 10 Freeways going east to the Inland Empire is among the worst in the state (“The 10 most congested freeways in California,” 2014) and travel times are unreliable; therefore, travel times even outside the Ports can be long. However, for port truck drivers, perhaps the

biggest problem is the congestion in the terminal areas, where port truckers often must wait for hours to pick up their load. In 2005, interviews found that waiting times comprised between 50-66 percent of all time spent on the job (the interviewers asked truck drivers to recall their last job, and so while accuracy was not perfect, it was presumably sufficient) (Monaco & Grobar, 2005).

SOCIAL EQUITY ISSUES OF THE INDEPENDENT OWNER OPERATORS

The disproportionate percentage of time that truckers spend waiting for their loads at and within the terminal gates exacerbates social equity issues for the IOOs. As mentioned above, very few truck drivers are paid by the hour and so waiting for hours at the terminals directly erodes paychecks. Standard economic theory holds that low pay would cause some truckers to exit the market—boosting pay for the remaining workers—but this assumes a certain amount of market power that may not exist among the truckers because of their status. Monaco and Grobar (2005) reported that 93 percent of truck drivers surveyed in 2004 were male Hispanics, only half of which claimed to be legal citizens of the county, a figure that is likely inflated.

There is some evidence that the percentage of undocumented workers has fallen after 9-11 as a result of concerns over the security of the ports (Monaco & Grobar, 2005). In any case, as seen in **Figure 4.1**, educational attainment among the Southland port truckers is low and language skills among some drivers is also low

Figure 4.1:
Education Level of Port Truckers

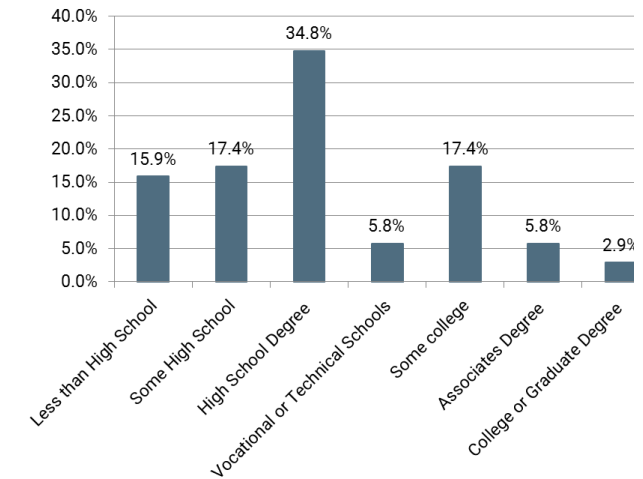

Source: Monaco & Grobar, 2005.

(Monaco & Grobar, 2005). Therefore, one should not assume that port truckers could easily leave for other opportunities in the region in response to declining wages from long waits.

Therefore, one should not assume that port truckers could easily leave for other opportunities in the region in response to declining wages from long waits.

Secondly, trucking firm owners have little to no incentive to push for efficiency improvements in the system either within their own trucking companies or within the port appointments system (Gibson, 2011). After all, why would a trucking company owner push for advanced scheduling software—or even invest in supporting human

resources to improve the efficiency of the appointment system from the business end—if they are not paying hourly wages? It stands to reason that the trucking companies would hire more IOOs to increase the effective supply of labor that can actually transport goods at any one time, but they wouldn't necessarily pay more overall because of the high amount of congestion surrounding the ports. Thus, congestion at and within the terminal gates has not yet led to either an organic “market response” of higher wages or pressure from the business community to improve congestion at the terminal gates.

One group that does have a large economic incentive to improve efficiency at and within the terminals is the group of terminal operators themselves. The terminals are run by private companies—or sometimes by complex consortiums—for whom competition for goods is pivotal; indeed, such competition lies at the root of efficiency gains, including recent automation strategies at different ports around the world (De Langen and Pallis, 2006). Nevertheless, incentives to invest in output can be somewhat eroded by the very high labor costs of the dockworkers, who are organized by one of the more powerful unions in the United States, the ILWU. Greater productivity can require more workers at certain times or the extension of hours, both of which can be quite expensive (Giuliano & O'Brien, 2007). After all, every dockworker costs approximately \$1,000 per day (Giuliano, O'Brien, Hayden, & Dell'aquila, 2006). Furthermore, in ports that occupy a strategic point in the global logistics system—such as POLA and POLB—theoretically fewer incentives

exist to maximize productivity to attract more cargo.

Shippers also have large economic incentives to improve efficiency within the logistics system. Over the past few years, the shipping industry has experienced significant consolidation, moving more containers in fewer trips via megaships. The corollary to this is that the strategic ports of the world trading system have come under increased pressure. Just-in-time delivery systems have also played a role in building pressure on the logistics system. If land-based trucking systems face an unreliable and difficult experience at the terminals, shippers can experience financial losses, especially among certain perishable items.

ENVIRONMENTAL ISSUES CAUSED BY PORT TRUCKING

Despite the conditions of the port truckers and competition with other North American ports, (“Economic Impact and Competitiveness of the West Coast Ports and Factors that Could Threaten Growth,” 2014), the decisive reason for the implementation of the current gate appointment systems stems largely from concerns about environmental degradation in the LA Basin, particularly for the low-income, communities of color near the Ports who suffer the County's worst air pollution. While environmental concerns of smog have been issues on the public radar for many years, and have shaped progressive agendas in Southern California since the 1970s, issues of environmental air pollution and degradation reached a fever pitch in this community in the

early 2000s as imports surged (the result of the Chinese economy reaching 10 percent annual growth levels, and a weak U.S. dollar as seen in **Figure 4.2**). The issue caught the attention of State Assemblyman Alan Lowenthal.

THE FIRST APPOINTMENT SYSTEMS

This section will discuss the first appointment systems and the response of relevant parties to this change. This section—while covering an event that occurred over a decade ago—will provide clues as to the problems that must be overcome to implement a successful appointment system. These lessons will inform predictions and recommendations going forward.

AB 2605 - THE LOWENTHAL BILL AND THE FIRST AMENDMENT SYSTEM

In response to public concerns, State Assemblyman Alan Lowenthal introduced a bill in the CA legislature in 2002 (passed in 2003) that sought to decrease ambient air pollution in the vicinity of the Ports port by instituting an appointment system. Lowenthal thought a formal appointment system would decrease waiting times in the lines leading into the terminals, which would in turn decrease pollution caused by idling trucks. The legislation “fined terminal operators \$250 for each truck idling more than 30 minutes while waiting to enter the terminal gate” (Giuliano & O'Brien, 2007, p. 462). However, the fine could be avoided if the terminal operators did one of two things:

Figure 4.2: Cargo Levels at the West Coast Ports

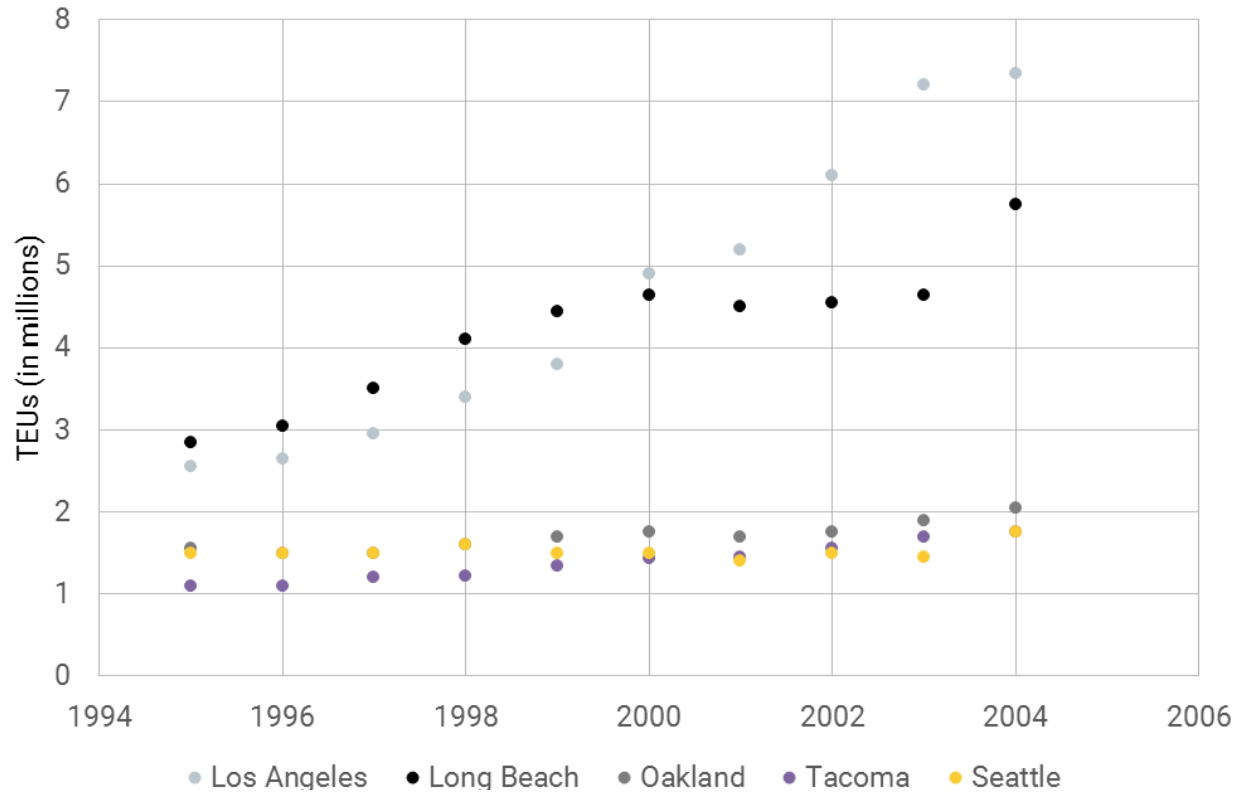

Source: Giuliano & O'Brien, 2007.

1. Extend the time that gates were open to 70 hours per week by increasing the number of weekend or evening hours.

2. Create an appointment system for trucks so that demand could be anticipated and spread out (Giuliano & O'Brien, 2007). However, simply creating an appointment system would not

guarantee avoiding the fine. If a trucker did make an appointment and they did not get into the terminal within 30 minutes, then—and only then—would a fine be imposed on the terminal. If the terminal operator offered an appointment system and the trucker in question did not schedule an appointment, then he/she could wait indefinitely without a fine.

In retrospect, the bill was flawed because it only regulated waiting times outside of the terminal gates; it did nothing to curb long wait periods for containers once inside the terminal. Indeed, anonymous interviews with truck drivers confirmed that some 14 years after the introduction of the so-called Lowenthal System, in-terminal wait times remain significantly elevated, in their view because of understaffing on the docks (Anonymous Interview with Port Truck Drivers, 2016).

The original bill was also flawed because it only referred to trucks that were idling and not trucks that had turned off engines (Giuliano and O'Brien, 2007). The bill—as mentioned earlier—was based more on environmental concerns than concerns about the livelihood of IOOs. A new bill—based on the original one, but no longer exempting non-idling trucks—was passed in 2004. How did the terminal react to the Lowenthal Bill? Freight experts describe how 13 different terminal operators took action (Figure 4.3):

“Of the 13 different terminals then in operation at the San Pedro Bay Ports, “seven terminals adopted an appointment system, two added appointments to pre-existing but limited extended gate hours, three had pre-existing fully compliant extended gate hours, and one elected to do neither (hence making all trucks subject to the 30 min queuing limit). That is, no terminal chose to comply with AB 2650 by instituting extended gate hours, or even modifying existing extended hours” (Giuliano & O'Brien 2007, p. 464).

Figure 4.3: Responses of Terminal Operations to the Lowenthal Bill

Terminal	Compliance method	Extended hours	Appt system provider	Same day appts?	Phone appts?	Gate procedures
WBCT	Appointments	Saturday, Sunday - limited hrs	MTC Voyager	Yes	Yes	No priority
Yusen	Appointments	Day shift 7 days/week	Navis (no fee)	Yes, to 3:30 PM	Yes	3 appt lanes; all 9 at AM opening
APL	70 h gate operation	Yes, for specific moves, shipping lines	N/A	N/A	N/A	N/A
APM Maersk	70 h gate operation	Yes, 7 AM-2:30 AM 7 days/week	N/A	N/A	N/A	N/A
Evergreen	Appointments	T-W-Th early AM gates as needed	MTC Voyager	Yes	Yes	1 of 4 lanes for appts
Trapac	70 h gate + appointments	Night gate by appt, wheeled loads only	e-Modal	No	No	No priority
CUT	Direct	No	N/A	N/A	N/A	N/A
ITS	Appointments	Sunday gate for special cargo	e-Modal	Yes	No	Trucks with appts pulled from queue if wait time near 30 min.
LBCTI	Appointments	Sat, Sun 7 AM-6 PM	e-Modal	No	No	Trucks with appts pulled if wait time over 20 min.
PCT	Appointments	No	e-Modal	Yes	Unknown	Appt trucks to main gate
SSA - A	Appointments	No	e-Modal	Unknown	Unknown	Appt trucks to main gate
SSA - C	70 h gate operation	Full night gate 4 days/week	N/A	N/A	N/A	N/A
TTI	70 h gate + appts	M-F early AM, limited; full Sat;	MTC Voyager	Yes	Yes	No priority

Source: Giuliano & O'Brien, 2007, p. 462

Therefore, as noted by the above authors, no terminal operators extended gate hours that had not already done so. The commonly accepted rationale for this reluctance to extend gate hours given by the terminal operators themselves was high labor costs of the aforementioned ILWU. Presumably, the three terminal operators that had already extended gate hours had already calculated that the benefit of moving more containers outweighed the cost of paying ILWU

wages. More specifically, the three terminals with appointment systems that pre-dated the mandate differed from the remaining 10 in two ways (Giuliano & O'Brien, 2007). First, the former were physically larger than the others so that truck chases were pre-attached and did not have to be assembled by the ILWU, thereby skirting a contractual agreement between the union and the Pacific Maritime Association (PMA) (Sharpsteen, 2011) Secondly, these terminals

had special contracts with large importers that “assured a high volume of containers processed;” this would presumably counteract high ILWU labor costs with sheer import volume (Giuliano and O’Brien, 2007, p. 465).

THE APPOINTMENT SYSTEM FROM THE TERMINAL PERSPECTIVE

The adoption of the appointment system was not in and of itself an endorsement of the system, merely a response to a mandate. The terminal operators were not initially receptive to such an idea (Giuliano and O'Brien, 2007). It seems clear why terminal operators were wary of the extended hours; however, no action would have meant that they serve all truckers within 30 minutes (one terminal did this). For many of the terminals, therefore, appointment systems were seen as the preferred option or ‘the lesser of competing evils.’ As shown in **Figure 4.3**, nine of the terminal operators chose to implement new fully-compliant appointment systems, two chose to add appointments to partially-compliant hours, and one terminal chose no action whatsoever.

Significantly, the Lowenthal Bill did not mandate that respective terminals choosing to implement appointment systems keep track of truck turn-times, a key measure of the speed in which drayage drivers can get in and out of the port. Thus, it is difficult to quantitatively determine if the mandate improved turn times. There are studies, however, that illustrate that the mandate was basically ineffective because for almost all of the terminals, less than a third of total moves

were scheduled through the appointment system (Giuliano and O'Brien, 2007). The same researchers also conducted actual counts of three different terminals, and only one of these terminals was consistently using appointments for more than a fifth of overall moves, as seen in **Figure 4.4**. Different policies were behind the differing results seen in **Figure 4.4** (Terminal B "actively promoted" the appointment system from the beginning, Terminal A was indifferent to the appointment system before making a substantial push to use the technology, and Terminal C never really promoted the technology) (Giuliano and O'Brien, 2007, p.463)

A slightly earlier study from the same team of researchers speculated that many of the terminals did not enthusiastically adopt the appointment systems for the following reasons:

"First, terminals must be flexible and organize their operations based on the nature of their business. There is great variety in type of product, number of ships served, customer requirements, and dock space. When extended hours are warranted, they are [already] offered. Second, the web-based container information systems were already providing data on container availability; hence it was unclear what additional benefit appointments would add. Third, the most promising option for improving productivity is technology, such as efficient use of OCRs, using GPS to track container movers, and streamlined cargo tracking. Fourth, an appointment system adds to the data burden of terminal operators. Finally, there is an incentive

Figure 4.4: Responses of Three Terminal Operators to the Lowenthal Bill

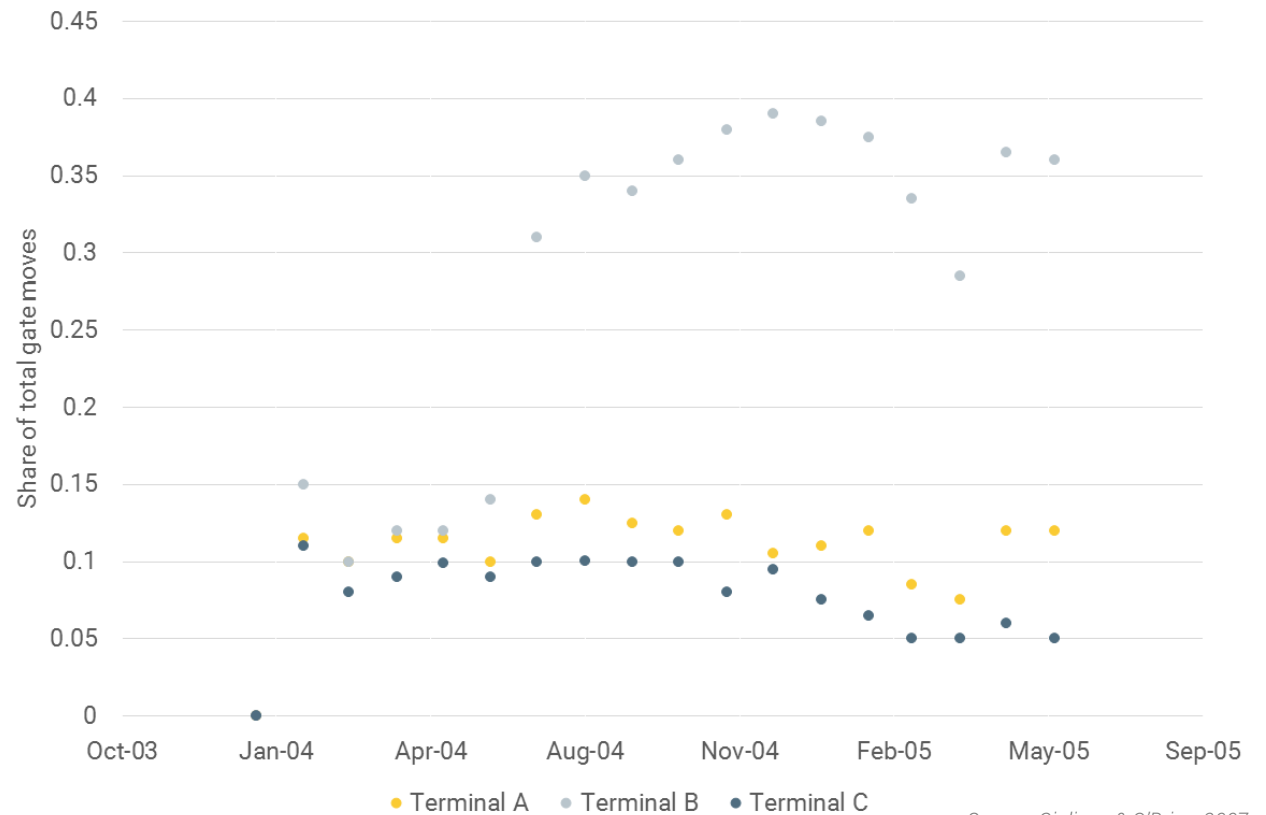

Source: Giuliano & O'Brien, 2007

to discourage appointments, since the greater the proportion of appointments, the more likely it will be that a truck with an appointment will be present in a long queue, and hence the greater risk of being fined." (Giuliano et al., 2006)

The last point is perhaps the most crucial: terminals that enthusiastically embraced appointment systems actually had a higher

chance of truckers using these systems. If the latter occurred, then terminal gates would have a more difficulty avoiding the \$250 fines (Terminal B in **Figure 4.4** would in theory have the greatest risk of being fined because of its almost-40 percent adoption rate).

Two other factors decreased the chance that the system would work as envisioned by Lowenthal

and other backers. First, the appointment-based incentive system was almost completely punitive in the sense that it did not give any direct advantages to the terminal operators for cutting turn times; as one would colloquially say, the system was ‘all stick and no carrot.’ Secondly, once hours were extended or appointment systems were created, terminals faced no pressure to improve overall efficiency. To avoid the 30-minute maximum and the fine, they often moved truckers with appointments to the front of the line. Such a strategy, however, hardly seems conducive to overall efficiency or equity for the port truckers (Giuliano et al., 2006). Third, enforcement was questionable because a single inspector was responsible for serving all terminals at the Ports. Between late 2003 and late 2005, this single inspector recorded some 4,000 inspections, which could “range from five-minute checks to extended observations of queues” (Giuliano et al., 2006, p. 15).

During this time, the average queue length at the different terminals ranged dramatically from 5 to 26 minutes with “maximum observed queues ranging from 5 to 122 minutes” (Giuliano et al., 2006, p. 16). Clearly this latter figure would suggest that at least some fines should have been levied; on the contrary, no fines were ever given out over the length of the study.

THE EXPERIENCE OF THE APPOINTMENT SYSTEM FROM THE TRUCKING PERSPECTIVE: THE QUANTITATIVE EVIDENCE

When assessing the relevant data, it is difficult to determine if there is one definitive response from the “trucking community” in regards to the appointment system. Looking first at the quantitative data provides some admittedly circumstantial evidence that the appointment system and extended hours did decrease mean turn times (as seen in **Figure 4.5**). The largest decline in coincides with the introduction of the Lowenthal Bill in July 2003. These results are significant at the one-percent level (Monaco & Grobar, 2005). That being said, other improvements were made at this same time (i.e. truck-recognition improvements at terminal gates), thus, it is somewhat difficult to isolate the effect of the Lowenthal System upon the efficiency of the terminals.

Figure 4.5: Average Turn Times at the Terminals

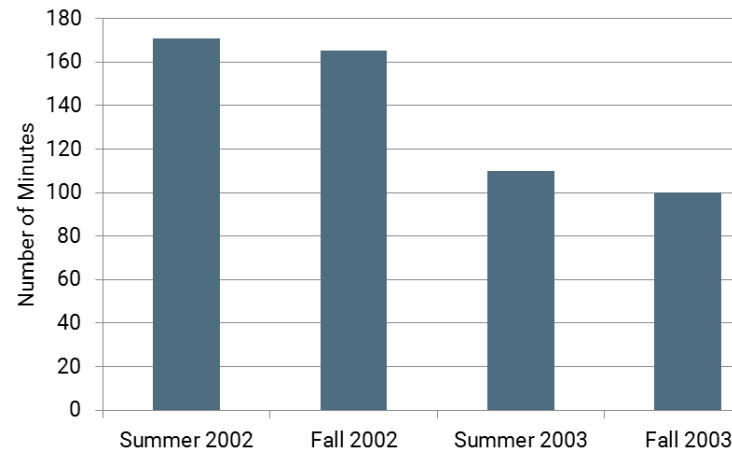

Source: Monaco & Grobar, 2005

RECENT TURN TIME DATA

While the data shown above is high quality—collected from some 2,000 truckers working for over 100 companies—it is somewhat outdated, being more than a decade old. What does more recent data say about average turn times? The Harbor Trucking Association (HTA), a trade group composed mostly of trucking company owners, has quantitatively measured turn-times at the respective terminals of the Ports over the past several years. The Chairman of the Harbor Trucking Association noted that the ILWU slowdown in 2014 impeded truckers immensely; truckers were routinely waiting three or more hours per load. To maintain 100 drivers paid by the load such companies were compelled to pay waiting time, many for the first time since deregulation (Anonymous Interview with Port Truck Drivers and with a Trucking Company Owner, 2016). However, many companies insisted on placing GPS transponders on truckers to ensure that such waiting was actually due to low productivity within the ports (and not due to poor productivity from the truckers themselves) in exchange for these payments. Spurred by the HTA, many other companies followed suit and so the slowdown may have helped this data-gathering effort. In regards to the paying of waiting time, some companies persisted after the labor crisis had passed (Giuliano et al., 2006, p. 37); many others stopped the process (Personal Interview, 2016).

These GPS transponders also allowed the Harbor Trucking Association to scrape the data and compute average turn times for all the terminals at the San Pedro Bay Ports (mean and median often differ because of the strong positive skew seen in the data).

As of 2015, median turn times were hovering at about 74 minutes (with a mean of 88 minutes) as seen in **Figure 4.6** and similar to the information shown in **Figure 4.5**. In some ways, this is impressive considering how trade has grown at the Ports. Therefore, the maintenance of efficiency here must be considered in some sense a success (albeit from an admittedly low base). On the other hand, for IOOs, such a claim must seem hollow; after all, their time is still too often spent unpaid and unproductive. The average trucker now is waiting for the same amount of time that he/she was waiting in 2003. And turn times slightly worsened in 2016 (they **increased** from an average of 88 minutes to 91 minutes, although this was not statistically significant).

The 2015 data from the Harbor Trucking Association is striking and shows a wide amount of variation, from a high median time of 99 minutes at the TraPac Terminal to a low median time of 35 minutes at Matson. These figures, however, represent an increase over the turn times that were measured in 2010 and 2013-2104 respectively (with turn time figures of 51 minutes and 60-70 minutes) (Mongelluzzo, 2015). Therefore, to conclude, turn times fell in 2003, and were further suppressed by the Great Recession, but then have rebounded steadily since then.

Figure 4.6: More Detailed Look at Turn Times

Operator	Average Visit Time (minutes)	Median Visit Time (minutes)	% of Moves Under 1 Hr	% of Moves Between 1 and 2 Hrs	% of Moves Over 2 Hrs
TraPac	117	99	0.29	0.3	0.4
Pier 400	111	96	0.23	0.41	0.36
ITS	109	93	0.27	0.4	0.33
TTI	107	91	0.26	0.42	0.32
PCT	95	82	0.32	0.42	0.26
YTI	95	79	0.35	0.38	0.27
LBCT	88	76	0.4	0.36	0.25
Pier A	87	70	0.42	0.36	0.22
STS	83	68	0.43	0.37	0.2
CUT West	79	66	0.44	0.42	0.15
WBCT	70	57	0.53	0.34	0.13
APL	59	47	0.64	0.29	0.08
Matson	42	35	0.83	0.16	0.01
Total Average	88	74	0.42	0.35	0.23

Source: "Average LA-LN truck turn times hit hour and a half | JOC.com," 2015

THE EXPERIENCE OF THE APPOINTMENT SYSTEM FROM THE TRUCKING PERSPECTIVE: THE QUALITATIVE EVIDENCE

Since 2003, several qualitative studies have attempted to determine how appointment systems are viewed by truckers. Researchers Giuliano et. al (2006) surveyed a small sample of truckers and found that the clear majority felt that the appointment system did not help

them, although a portion did believe that the appointment system had some advantages. **Figure 4.7** demonstrates some of that information.

A larger sample of port truckers were asked to rate the appointment system on a scale of 1 ("not effective") to 5 ("very effective"). The results are shown in **Figure 4.8**, with the terminals assigned a letter so as to protect anonymity of

the operators. The highest score was 2.33 (the score 2 is considered “marginally effective” and 3 is considered “effective”). All but two terminals scored below 2.

As of 2006—the time of this study—the researchers broke down those terminals into those with greater than 35 percent appointments and those with less than 35 percent appointments; the latter group actually had faster overall turn times. The authors note that this data might be affected by the fact that appointments are generally utilized by the busier terminals and at busier times, so causation is difficult to prove.

PROBLEMS AND IMPROVEMENTS IN THE APPOINTMENT SYSTEM

There were several problems that the drivers themselves cited in the appointment system. First, there was a widespread complaint that the terminals were not keeping their end of the bargain (namely that truckers would have to wait in line with non-appointment truckers and would be compelled to wait as the ILWU

Figure 4.7: Opinions on the Lowenthal by Trucking Companies

Has the appointment system...	Yes	Somewhat	No
Improved your ability to meet customer demands?	0	10	15
Had any impact on reducing turn times?	0	8	17

Source: Giuliano et al., 2006

Figure 4.8: Opinions on the Lowenthal by Trucking Companies

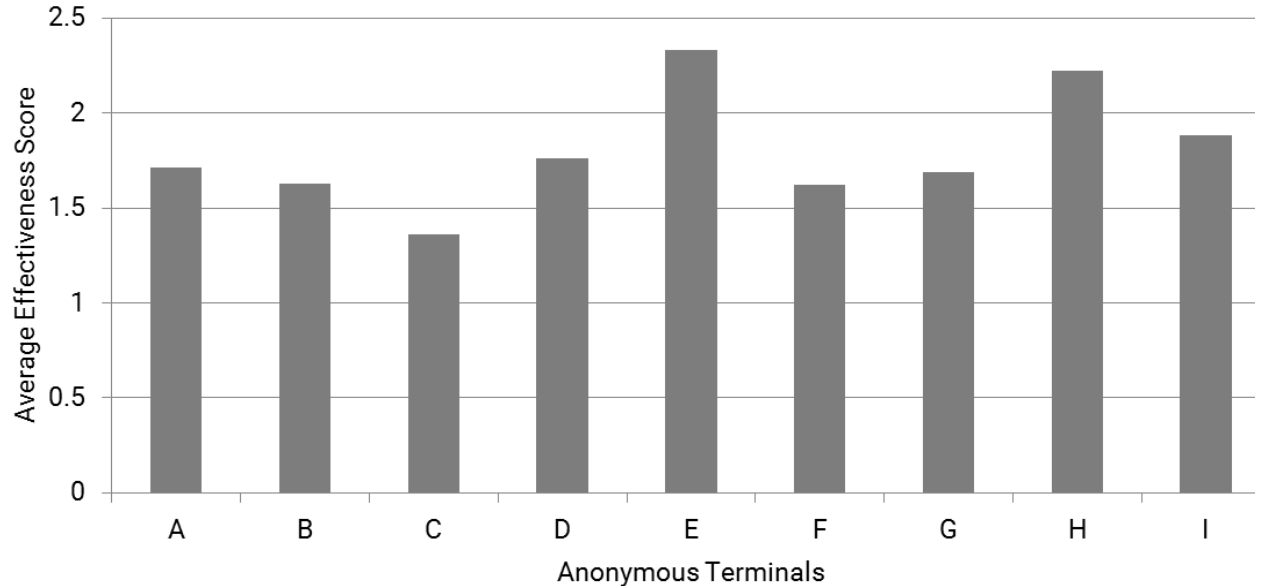

Source: Giuliano et al., 2006

searched for the container in question or for a related chassis. An investigative study queried some 27 companies representing 2,000 truckers about the appointment system and this was a common complaint (Giuliano and O’Brien, 2007). Secondly, the appointment system was utilized in a rather casual manner, with high rates of cancellation (the majority of the cancellations were caused by congestion outside the gates) (Monaco & Grobar, 2005).

Finally, there was the issue of smaller IOOs lacking the more sophisticated back-office functions that would allow greater efficiencies. Traditional trucking employers had incentives

to invest in these technologies so as to improve efficiency (because they would be paying wages for waiting times). Larger firms reported a more favorable view of the appointment system as of 2006 (possibly they had invested more in back-of-the-house scheduling software and human resources, but also possibly because they had specialized relationships with certain terminals). Indeed, findings suggest that specific matchups between established (and thus larger and more technologically organized) trucking companies on one hand, and certain terminals on the other can produce turn-times that are significantly below the mean (Monaco and Grobar, 2005).

MOVING TO MANDATED APPOINTMENT AT THE SAN PEDRO BAY PORTS

In recent years, many terminals have independently moved away from the voluntary appointment system and have adopted mandatory appointment systems (most have also kept the extended hours). This action is notable because AB 2650 is no longer binding on most of the terminals due to the fact that most of them have gradually extended terminal hours. Furthermore, the terminal operators collectively created PierPASS in 2005; thus, the mandate for individual appointment systems is no longer binding (Giuliano, 2006). PierPASS charges a fee for containers moved during daytime hours and uses that money to subsidize longer gate hours and higher labor costs. Interestingly, PierPASS was begun by the terminal operators themselves in response to a threat by Mr. Lowenthal to pass a more aggressive version of AB2650.

As of 2015, five terminals already had mandatory appointment systems, and in 2016, this number is set to double (meaning that 10 of the 13 terminals—nearly 2/3rds of the terminals at the Ports—will be utilizing appointment systems by the end of 2016) (“Truck Appointments Expanding,” 2015). Two of the three remaining terminal are planning to introduce appointment systems in the future “on a longer timeline” (“Truck Appointments Expanding,” 2015). This is the result of 10 terminals adopting an “appointment system action plan”, which

entailed certain guidelines for the adoptee terminals (listed below).

1.Appointments will be mandatory at all participating terminals, at all times, and for all import loads (with the decision about requiring them for exports to be undertaken at some later time.

2.All terminal appointment systems must be accessible from the PierPASS website (“Truck Appointments Expanding,” 2015).

Because these modern appointment systems are not under the Lowenthal System, terminals are also allowed to impose penalties for missed appointments. That being said, such steps are not particularly common, according to interviews, although specific policies vary by terminal (Anonymous Interviews with Port Truck Drivers, 2016).

The changes outlined above certainly have the potential to improve the functioning of the overall system and improve the turn-times for truckers (which improves their economic functioning and helps the environment). Nevertheless, it is impossible to predict exactly how mandatory appointment systems will affect the logistics system. The following are several scenarios that detail the possible changes that could occur over the next decades in this part of the supply chain. Within such scenarios, possible interventions will be proposed.

CURRENT CONDITIONS AND TRENDS

ORGANIC CONSOLIDATION OF APPOINTMENT SYSTEM PORTALS

Under this scenario, port traffic continues to grow as trade with China, Vietnam, and other Pacific economies expand. Further consolidation of shipping into mega-ships is assumed to continue, perhaps with a slight slowdown in the relative growth rate of the ships. Periodic labor shutdowns between the ILWU and the terminal operators are a likely possibility, considering the strikes of 2002 and the slowdown in 2014.

Under the PierPASS system, almost all terminals are planning to utilize a mandatory appointment system for all imports (10—and soon 12—of 13 terminals will be utilizing mandatory appointment systems). The fact that the appointment systems were made mandatory by the terminal operators themselves and not by the government, as was done through the Lowenthal Bill, is encouraging because it suggests more follow through from the private terminal operators. Furthermore, the fact that PierPASS is now the platform on which the different appointment systems can be accessed is a step in the right direction. Considering that the Ports are composed of 13 terminals, maintaining a centralized portal for the appointment system is crucial; indeed, the Port of Vancouver, when implementing mandatory appointment systems, struggled mightily with only four terminals (Mongelluzzo, 2015). The

PierPASS website also has some other terminal-specific links such as live traffic cameras and live traffic maps.

The scale of the problem is larger at POLA and POLB than in Vancouver. That being said, there is reason to believe that a mandatory appointment system might function better here than in Vancouver because the latter port's system was put in place seven years ago by a government mediator. Presumably, the terminal operators in LA and Long Beach now see a market-based case for the appointment system that perhaps doesn't exist in Vancouver. Secondly, the Vancouver appointment system suffered because there was very light trucking demand throughout the night; few truckers wanted to make appointments at night. Thanks to PierPASS, overnight demand at the Ports is already high (in fact it is higher than daytime demand) (Mongelluzzo, 2012).

As mentioned, the Ports are currently utilizing a single portal for the numerous appointment systems (that portal being the PierPASS website). That being said, the terminals are currently utilizing different systems that do not interact with each other. This lack of interaction can be a problem because often truckers will drop off a container in one terminal and then must pick up a container in another. Dual appointments are usually no longer possible at the Port of Vancouver because "the individual terminal systems aren't integrated and don't talk to each other" (Mongelluzzo, 2015, p. 12). Improving such moves could improve the

economic condition of truck drivers but there is no obvious desire on the part of different terminal operators to collaborate on this aspect of the supply chain. Conversely, there could be resistance to collaborate this closely because of the inherent competition between the different terminals. In any case, terminal operators will likely see benefits from collaboration on the appointment system website, but cooperation between the terminals in minimizing overall turn times within the entire port system are doubtful without government action.

Furthermore, it seems likely that there will be pressure from the truckers and from the terminals to consolidate around a fewer number of appointment systems or even a single appointment system (possibly eModal, as this system is already heavily utilized by the different terminal operators and which has a strong relationship with POLA and POLB leadership). This consolidation will be helpful to the truckers (one appointment system would theoretically allow a truck to service any terminal). And yet, the decision of centralizing appointment systems ultimately lies with the terminal operators and not with the truckers.

MORE ACCOUNTABILITY AND PRODUCTIVITY FROM BETTER DATA

The second process that we believe will occur through the market is an increased knowledge of terminal turn times because of the work done by the HTA, which has taken advantage of technological advances in order to provide members and subscribers with information on

terminal efficiency through the placing of GPS sensors to trucks. This group has produced quarterly reports detailing total turn times (which are broken down again to time outside the gate and time spent within the terminal). This increased information may well allow trucking companies to put some pressure to bear on the terminals, who have historically felt little pressure from trucking companies and who still seem to think of truckers only after all other considerations have been dealt with. Such information could for the first time provide a dynamic and constantly changing view of productivity within the terminals. The granularity of the data may finally allow the truckers to benefit in some degree by picking terminals that are quicker. Drivers who are employees of trucking companies have the potential to experience decreased waiting times because they are being paid hourly wages, which encourage employers to seek more efficient terminals; after all, long waiting times hurt the latter group's bottom line. Other new Smartphone-based apps allow real-time information to be easily accessed by drivers and seem likely to offer comparable turn-time information to IOOs, perhaps at a fraction of the cost of the aforementioned data (Mongelluzzo, 2016).

The above information alone will not be a solution for long waiting times, however, because IOOs bear most—if not all—of the costs of delays even as they often have no effective personal choice in deciding which terminals to service; trucking companies contracting with IOOs sometimes even forbid "their" truckers from contracting with

other companies (Bensman, 2009; Anonymous Interview with Port Truck Drivers, 2016). These rules have been effective in their purpose; lateral moves between trucking companies are quite rare and interviews have revealed widespread formal or informal sanctions on drivers that either accept jobs from other companies or refuse to take a job from the trucking firm that is contracting with them (Smith et al., 2010). Therefore, information on turn-times may be interesting to trucking company owners—and it may even cause some to change which shipping lines that such companies serve—but the costs for waiting are felt most acutely by truckers themselves, a group which cannot easily switch terminals. Thus, real pressure on the terminals to speed up and compete will be limited by the existing power structure of the industry.

It is possible, however, that the relatively small number of traditional trucking companies that utilize traditional employees—estimated at less than 10 percent of truck drivers at the Ports (GCR Management Consultants, 2007)—may become more competitive in comparison to the IOOs in the future. These more traditional firms, often referred to as “high-road” trucking companies, already compensate for higher labor and equipment costs with higher productivity derived partially from larger volumes allowing specialized deals with terminals (Bensman, 2009; Giuliano & O’Brien, 2007) and faster turn times therein. With the greater knowledge from more accessible and advanced data, such firms do maintain the incentive to pick and choose terminals and times that minimize the

payouts they must make to their drivers for unproductive time. There is some research to suggest that traditional trucking companies also invest more money and resources in advanced telecommunications and back-of-the-office human resources (Bensman, 2009; Monaco & Grobar, 2005). It seems quite likely that while appointment systems have been shown to improve overall productivity, the greatest relative increase in productivity may be seen in the companies that have already made such investments in organization and advanced scheduling.

There is also a second point that would support the view that such data might help traditional employees more than IOOs: the former group belongs to companies that not only maintain incentives to decrease turn-times, but may have the financial abilities to subscribe and analyze turn-time data to help the truckers minimize this metric. For example, the Harbor Trucking Association notes that this is one of the helpful ways that this information could be employed, to “zero in on [truckers’] practices that consistently contribute to unacceptable turn times” (“Harbor Trucking Association Launches LA-LB Truck Mobility Report,” 2013). According to Alex Cherin, the Executive Director of the Harbor Trucking Association, “This is not a ‘got’cha thing.’ Truckers want to take responsibility for problems that they cause, and terminals feel the same way” (“Harbor Trucking Association Launches LA-LB Truck Mobility Report,” 2013). IOOs may maintain a more direct financial incentive to limit turn-times, but such truckers may not have the

financial ability to purchase the data (the port-wide data is free, but more granular data costs money). And even if they could buy such data, problems of agency described above would presumably limit their flexibility in utilizing this data.

It is important to note that a minority of trucking companies employing IOOs do pay for waiting times to this group of workers; that being said, the percentage of companies that do this is relatively small (Anonymous Interviews with Trucking Company Owners and Truck Drivers, 2016) and those that do only generally do this after 90 minutes; the exception occurred in 2014, when trucking companies could charge far higher rates as a result of the port slowdown and thus, some trucking companies paid for all waiting time. However, once the port returned to its normal level of productivity, such practices were largely discontinued. Thus, in a normal economy, we are predicting that traditional trucking companies may see some productivity advantages as a result of the above factors.

INCREASED USE OF FREE-FLOW SYSTEMS

Free flow cargo systems are systems of terminal off-loading in which terminal operators unload containers and group them together so that truckers can theoretically pick up any container. Free-flow systems eliminate the constant problem within the terminal whereby dockworkers must move other containers (which are often stacked “four or five containers high and up to six containers deep” (“PierPASS

Announces Free-Flow Program to Speed Cargo Through Ports of Los Angeles and Long Beach | PierPASS,” 2014). These unproductive moves outnumber “productive moves” by a factor of some three to one (“PierPASS Announces Free-Flow Program to Speed Cargo Through Ports of Los Angeles and Long Beach | PierPASS,” 2014). If one of the main complaints about the mandated appointed system was that delays were merely transferred from outside the gates to inside the gates, free flow systems combined with new, mandatory appointment systems could speed up the system and improve efficiency. Indeed, POLA has had success in “cutting import container deck times by 50 to 75 percent in a pilot study (Mongelluzzo, 2015). Furthermore, data from 2015 confirmed total turn times at the Ports were on average 89 minutes, only 19 minutes of which were spent waiting outside the gates. A more efficient appointment system would mean little without efficiency gains within the gates.

This efficiency is specifically due to the fact that with a free-flow system, the ILWU utilizes a “top pick” crane in which, “the machine basically stays put in one spot and delivers one container after another to drivers as they arrive at the single stack” (Mongelluzzo, 2015, p. 20). Without a free-flow system, the crane spends an average of two minutes lifting and laterally moving each container (Mongelluzzo, 2015).

In spite of the potential for free-flow systems, there are several problems in regards to expanding the system. First of all, a beneficial

cargo owner (BCO) that wishes to use free-flow cargo at the Ports must ship at least 80 containers/ship, which would preclude smaller importers from using the service. Companies can combine forces, which seems quite likely, following the trend of general industry consolidation.

The terminals using free-flow systems also mandate that shippers provide adequate trucking to move at least 80 containers/shift (“West coast MTO agreement marine terminal schedule 1: Naming certain rules,” 2005). Trucking companies utilizing IOOs may have modest advantages from utilizing this system, but it is really the truckers themselves in an IOO system that would benefit from more rapid move times because these truckers are paid by the load, not by the hour. The company owners utilizing IOOs may not find it convenient to organize labor in this way to guarantee at least 80 moves/shift (particularly considering the human resources and scheduling software that is generally antithetical to IOO-dependent companies). On the other hand, conventional companies with trucking employees would likely expend the necessary effort to utilize free-flow systems because waiting times can be minimized and productivity increased. If there are large productivity advantages for free-flow systems, as the evidence seems to suggest, traditional trucking companies may grow in popularity.

One wildcard that is difficult to predict is the effect of companies like Cargomatic onto the trucking

scene. This company—and others like it—utilizes a Smartphone map to match labor and jobs in a manner similar to what is done by companies like transportation networking companies, such as Uber and Lyft. Such companies could play a role in port trucking; indeed one of the central claims of these systems is that it democratizes trucking by allowing individual truckers to benefit from free-flow systems that only larger importers can currently use. That being said, Cargomatic is currently downscaling and is clearly in trouble financially (Hirsch, 2016). There are many unsolved issues that would inhibit this trend including issues of insurance. Furthermore, it is unclear whether Cargomatic would be able to reach a market density to more or less guarantee the terminals that they could be cleared consistently (as is currently done by shippers).

A wider utilization of free-flow systems is also complicated by the fact many analysts believe that truckers serving such a system must utilize off-dock storage yards to transfer the containers again and if necessary, re-sort them. This would have profound results for neighboring communities who would bear the brunt of the increased efficiency through more truck trips, more pollution, and more noise. Ultimately, gains in efficiency could lead to increased greenhouse gas emissions and further environmental degradation. This must be balanced against the fact that a wider adoption of free-flow systems could improve the economic condition of traditional trucking employees in relation to IOOs. After all, “peel off requires communication

in real time among trucking companies, terminal operators, and cargo owners.” In the diffuse nature of the IOO system, it is difficult to see where the necessary coordination would come from to make success possible. The incentives for company owners who employ IOOs simply do not run in that direction.

ENVISIONING SUSTAINABILITY, EQUITY, AND COMMUNITY POWER

The ideal situation in the port trucking and appointment system arena would be at once environmentally sustainable and equitable to the port truckers. As mentioned above, there emerges an inherent tension between efficiency and environmental goals. After all, a more efficient system could lessen pollutants and noise from idling—while also improving the economic lot of truckers by allowing more runs/day (and perhaps also placing pressure upon the IOO-based systems)—and yet, it must be noted that like truck-only toll lanes and other schemes which will be discussed below, gains in efficiency could well allow more trips overall (and thus contribute to more greenhouse gas emissions, more noise and diesel pollution, and a poorer environment in the southern part of LA County generally).

An ideal system would balance efficiency, economic improvement among the port truckers, and environmental protection. In some sense, ending the IOO system would help on all these fronts. On the first and second point, it

would shift the balance back to a more efficient system that encourages more sophisticated scheduling software and more back-of-the-house human resources—minimizing waiting time at the terminals—while boosting pay and benefits for port truckers. This would also ensure that trucking companies would have a more immediate desire to work with terminal operators and the ports to minimize wait time. Finally, a more effective system would limit idling emissions per container moved. That being said, there are always trade-offs with such systems and a more efficient appointment system—especially combined with truck-only toll lanes—would almost certainly encourage more truck trips. If current diesel trucks are not replaced with cleaner fuels, such a strategy could erode the health and safety for local residents and increase greenhouse gas emissions.

STRATEGIC INTERVENTIONS: POSSIBILITIES FOR INCREASED EFFICIENCY AND SHIFT IN POWER TO TRUCKERS

This proposal describes a scenario in which aggressive, but realistic steps are taken in the future to improve the appointment system and thus contribute to the environmental health of the port communities (and of the truckers themselves), while promoting greater (and more equitable) economic outcomes for the port truckers). Such strategies will contribute to the goal of reaching a system that balances

environmental, social, and economic needs (although there will always be tension between these aims). The strategies are shown below. Below each strategy will be an exploration of the power dynamics that affect how change could occur.

ADOPTION OF THE VANCOUVER MODEL

Several years ago, truckers at the Port of Metro Vancouver initiated a strike in protest of low wages (most Vancouver truckers at the time were operating under an IOO system). As a result, a government mediator was called in and mostly eliminated the IOO system in favor of a more conventional employee model in which the Port of Metro Vancouver mandated licenses to enter the port (only trucking companies that used employees, utilized appointment systems, and attached GPS transponders to trucks could receive such licenses) (Anderson, 2009). Utilizing these GPS machines, the Port of Metro Vancouver began “charging terminals a penalty of \$50 if the transaction time exceeds 90 minutes. An additional \$25 fee [was] added at two hours, another \$25 at two and one-half hours, and an additional \$20 for each half-hour after that” (“Vancouver penalty system cutting truck turn times,” 2014). Within less than half-a-year, terminals paid out some \$1 million dollars in fines.

The above fee for time exceeding 90 minutes is a potential strategy that could be applied in the Ports so as to improve efficiency, help the port truckers maintain low turn times, and also possibly cut emissions from idling. As landlord

Ports, POLA and POLB could each write this into their contracts when negotiating with terminals for leases or the State of California could likely mandate such a system. This would differ qualitatively from AB 2650 because the latter was only concerned about waiting time outside the terminal. This move would require the following:

- A concerted effort by port truckers, perhaps joined by local community groups concerned about air quality (after all, air quality degradation inside the gates and air quality degradation outside terminal gates makes little difference to residents).
- The money raised from fines could be split up between the truckers who had to wait and the community (the money to be placed in a community fund for regional air quality efforts and neighborhood tree-planting and park-creation efforts).

This fine would internalize inefficiencies in the system and environmental harms. If severe enough, it could bring down the number of truck moves.

The Vancouver scheme did not offer any exemptions for the terminal operators, who are still attempting to include such exemptions as “dual transactions (dropping off one container and picking up another), trouble-ticket transactions, and requests by drivers to inspect empty containers (such as for food-quality cleanliness)” (“Vancouver penalty system cutting truck turn times,” 2014). Some of these exemptions such as the “trouble-ticket”

exemption may encourage more responsible behavior from truckers and perhaps should be kept in the Ports. Other exemptions such as the dual transaction exemption certainly could minimize pressure among terminal operators to keep turn-times low (and thus should be rebuffed if the goal is efficiency).

The above strategy would presumably lead to efficiency gains within the terminal gates—further encouraging the use of free-flow systems—and help the port truckers earn more money by minimizing turn times. That being said, the political fight to get this would be difficult and passage of something like this would presumably only occur during or immediately after a labor shutdown (as occurred in Vancouver). Labor organizing strategies must consider the fact that port truckers in California almost certainly would face a more hostile response from the federal government than the response that the Canadian government gave to the Vancouver truckers.

PIERPASS REFORM

PierPASS creates incentives for truckers to wait at the gate before 6 PM (the time after which gate moves are not charged). Furthermore, the fact that terminal appointment systems are unreliable often encourages truckers to wait—often idling—outside the Port gates. After all, the current charging scheme switches from a charge to no charge at all at or after 6 PM. We recommend the utilization of big data to create more dynamic pricing systems for PierPASS, which would certainly have powerful

downstream effects on the individual terminal appointment systems by further spreading traffic movements away from the early evening hours (immediately after the 6pm changeover).

A more dynamic system would introduce a more flexible charging scale that would be superior to the binary system now in operation with PierPASS. Big data sets—increasingly compiled in real-time by private organizations like the Harbor Trucking Association—are already available. A port-wide pricing scheme based on such data might require the installation of GPS sensors on all trucks because of the Harbor Trucking Association’s reluctance to share proprietary information. The Ports should work with PierPASS to explore the legality of requiring all trucks at the Ports to install GPS sensors, as was done in Port Metro Vancouver. This data would be valuable to the Ports in gaining better information about truck moves. The Ports could share this information with the individual terminals and could use this information to understand ways to expedite dual moves, data that would support the Ports and the terminals in implementing the “Vancouver Model.”

The relative political weakness of the port truckers means that the Ports would likely face little resistance in imposing this GPS mandate. The terminals would likely disapprove of this mandate, but their disinterest in the truckers—combined with the fact that GPS sensors are already being widely used and indeed often mandated by trucking companies—could result in an uncontroversial adoption.

Changing PierPASS to be more responsive to trucking flows would likely face some pushback from the terminal operators; representatives of the terminal operators would likely see any attempt to impose changes from the government negatively. That being said, the government—specifically the State of California—could play a role in advancing PierPASS forward by drafting legislation that would specify a more flexible pricing scheme. That strategy worked in 2005 when Lowenthal drafted another, harsher bill that inspired the terminal operators to create PierPASS. The charge for PierPASS, currently given back to the terminal operators in order to pay for extended gate hours and increased labor costs, should be mostly maintained. The fact is, terminal operators will likely not lose money, but efficiencies will be maximized.

IMPROVE CONDITIONS AT THE TERMINAL FOR PORT TRUCK DRIVERS

One issue that emerged from several interviews with port truck drivers is the problem of waiting times outside terminal gates (Anonymous Interviews with Port Truck Drivers, 2016). While waiting times have certainly declined—perhaps at the expense of longer waiting times within the terminals—truckers still complained about long waiting times outside the gates and the lack of facilities such as bathrooms. While installing bathrooms might seem somewhat banal, it could make a difference for truck drivers. This act could be done through the Port leadership requiring facilities at the respective terminals. The Ports are landlord ports and so could write this mandate into the contract.

The Port leadership must be pressured by the Port truckers to build bathrooms. A more highly organized trucking movement could tackle this issue and bring up quality-of-life issues in the job (although this may have to wait until after other victories have been won by port truckers, such as a minimum wage and union representation).

EXPERIMENT WITH FREE-FLOW CARGO MANAGEMENT STRATEGIES

The Ports should keep experimenting with free-flow cargo methods. Such methods are undoubtedly more efficient than other methods. In combination with a more efficient PierPASS, an appointment system, and possible truck-only toll lanes, free-flow methods could lead to more reliability in the system. That being said, such a strategy would almost certainly increase the number of cargo moves possible through the Ports. This would have negative overall consequences for the local—and considering global warming effects—the global environment. An expansion in free-flow cargo movement would also create large and probably negative land use effects in the communities surrounding the Ports. After all, free-flow cargo moves often use nearby areas to transload cargo, which is then often carried to the Inland Empire.

The Ports should work with local communities to determine if there are already existing plots of land that could be used for the transloading of cargo. Residents of surrounding communities, however, will likely oppose such efforts and so the Ports should consider a special fee that could be adopted for free-flow cargo that could

be used for local environmental goals like the placing of air filters on homes or the planting of trees. If GPS sensors were placed on trucks, the Ports would have an accurate idea of how—and where—free-flow cargo movement is impacting local communities.

PORT-MANAGED CONGESTION MAPPING (REAL-TIME)

As mentioned earlier, the Port of Oakland created a system that created an app showing real-time congestion mapping. The Harbor Trucking Association is somewhat doing this although not yet in real-time. Considering the competitive nature of the Ports within a global logistics system, the Ports will probably start doing this fairly soon, and yet pressure from the port truckers will likely speed this up. Furthermore, the nature of the IOO system means that a system that in theory allows more information will be limited as long as the information cannot allow a change in terminals (due to limited agency).

CONTAINER TERMINAL AUTOMATION

BACKGROUND

Technological advancement has always played a major role in improving the efficiency and capability of the goods movement system. One particularly important advancement was the development of containers after WWII, referred

to as “containerization”, which revolutionized international shipping among nations, produced significant growth in international trade, and affected the global economy by aiding the rise of globalization. While containerization produced many benefits, including significantly reducing shipping costs and port congestion, it also displaced a large segment of dockworkers who were no longer needed to handle cargo by hand. The International Longshore and Warehouse Union (ILWU), which is the single union that organizes all ports on the west coast and holds a great amount of leverage when negotiating port related decisions, initially opposed these technologies but eventually conceded in exchange for higher wages for existing workers and buyouts for displaced ones.

Today, terminal automation is the new technical disruption that ports face. As shipping lines employed economies of scale by operating larger vessels to reduce operating costs, there developed an increased pressure on terminal operators and labor to improve container handling efficiency in order to keep up with the increased number of containers that larger ships carry. Terminal operators who are not capable of handling a large vessel’s containers efficiently risk having cargo diverted to a different terminal, within or outside the region that can provide better service or lower costs (City of Los Angeles Harbor Department Planning and Economic Development Division, 2014). Automation technology is one of the strategies that a terminal operator can utilize to improve efficiency or lower costs. However, considering

the high cost of terminal automation and the varying circumstances of terminal operators, certain terminal operators may elect to pursue non-automation strategies to improve efficiency or limit how much technology is implemented.

Overall, container terminal automation is associated with improvements to terminal efficiency and capacity, terminal competitiveness, worker safety, and environmental impact, but it also reduces demand for longshore labor causing a significant reduction in longshore jobs. The remainder of this section reviews relevant literature to understand the basic structure of container terminal operations, current trends in terminal automation, and the impacts of terminal automation with an emphasis on labor and the community.

CONTAINER TERMINAL OVERVIEW

Container terminal operations consist of three sections as seen in **Figure 4.9** to transport and store containers: 1) quayside interchange; 2) container yard/horizontal transportation; and 3) landside interchange.

A basic order of operations between the three sections includes a crane to load or unload containers from a vessel, followed by a transport vehicle to carry containers to a container yard where it will be placed in a stack and stored until it is moved to its next transport, and then repeated on the landside exchange with trucks or trains (**See Figure 4.10**).

Quayside Interchange

Quay, or gantry, cranes are used for loading

Figure 4.9: Container Terminal System

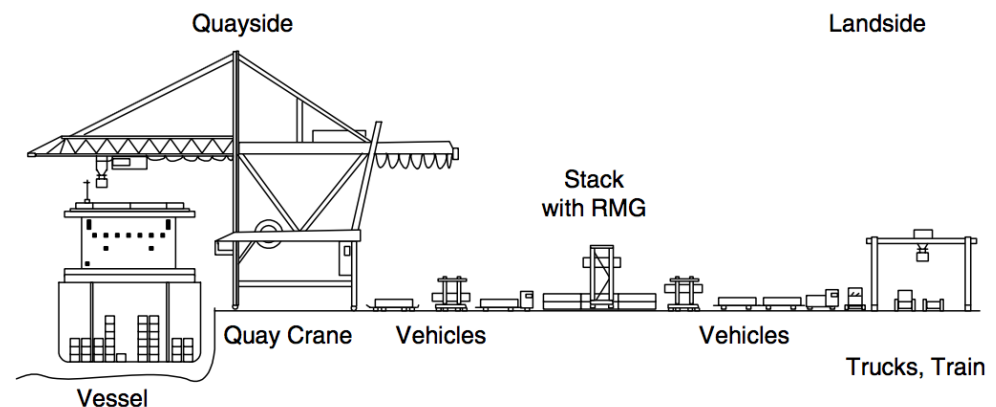

Source: (Voß, Stahlbock, & Steenken, 2004)

and unloading containers from vessels to place on vehicles for horizontal transport within the terminal. Quay cranes use trolleys that are equipped spreaders and devices that pick up the containers. There are two types of quay cranes: single-trolley cranes and dual-trolley cranes.

Single-trolley cranes are man-driven, while dual-trolley cranes utilize both man-driven and automated processes. With dual-trolley cranes, the main trolley (man-driven) moves the container from the vessel to a platform and the second trolley (automated) moves the container from the platform to its next transportation. In

both single-trolley and dual-trolley cranes, the crane driver is supported by a semi-automatic steering system (Voß et al., 2004).

Container Yard/Horizontal Transportation

Once containers have been unloaded from the vessel, transport vehicles move them to a container storage area where they will wait for the next transport. Container storage areas are usually separated by different stacks (or blocks) to differentiate areas, such as export, import, empty, or special containers that cannot be stacked normally (e.g. dangerous goods, over-height/over-width containers, or containers that need electrical connections).

A variety of vehicles can be used for the horizontal transport for both the quayside interchange and the landside operation. There are two classifications for horizontal transport vehicles. The first class consists of vehicles that are not able to lift containers by themselves and depend on cranes for loading and unloading, such as trucks with trailers or multi-trailers, and automatic guided vehicles (AGVs). AGVs are typically only employed where labor costs are high, such as at ECT/Rotterdam and HHLA/Hamburg (Voß et al., 2004).

The second class of horizontal transport vehicles, which includes straddle carriers (SC), forklifts, and reachstackers, are able to lift containers by themselves without assistance from a crane. Straddle carriers are considered the most important vehicles of this class because they have the flexibility to transport containers and also stack containers in the yard; for instance, they can act as an unbound crane. SCs are traditionally man-driven but automatic straddle carriers that utilize GPS for accurate position and routing have been developed, such as the one at Patrick Terminal/Brisbane, and are becoming more utilized. They are often referred to as automated lifting vehicles (ALVs) due to their ability to lift containers.

A second category of cranes that is used for stacking containers in the container yards consists of rail mounted gantry cranes (RMG), rubber tired gantries (RTG), and over-head bridge cranes (OBC). Although rail mounted gantry cranes are not the most flexible due to the fixed rail infrastructure, they are considered the most stable and two RMGs are often employed in conjunction with each other to increase productivity (Voß et al., 2004). This Double-RMG system consists of two RMGs of

Figure 4.10: Container Terminal Operations Flowchart

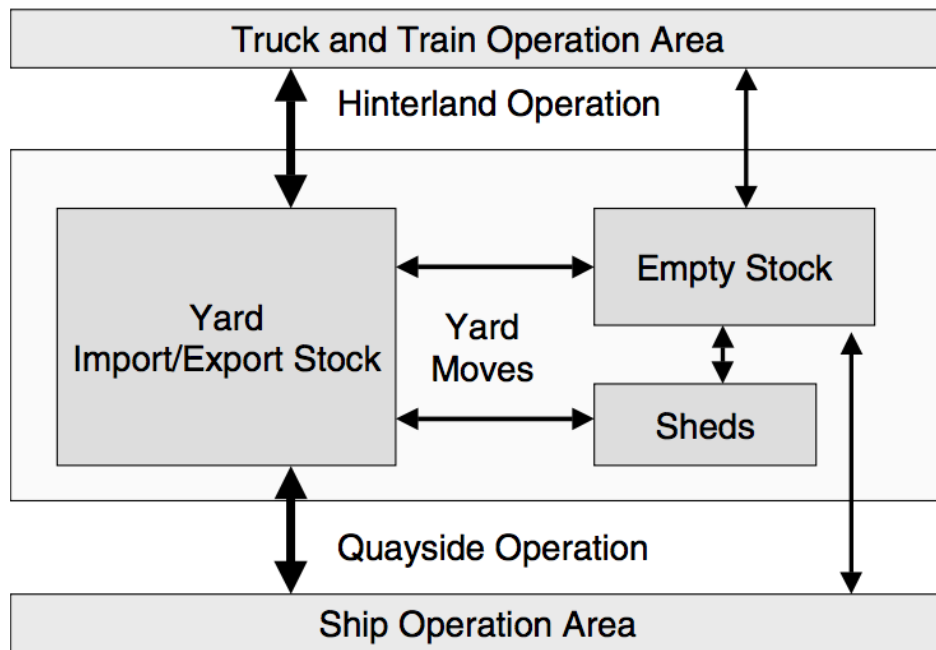

Source: (Voß, Stahlbock, & Steenken, 2004)

different height and width to allow the systems to pass each other and avoid the “handshake area”, which leads to slightly higher levels of productivity. Gantry cranes can be man-driven or utilize automatic driverless technology.

In addition to the aforementioned two main categories of cranes, mostly common in Europe and Asia, a third category exists that is more common in North America. This type is an on-chassis system in which containers are stored on chassis rather than being stacked on top of each other. This system is simpler in terms of stacking logistics but it is also more space demanding.

CONTAINER TERMINAL AUTOMATION OVERVIEW

In 2012, AECOM, a private planning firm, conducted a study on terminal automation for POLA and defined automated terminals as terminals with at least some container handling equipment operating without direct human interaction for 100 percent of the duty cycle of the equipment (City of Los Angeles Harbor Department Planning and Economic Development Division, 2014). Cases can include drivers who have been physically removed from the cranes or cases where drivers remain in the equipment cabins but are not needed for the entire duty cycle. Within AECOM’s 2012 study, there are two primary types of automated container terminals:

Automated Stacking Cranes (ASCs)

ASCs are rail mounted gantry cranes (RMGs) that lift and transport containers along a fixed row to their new destination within the row. They are generally aligned perpendicular to the berth and interface with the ends of the stacks of the terminal. ASCs mostly function without human interaction and can be driven remotely as needed. “ASCs can be fed by automated guided vehicles (AGVs), automated straddle carriers, manual shuttles, or tractors and terminal chassis can also be used within the same approximate terminal footprint.” (City of Los Angeles Harbor Department Planning and Economic Development Division, 2014)

Cantilever RMGs

This terminal design utilizes cantilever RMGs that are aligned parallel or perpendicular to the wharf to lift and transport containers in a high density layout. It differs from ASC systems since the number of RMGs is not fixed, meaning land and water side rows can have different numbers of RMGs. Cantilever RMGs are usually serviced by man-driven horizontal transportation vehicles.

According to AECOM’s report on terminal automation, the ideal style of horizontal transport is still up for debate, but most automated terminals under development focus on the ASC system. Terminals in high labor cost areas such as POLA are likely motivated by the ASC’s design potential for reducing overall operating costs by allowing for cranes and horizontal transport vehicles to be automated (City of Los Angeles Harbor Department Planning and Economic Development Division, 2014).

CURRENT CONDITIONS AND TRENDS

There are currently five automated terminals across Asia, three of which use cantilever RMGs, and five automated terminals across Europe that all use an ASC system. In North America, there is only one existing automated terminal, which is an ASC terminal in Norfolk, Virginia.

There are currently several terminal automations underway, including an ASC system for a portion of the TraPac Terminal at the POLA, an ASC system for the Middle Harbor terminal at the Port of Long Beach, and an ASC terminal at the Port of New York/New Jersey (City of Los Angeles Harbor Department Planning and Economic Development Division, 2014).

The TraPac Terminal became the first automated port on the west coast when it completed its partial automation in 2016 (POLA 2014). TraPac’s automation process was a part of a larger infrastructure project that began in 2008 and also included on-dock rail, a new wharf, wharf upgrades, buildings, and terminal gates. The cost of the total project was \$510.3M (The Port of Los Angeles, 2014).

The Middle Harbor Terminal automation is scheduled to complete in 2019. Middle Harbor’s automation process is a part of the Middle Harbor Terminal Redevelopment Project, which will combine two aging shipping terminals into the self-proclaimed greenest, most technologically advanced container terminal in the world (“Port

of Long Beach - Middle Harbor," n.d.). The redevelopment project will also include on-dock rail, new wharves, and wharf upgrades. The project has gone over budget twice due to construction issues and is currently at a total of \$1.3 billion (Dines, 2013; "Port of Long Beach - Middle Harbor," n.d.).

According to the Port of Long Beach, the Middle Harbor Redevelopment Project is expected to:

- Dramatically reduce air pollution and health risks as new zero-emission equipment and efficiencies are built into the terminal
- Create about 14,000 permanent jobs in Southern California
- Generate 1,000 temporary construction-related jobs a year over nine years
- Implement aggressive environmental measures of the Green Port Policy and San Pedro Bay Ports Clean Air Action Plan
- Reduce traffic impacts through increased use of on-dock rail ("Port of Long Beach - Middle Harbor," n.d.)

To improve air quality and reduce environmental impacts in accordance with the Port's Green Port Policy and the San Pedro Bay Ports Clean Air Action Plan, the Middle Harbor Redevelopment Project includes:

- Shore power for ships
- Expanded on-dock rail to shift more cargo shipments from trucks to trains
- Cleaner yard equipment
- Electric stacking cranes

- Green Flag Vessel Speed Reduction program requirements
- Use of low-sulfur fuels for ships' main and auxiliary engines
- "Green building" (LEED) environmental standards
- Storm water pollution prevention
- Solar panels
- Reuse of recycle waste materials such as concrete, steel, copper, and other materials during construction ("Port of Long Beach - Middle Harbor," n.d.)

FUTURE TERMINAL AUTOMATION

It is difficult to predict how many terminals will transition to automation technology in the future because this decision depends on each terminal's financial situation, labor landscape, and political context. Surely, terminals operating in a high labor cost area are more motivated to automate, but the decision to automate will likely be determined based on cost benefit analyses with the terminal operator's bottom line in mind. Cost-benefit analyses are extremely difficult to conduct due to each terminal's varying circumstances such as cost structures, lease rates, business models, and future business plans, that guide their decision making process regarding terminal automation. Since terminal operators compete with one another, this type of information is not readily available. Without access to each terminal's cost-benefit analysis regarding terminal automation or all the necessary information to conduct the investment analyses, it is unlikely to predict which terminals will automate and when.

With that being said, there are currently two proposed terminal infrastructures that are considering automation. The APL/EMS-Pier 300 Terminal has completed an Environmental Impact Report (EIR) to develop 40 acres of backland with the option to automate, however there is no estimated start/finish time (City of Los Angeles Harbor Department Planning and Economic Development Division, 2014). The other is the Yang Ming Terminal, which has completed an EIR to develop a new wharf and rail tracks that also includes an assessment of automation (City of Los Angeles Harbor Department Planning and Economic Development Division, 2014). There is no estimated start/finish time for this project. Lastly, there are also proposed terminal infrastructures for the Yusen Terminals Inc. and the Evergreen Terminal, but these terminals have not been associated with considering automation at the moment.

For most terminals, the decision to automate will not be made immediately, but is surely given serious consideration given the high labor costs at the Ports and the continuing trend of mega ships and growing environmental concerns, which emphasize the need for more goods-movement efficiency and more utilization of cleaner technology such as electric.

IMPACTS OF TERMINAL AUTOMATION

Similar to predicting future terminal automations, the potential impacts of container terminal automation are difficult to predict mainly because they depend on the type and mix of automation technologies a terminal

operator selects, as well as how the transition takes place. Despite the uncertainty of the aforementioned factors, limited information at hand can be used to make some statements regarding the impacts of terminal automation.

Efficiency

Handling efficiency of containers plays a key role in low-cost transportation and minimizing environmental impacts. Automated container terminals have proven effective in improving the utilization rate of equipment, reducing operating costs, and greatly improving terminal efficiency (Yan, Zhu, & He, 2014). This improved efficiency is especially evident as cargo volumes increase. However, as noted previously, full automation is not always required. Improved efficiency can also be achieved through limited automation and partnership with labor, or other non-automated strategies (City of Los Angeles Harbor Department Planning and Economic Development Division, 2014).

Capacity

According to pro-automation consulting firms, like CH2MHill, terminal automation increases a terminal's capacity to handle large ships (CH2MHILL, 2014). This is due to the increased efficiency and greater utilization of yard capacity that result from automation technology (CH2MHILL, 2014). In regard to the Middle Harbor Terminal, automation and other improvements in the redevelopment plan are expected to more than double its capacity to 3 million TEUs ("Port of Long Beach - Middle Harbor," n.d.). The completed automation and

upgrades at the TraPac Terminal increased its capacity to 2 million TEUs (City of Los Angeles Harbor Department Planning and Economic Development Division, 2014).

While it appears that terminal automation improves the automating terminal's capacity to handle large ships, according to the Economic Department it does not appear to expand the total volume of containers that POLA can handle in the long-term because the container cargo capacity of the port appears to be constrained by its berth capacity (City of Los Angeles Harbor Department Planning and Economic Development Division, 2014).

So it appears that automation can lead to an increased volume of cargo for a specific

terminal, but this may be cargo diverted from other internal terminals and may not result in an increased total volume of containers coming through the ports. Regardless of automation's role in increasing cargo volume for the region, cargo volumes through the ports are expected to continue a gradual increase that began after a low point in 2009 (Figure 4.11).

Environmental

Terminal automation results in improved air quality by decreasing emissions and greenhouse gases through utilizing more electricity as opposed to fossil fuels. The TraPac EIR demonstrated a 68 percent reduction in CO₂, 93 percent reduction in CH₄, and an 82 percent reduction in N₂O after transitioning from a conventional to an automated terminal (City of

Figure 4.11: Container Terminal Operations Flowchart

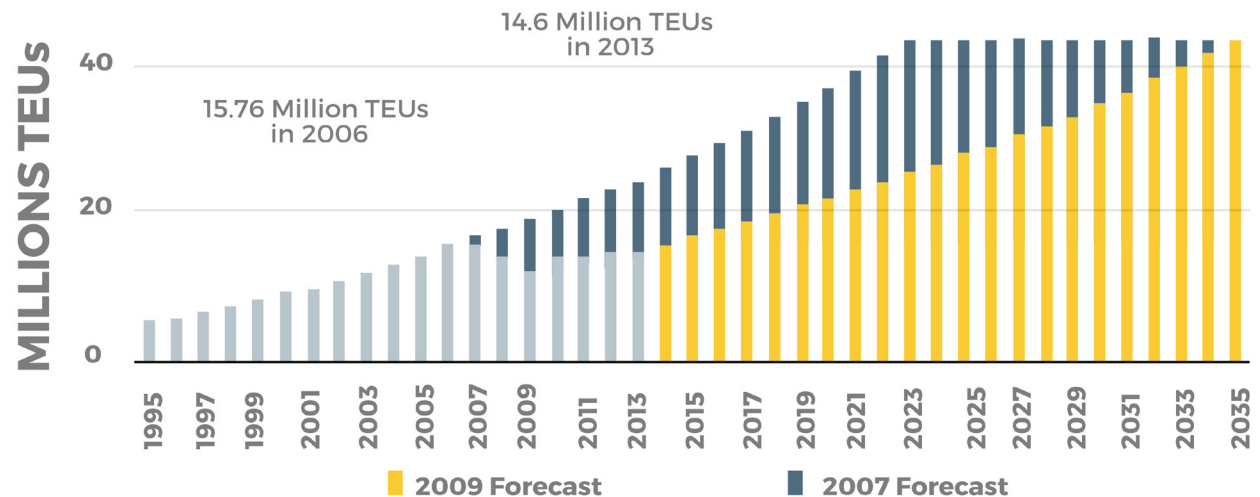

Source: The Port of Los Angeles, 2014

Los Angeles Harbor Department Planning and Economic Development Division, 2014). Other research has found that the implementation of terminal automation technology and gate reservation systems can also be effective in reducing emissions by lowering the overall truck idling time at terminals (Morais & Lord, 2006).

Financial

Terminal operators are responsible for investing in automation equipment, which is very expensive and a major concern among terminal operators. Additionally, the transition to automation can be unpredictable, as seen with the Middle Harbor redevelopment. Potential construction issues or ILWU interruptions could increase costs significantly and place the project in danger of becoming infeasible.

Conversely, on the operations side, terminal automation is expected to reduce operating costs (City of Los Angeles Harbor Department Planning and Economic Development Division, 2014). However, there are no known cost-savings examples since this requires detailed information on labor costs savings versus capital costs, which is not readily available information. Additionally, if automation reduced terminal costs and/or increases terminal efficiency, it can provide a competitive advantage to that terminal which also serves as a financial incentive.

Labor

The particulars of a terminal's transition to automation is influenced by complex and unpredictable negotiations between the ILWU

and terminal operators, which will undoubtedly alter how labor demand will be impacted. For example, terminal operators, like TraPac, can decide not to fully automate, which would lessen the potential job loss. There is also the potential for offsetting job losses by retraining ILWU workers in the repair and maintenance of the automated equipment if such training and opportunities are included in the negotiations. Furthermore, potential job losses would need to be weighed against the job losses that would occur if a port were to fall behind in competitiveness. According to the City of Los Angeles Harbor Department Planning and Economic Development Division, "If the cost reductions or efficiency gains through automating were great enough to give a competing port a competitive advantage over LA, then the resulting regional job losses due to cargo diversion could be much larger than the job losses from automation at the POLA." (City of Los Angeles Harbor Department Planning and Economic Development Division, 2014)

Aside from the unknowns, terminal automation clearly has significant positive and negative impacts on the longshore workforce. Firstly, terminal automation significantly increases worker safety by separating workers from the cargo handling section of the terminal, reducing worker accidents around equipment. According to Henk De Groot, the Chief Operating Officer for APM terminals in Rotterdam, safety is the key feature of an automated terminal (Mongelluzzo, 2015).

Additionally, there is the potential for technology

disruptions like container terminal automation to benefit the workforce in the long-run. The current trend in automation technology has the potential to create higher skill and higher wage jobs, and contribute to economic growth by expanding other logistics occupations like wholesale, transportation, and warehousing (Husing, 2016b; Petersen, 2015).

However, it is worth noting that these benefits to job quality, such as improved safety and wages, come at the direct expense of job losses and reduced demand for labor as a result of terminal automation technology. So the existing jobs within the terminal (i.e. on-dock employment) will be of higher wages and improved safety than previously, but that's due to the need for far fewer workers and the ability to work remotely. Since terminal automation inevitably leads to displacement of some segments of the workforce, it is important to manage the transition carefully, provide the opportunity for workers to receive training in new growing areas of work, and ensure there is a safety net for displaced workers who need it.

As previously mentioned, the amount of job reduction depends on the types of automation employed, the scale to which they are employed, and availability of workforce retraining and the opportunity for work in other logistics related areas (e.g. repairs & maintenance, shipping). As such, the Harbor Department's study on TraPac provides a useful example of potential impacts on labor. Since TraPac is only automating a portion of the terminal and keeping the remainder as a

traditional manned terminal, ILWU and TraPac representatives agree that automation is likely to result in a 40-50 percent reduction in the number of longshore jobs at the TraPac terminal (City of Los Angeles Harbor Department Planning and Economic Development Division, 2014).

Based on Pacific Maritime Association reporting on hours and wages, in 2011 the POLA-POLB complex employed the equivalent of approximately 9,000 full time longshore workers. The Harbor Department estimates that TraPac employed the equivalent of approximately 400 longshore workers, meaning a 40-50 percent job reduction equates to the equivalent of 160 to 200 lost jobs (City of Los Angeles Harbor Department Planning and Economic Development Division, 2014).

Since longshore jobs are dispatched from a hiring hall, the loss of jobs can be translated into a reduction in working hours across the total pool of longshore labor. Therefore, the City of Los Angeles Harbor Department equates a loss of 200 jobs to a loss of less than one hour of work per week or a 2.2 percent reduction in hours across the total pool of longshore labor (City of Los Angeles Harbor Department Planning and Economic Development Division, 2014). The Harbor Department notes that some of this job loss has been offset by hiring additional mechanics to service the automated equipment, but the report does not specify if displaced workers were the ones hired as additional mechanics or if workforce training was made available to impacted workers.

Additionally, there is a potential for a small portion of job losses to be offset by natural attrition. As previously noted, part of the ILWU accepting containerization was in exchange for increased wages for existing workers and buyouts for displaced ones. A similar type of negotiated settlement/compensation could benefit some workers, particularly those retirement or early retirement candidates. Reductions in job displacement will depend both on the adoption of these types of management practices and how much workers are compensated.

Lastly, there is the likelihood that container terminal automation would reduce the price of shipping and subsequently increase shipping volumes and port competitiveness, which could potentially further offset job losses by growing employment opportunities in other terminals and logistic related employment (Petersen, 2015).

From a macro perspective, the reduction of TraPac's on-dock employment from terminal automation does not seem as bleak when it is viewed as a loss of one hour a week across the whole labor pool rather than a loss of 200 jobs, and also in part because of the resulting growth in other related areas of work. Considering these factors, it is unclear how large a safety net should be provided for displaced workers or even how many workers actually get displaced in reality, since the job reduction could be spread across the total pooled labor force and result in fewer hours for many workers and not necessarily full job losses. Additionally, because of the

unknowns around the displaced segment of the workforce, such as demographics, background, skills, and education, it is still unclear what the appropriate safety net should entail.

If more terminals decide to automate, the job losses will become more significant. There will be a larger number of people who become displaced or underemployed and may require support in the form of re-training. Given the median wage and strong benefits of these displaced positions, these individuals may struggle with maintaining the standard of living ILWU employment has afforded them. If displaced workers are not able to find equivalent paying employment, there is the possibility that these workers risk becoming a low-income household, which would further the current hollowing of the middle class.

Broader Community

The resulting job losses from terminal automation are significant to local communities since these are middle wage jobs with relatively low skill requirements. Unfortunately, San Pedro and Wilmington never had strong employment ties to the port to begin with, which is a larger problem in itself. According to ILWU data on the geographical distribution of its longshore workers, approximately 27.7 percent of Local 13 workers live in San Pedro and 9.8 percent live in Wilmington (City of Los Angeles Harbor Department Planning and Economic Development Division, 2014). While the port is not the primary source of employment for these communities, they still provide a feasible path to middle income employment and pay

significantly more than the median household incomes in these communities. Barriers to union membership and work hours for low-income communities, particularly impacted communities like Wilmington and San Pedro, should be explored with the goal of increasing inclusion of impacted communities and increasing union diversity in terms of class, gender, and race.

On a larger scale, the volume of incoming cargo into the ports complex is expected to increase in the coming years. As previously mentioned, while terminal automation increases an individual terminal's capacity to handle large ships with higher volumes of cargo, it is still unclear the exact impact on the total volume of containers coming through the port as a whole. Nonetheless, the steadily increasing level of cargo volume into the region will impact communities across the region by increasing logistics activities and expanding growth in logistics occupations like wholesale, transportation, and warehousing.

For example, in the Inland Empire, logistics operations (wholesale, warehousing, transportation) had the largest share of growth in the moderate paying blue collar or technical sectors from 2011-2015 (Husing, 2016a). This is directly due to the recent growth of imports at the POLA-POLB complex and the rapid expansion of fulfillment centers to process goods for delivery that were purchased online (Husing, 2016a). Since these trends are expected to continue, growth in these logistics areas is also expected to continue. It is important to recognize that as

logistics activities continue to grow, the existing negative externalities of the goods movement system will also magnify if cleaner technologies and more inclusive and equitable planning processes are not adopted.

In a broader context, terminal automation is a part of the larger trend of automation technology that is becoming more utilized throughout many industries. As automation technology becomes implemented in other logistics occupations like transportation and warehousing, a similar trend of displacing a segment of the workforce is expected. Displaced occupations are expected to be entry-level employment (Husing, 2016b).

Unlike displaced longshore workers, these occupations do not have the benefit of union representation to negotiate financial compensation, training support, or support securing employment in other occupations. Additionally, these are low wage occupations and misclassification issues can actually result in workers earning below minimum wage. Considering this history of low wages and lack of union representation, workers of these occupations are particularly vulnerable during the transition to automation as opposed to longshore workers.

Lastly, as automation technology displaces entry-level occupations, there will be an increase in the skills and education necessary to secure middle-income occupations in this sector. New and growing occupations in logistics will prioritize knowledge of Information Technology

(IT) and/or an education background in science, technology, engineering, or math (STEM). This demand for higher level of skills creates a skills barrier for marginally educated workers in entering these positions. Considering that marginally educated workers have always struggled to gain access to the middle class and the trend of losing middle-income longshore positions that are relatively low skill, there is an even greater importance to eliminate the skills gap for these workers and provide workforce development opportunities for middle income employment.

ENVISIONING SUSTAINABILITY, EQUITY, AND COMMUNITY POWER

In order to infuse more social equity into the terminal automation process, a strong safety net for displaced longshore workers who require support in securing other employment should be established. Since ILWU has bargaining power with terminal operators, they are already in a position to advocate for such supports. Historically, ILWU has accepted reduced longshore demand for financial compensation, or buy outs for displaced workers and higher wages for existing workers. However, it is not enough to secure higher wages for existing workers since these will be limited positions and are expected to continue to decrease as automation continues. More importantly, the workers who are most likely to require support due to marginally lower education/skills that may act as barriers to broader employment opportunities are not the workers who will

secure the higher paying jobs that are left over. To address this inequality, re-training and/or education and support securing a different occupation should be made available to all workers who become displaced or underemployed as a result of automation.

Additionally, it is important to address the social equity concerns within the larger picture of longshore employment. Specifically, the impacted communities like Wilmington and San Pedro should be represented in greater numbers within the longshore workforce. It is important that workers from these communities that disproportionately bear the burden of the goods movement system not only have equal access to longshore employment but are prioritized for these opportunities. Furthermore, it is important that the longshore employment process is free from class, gender, and racial discrimination so that traditionally marginalized groups also have equal access to these well paying occupations.

To instill more sustainability into the terminal automation process, technology upgrades should employ the cleanest technology available. Ideally, the adoption of cleaner technologies will spread beyond the ports and into the shipping, transportation, and warehousing sectors. Furthermore, the transition to automation also provides the opportunity to promote “green jobs” as an alternative sector for displaced longshore workers. Rather than simply re-training displaced workers for other occupations in logistics, workers could be trained and provided an avenue to employment within the green jobs sector, which could aid in expanding this sector.

Lastly, in order to foster more social equity into the larger trend of automation technology, the skills barrier for marginally educated workers in securing middle income logistics occupations must be addressed. As other logistics occupations like transportation and warehousing undergo the automation transition, it is important that marginally educated workers, in particular from impacted communities, have access and are competitive for these changing middle-income occupations in logistics. To keep up with the skills demand for this field, impacted communities where transportation and warehousing activities are concentrated should be provided with workforce development programming that provides IT, or other appropriate, training and a direct avenue to employment within these occupations.

As with the longshore workforce, the logistics workforce should provide equal opportunity to all workers regardless of class, gender, or race, and should also prioritize hiring from marginalized communities. In a larger context, all employers operating within a Capitalist framework should provide more equitable labor practices such as adequate worker safety, strong employment benefits, and less wage inequality.

In order to eliminate the skills barrier for vulnerable communities, it is equally important to prepare future generations for middle-income employment in addition to providing workforce development for adults. Increasing exposure to and engagement in STEM learning outside of formal classroom settings is increasingly viewed as key to motivating more young people

to STEM studies, and to addressing the social equity gaps between high and low resourced families and communities (Silver-Pacuilla, n.d.). As the age of automation continues, it becomes increasingly important to address the skills barrier for marginally educated communities so that they too have the opportunity to be competitive in a growing sector that provides middle income employment.

STRATEGIC INTERVENTIONS

WORKFORCE DEVELOPMENT PROGRAMMING

Workforce development programming can assist all workers who become displaced or underemployed as a result of automation gain the necessary skills to be competitive for middle income logistics occupations. Workforce development programming could also establish relationships with private industry employers to offer a direct line to employment for individuals who complete the necessary training. While the capacity of the America’s Jobs Center (AJC) system to support an influx of adults is unclear, the existing structure could theoretically be utilized to support displaced longshore workers, truckers, and warehouse workers. AJC is implemented through the Department of Labor’s workforce development policy Workforce Innovation and Opportunity Act (WIOA). Additionally, new public-private partnerships could be created to provide a specialized training and employment pipeline for displaced workers from logistics occupations. The public-private partnership model of programming is becoming more popular and is increasingly seen as an

effective strategy, since it requires investment from employers and provides insight and training that is tailored to meet the specific needs of that employer. Lastly, specialized trainings and employment pathways can be established and provided at the community college level.

Expand SEED initiative

SEED (STEM, Energy, and Economic Development) initiative is supported by the Departments of Housing and Urban Development (HUD), Education (ED), and Energy (DOE). The goal of this program is to expose low-resourced communities, from preschoolers to adults, to STEM learning as a means to lessen equality between low-resourced and high-resourced communities. The program seeks to motivate youth to engage in STEM studies, which is a key factor to entering middle-income logistics occupations among others. SEED is currently implemented in various public housing authorities (PHAs) nationwide that display an average household income of \$11,109 (Silver-Pacuilla, n.d.). PHAs have documented 138 STEM-related activities and training that have reached over 1,200 residents. Examples include: water conservation work in partnership with a water management district/entity; public library programming that provides broadband equipment and tables and digital literacy training to youth in after-school programs; STEM Week at local schools, museums, and girl scouts; and training opportunities that link residents with employment opportunities in targeted industries like green and energy efficiency.

REDUCING EMISSIONS FROM HEAVY-DUTY DRAYAGE TRUCKS

BACKGROUND

Air quality at the ports of Los Angeles and Long Beach consistently ranks among the worst in the nation, largely due to emissions from the heavy-duty drayage trucks delivering and retrieving goods in the region. Pervasive community health issues are a direct result of this poor air quality. The largest sources of emissions are from the ocean-going vessels, however, neither POLB nor POLA have the authority to monitor or enforce emissions standards for international vessels. Particulates from the drayage trucks, which primarily run on diesel fuels, are the second largest source of emissions (Port of Los Angeles, 2014). Integrating cleaner trucks with the other transportation and technology improvements identified in this section ensures that increased efficiency does not lead to cumulative increases in harmful emissions.

Zero- and near-zero emissions fuels and technologies present opportunities to drastically reduce the environmental and health-related harms caused by these emissions. This section offers an overview of the most feasible and timely alternatives. A strategy to implement a new clean trucks program, referred to hereafter as Clean Trucks 2.0, requires leveraging existing policies and funding resources to create a more

sustainable goods movement system for the Ports.

Major retailers such as Amazon, Walmart, and Costco have begun to address truck emissions by investing in new technologies, such as the Walmart Advanced Vehicle Experience, a prototype that combines aerodynamics and electrification (Walmart, 2016). These investments are a positive step in the right direction, but mandatory policies and incentives for cleaner drayage trucks are necessary to reach the entire trucking sector. Clean fleet policies must also be accompanied by a shift in the current labor structure of the port trucking industry. This will ultimately determine the effectiveness of a system-wide program to mandate zero and near-zero emissions trucks.

The Los Angeles Alliance for a New Economy (LAANE) has been a critical force in helping to bridge community and labor groups to demand better working conditions. Their efforts led to nearly forty organizations uniting to form the Coalition for Clean and Safe Ports (CCSP) in 2006, which became instrumental in building trust and sharing key concerns among members about the state of conditions in the trucking industry (Durrum, 2013). The CCSP helped craft the Clean Trucks Program, which required that only low-emissions trucks enter the ports.

The Ports adopted the Clean Trucks Program in 2008, which drastically reduced emissions; however, the increased volume of goods

movement has outpaced those reductions. The Clean Trucks Program became a core component of the Clean Air Action Plan (CAAP), a voluntary agreement launched by the Ports in 2006. The Clean Trucks Program involved a three-step phase-out of the most polluting trucks, banning all pre-1989 trucks from entering the port in 2008 and all pre-1993 trucks and non-retrofitted pre-2003 trucks by 2010. All trucks that did not meet the 2007 Federal Clean Truck Emissions Standards were banned from the ports by 2012. The phase-out policy was driven in large part by local community pressure for the Ports to address their environmental and health concerns prior to further port expansion (Thornton, 2008). New and retrofitted trucks were subsidized by federal, state, and regional grants.

The overarching Clean Air Action Plan has been the most comprehensive initiative to reduce particulate emissions since its release in 2006. The CAAP primarily targets the pollutants: Particulate Matter 2.5 (PM 2.5), Diesel Particulate Matter (DPM), Nitrous Oxide (NOx), and sulfur oxide (SOx) because they have the strongest ties to respiratory issues: “PM emissions from diesel engines contribute to 3,500 premature deaths and 250 cases of lung cancer every year in California. NOx reduces lung function and increases the risk of infection by weakening the immune system” (Petrilla et al., 2009).

The combination of a progressive ban on the old technologies with subsidies to help cover the cost of the new, cleaner trucks led to

reductions exceeding 85 percent for particulate matter, 50 percent for nitrogen oxides, and 95 percent for sulfur oxides within five years of implementation (Clean Air Action Plan, 2016). New trucks that met the requirements of the Clean Trucks Program cost between \$93,000 to more than \$190,000 (Petrilla et al., 2009). Truck subsidies were distributed through a range of programs, including the San Pedro Bay Port Liquefied Natural Gas Program, the SCAQMD/ Prop 1 Clean Truck Program, the San Pedro Bay Ports Truck Replacement Program, and the Port of Los Angeles 20k Incentive Program (LAANE, 2012).

Several of these sources weakened following the release of the plan due to a freeze on Proposition 1B funds earmarked for transportation projects. Budget shortfalls and the removal of the \$35 TEU fee also weakened funding sources due to unpopularity and fear of competition from other fee-free ports (Yoh, 2016). In addition, the major issue of trucking companies misclassifying truck drivers as IOOs rather than employees severely undermined the success of the Clean Trucks Program as well as the subsidy allocation process.

EXISTING CONDITIONS AND TRENDS

Port officials, community groups, and politicians at the local, regional, state and federal level have all taken steps to address pollution at the Ports. These stakeholders have allocated

significant amounts of funding to develop zero and near-zero emissions technologies. There is debate surrounding the best alternative, and no technology is perfect, however, introducing interventions to deploy existing clean technologies are pivotal to improving air quality near the Ports. Existing and proposed technologies include compressed natural gas, renewable natural gas (which is not a fossil fuel), battery electric trucks, and fuel cell technologies.

The current status of these technologies range from existing, to ready for deployment, to the very early pilot stages. One thing that is certain is that electric trucks will not be available for wide scale commercial deployment at the Ports within the next ten to twenty years, and a narrow focus on this solution will not help bring the South Coast Air Basin under attainment to meet the Environmental Protection Agency’s air quality standards by 2032. Resources should be allocated to more readily available technologies that can drastically lower emissions and improve air quality within the next five years if implemented immediately. According to Gladstein, Neandross & Associates, near-zero-emission natural gas engines that use renewable natural gas offer a proven and affordable near-term strategy to achieve major emissions reductions (Gladstein, Neandross & Associates, 2016).

The major challenges that lie ahead are development of the renewable natural gas market, united political support, adequate funding, and the continued misclassification of truck drivers. If these challenges can be

overcome through a united community and political support system, there is enormous potential to improve air quality and thus enhance the lives of communities and workers who are most affected by the pollution surrounding the Ports.

TRUCKER MISCLASSIFICATION AND THE CLEAN TRUCKS PROGRAM

Despite overall success from an environmental standpoint, the Clean Trucks Program led to unintended economic consequences for the majority of truck drivers who are misclassified as IOOs. Trucking companies, also known as licensed motor carriers (LMCs), consistently misclassify drivers as IOOs in order to avoid state and national labor and employment law protections. Following the adoption of the Clean Trucks Program, LMCs had an even stronger interest to uphold the IOO classification to in order to avoid financial liability of purchasing new trucks and paying for vehicle operations and maintenance (Bensman, 2009).

In recognition of these misclassification issues, the CTP required truck firms to directly own and operate the new vehicles instead of subcontracting to IOOs as a means to prevent capital and maintenance costs from falling onto the shoulder's of the already underpaid IOOs. The Port of Los Angeles and the Port of Long Beach diverged on their handling of this issue. The Port of Long Beach caved to industry pressure from the trucking companies and passed a program that did not require LMCs to hire their drivers as employees (Durrum, 2013). The Port of Los

Angeles attempted to uphold this stipulation to protect drivers, but a lawsuit brought forth by the American Trucking Association thwarted these efforts and resulted in a court order that prohibited the Ports from setting any trucking standards requiring employment. This ultimately left IOOs misclassified and transferred these costs to the independent drivers, an enormous financial burden (LAANE, The Big Rig, 2014). Progress to rectify the misclassification issue has been slow but the IOOs, led by The Teamsters trucking union, have won several lawsuits in the past few years against trucking companies illegally classifying drivers as independent contractors under labor law rather than employees (Gruenberg, 2015). It is time to replace the current fleet of trucks servicing the Ports again, but it important that the next implementation program include sufficient funding and protective mechanisms for truck drivers in order to avoid similar unintended consequences.

FUEL & TECHNOLOGY ALTERNATIVES

Due to continued growth in goods movement at the Ports, fuel consumption within the heavy duty truck sector is rising rapidly. Research shows an anticipated national 23 percent increase in fuel consumption (primarily diesel) in this segment from 2009 to 2020 (Stanton, 2013). To prevent this rise in heavily-polluting truck fuels, alternative options have emerged. These alternatives to diesel fuel include: compressed natural gas, liquefied natural gas, biodiesel, renewable natural gas, electric trucks, and fuel cell-powered engines. A fuel carbon

intensity score for heavy-duty trucks developed by the California Air Resources Board's GREET 2.0 model (**Figure 4.12**) provides a comparison of the life-cycle carbon intensities for the following fuels, with diesel scoring a baseline carbon intensity of 102 (CARB, 2015). The model estimates direct life cycle emissions from the production, transport, and use of transportation fuels. GREET stands for "Greenhouse Gases, Regulated Emissions, and Energy Use in Transportation."

Natural Gas

Wide Scale adoption of compressed natural gas (CNG) and liquefied natural gas (LNG) has taken place since the Clean Trucks Program was adopted in 2008. Both emit significantly lower levels of diesel particulates, NOx, SOx, and carbon emissions; however a lifecycle comparison reveals less promising results. Despite an average 80 percent reduction in ozone-forming tailpipe emissions from natural gas compared to gasoline-powered vehicles (Department of Energy, 2015), there are significant emissions involved in the extraction, production, storage, and transportation of these fuels (Stanton, 2013). On average, natural gas emits 6-11 percent lower levels of greenhouse gas emissions than gasoline throughout the fuel life cycle (Department of Energy, 2015).

Liquefied natural gas requires high amounts of energy to liquefy and cool the gas, and the cost for LNG infrastructure is higher than that of CNG (Beer et. al, 2002). The use of CNG and LNG following the Clean Trucks Program has helped

Figure 4.12: Carbon Intensities of Heavy-Duty Trucks

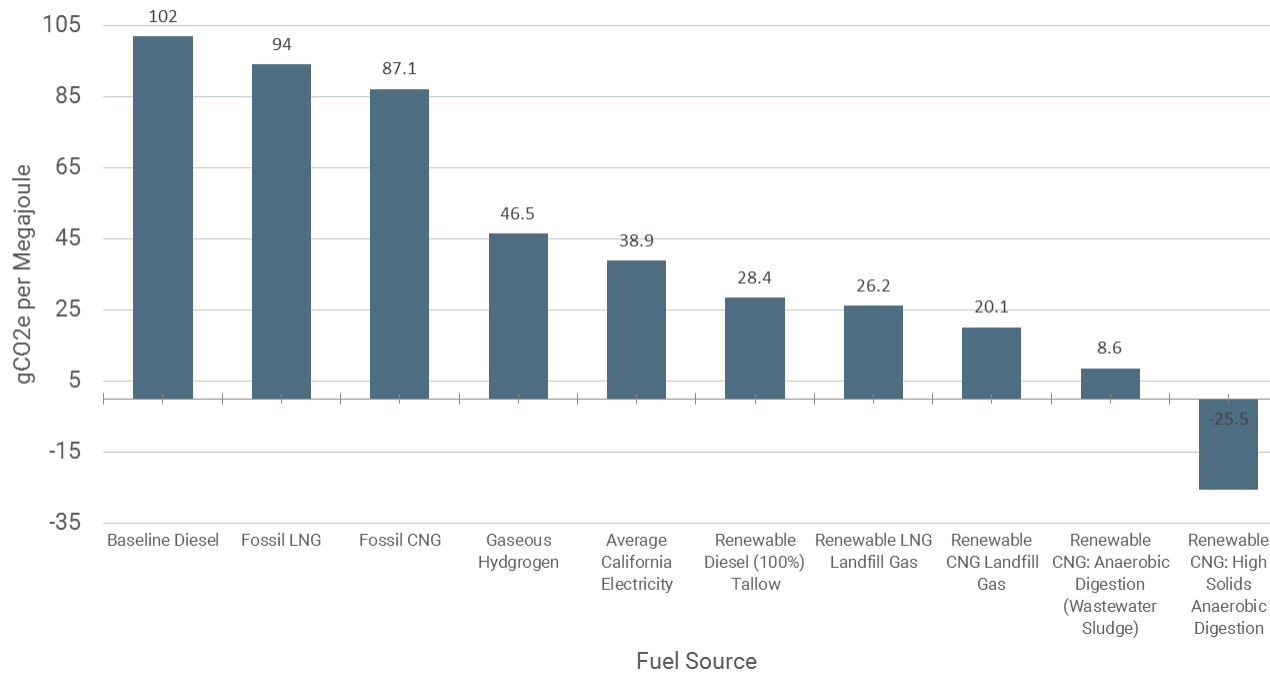

Source: Gladstein Neandross & Associates, *Gamechanger White Paper*, 2016.

improve air quality at the ports considerably, but the emissions to extract, store, and deliver the fuel produce negative environmental and health impacts in other communities. CNG has a carbon intensity score of 87.1 and LNG scores 94 compared to the diesel baseline of 102.

Biodiesel

Biodiesel is a fuel made from renewable biological sources such as vegetable oils, animal fats, and recycled cooking oils. It can be used in a diesel engine without modification as either pure biofuel (B100), or as a blend with petroleum diesel, known as B35 for 35 percent biodiesel or B20 for 20 percent biodiesel, with traditional diesel making up the difference (Wange et al, 2000). Biodiesel is typically renewable and emits very low levels of particulate matter and carbon emissions, but produces comparable levels of nitrous oxides to traditional diesel fuel. Since biodiesel is comprised of mostly organic materials containing nitrogen, as the concentration of biological sources increases,

so does the level of NOx. Biodiesel made from 100 percent tallow, an animal fat, has a carbon intensity score of 28.4, which is significantly lower than CNG, LNG, and diesel.

Renewable Natural Gas

Renewable natural gas (RNG), also known as biogas, is chemically identical to fossil natural gas; however it is 100 percent renewable and generates nearly zero greenhouse gas emissions and particulates. The combination of RNG and a new near zero-emission natural gas engine (known as RNG + NGE in this report) developed by Cummins Westport can reduce NOx emissions to 90 percent below the current CARB and EPA emissions standards, an unprecedented drop (Gladstein, Neandross & Associates, 2016). The existing 8.9L natural gas engine can be used in class 8 short-haul trucks, and deployment is beginning now in 2016. The larger 11.9L engine, which is compatible with class 8 long-haul trucks used for longer range deliveries will be ready for deployment in 2018 (GNA, 2016). A Clean Trucks 2.0 strategy to deploy these engines should start as soon as possible to pave the way for deployment across all trucks once the technology is ready.

Sources of RNG include landfill gas, wastewater sludge, food waste, and animal waste. The production and consumption of RNG reduces carbon emissions by 88 percent or more compared to diesel (Energy Vision, n.d.). RNG produced from food waste via high solids anaerobic digestion is the most sustainable option, with a negative carbon intensity score of

-25.5, followed by wastewater sludge anaerobic digestion, renewable CNG from landfill gas, and renewable LNG landfill gas (CARB, 2015).

Since landfills are the third-largest sources of human-related methane emissions in the country, capturing this gas and converting it to transportation fuel has the benefit of both preventing these emissions from traditional methane flares and eliminating emissions from diesel fuel. The digestion process for landfill biogas takes place in the ground rather than an anaerobic digester.

RNG from wastewater sludge and food waste is produced through the naturally-occurring process of anaerobic digestion. When organic waste is confined in large air-tight vessels, it takes approximately one month to break down into biogas (Energy Vision, n.d.), which can then be processed to a higher purity standard that is chemically similar to conventional natural gas (Department of Energy, 2016).

As of March 2016, California has 78 operational landfill gas projects and an additional 26 candidate landfills, which are landfills that have the potential to be converted into biogas-producing operations (U.S. EPA, 2016). The state of California now uses four times the amount of RNG as Sweden and produces more RNG than any country in the world (Neandross, 2016).

While our numbers are more “back of the envelope” at this point, we believe that California has the potential resource base to produce

renewable natural gas from various sources that can displace all diesel fuel consumption in the state. Of course, achieving such goals will certainly require that we have the right policy mechanisms in place (Neandross, 2016).

Utilizing these existing supplies of renewable natural gas to fuel heavy duty trucks can help build a more robust RNG market, eliminate harmful emissions, and help reach regional and state air quality targets.

Electric trucks

Electric trucks powered by grid electricity meet the California Air Resources Board's standard for zero emissions (no direct-vehicle emissions), however there are emissions related to the electricity production. California's renewable fuel portfolio is relatively high compared to other states, but the electric grid is still powered by approximately 60 percent non-renewable sources (California Energy Commission, 2015). Other factors inhibiting the near-term viability of electric trucks are high initial capital cost, limited freight capacity due to battery size and weight, reliability issues for many existing products in the market, and limited charging station infrastructure (Neandross, 2016).

The capital cost of electric trucks is between \$350,000-\$500,000, with an additional \$30,000-\$50,000 cost for a charger that can charge four trucks at a time (BYD, 2015), compared to an average cost of \$160,000 for RNG trucks with the natural gas engine (GNA, 2015). Thus, funding for electric trucks would yield far less environmental

and health benefits than RNG trucks, in addition to increasing the financial burden for both trucking companies and IOOs. Energy fuel researchers reveal that an investment in natural gas trucks operating on 100 percent RNG from landfill gas would provide approximately five to fourteen times the greenhouse gas reductions as battery-electric trucks plugged into California's electric grid (GNA, 2016).

Several companies, including BYD Motors, have been developing long range electric heavy duty drayage trucks as part of the California Air Resources Board's 2015 Drayage Solicitation project. The most recent battery released has a 188 kWh capacity and an extended driving range of 92 miles (CARB, 2016), but this range does not meet all drayage trip distances. Despite funding from CARB and numerous other entities for electric truck projects, there is consensus among major stakeholders that wide-scale deployment of electric trucks over the next 15 years would require technology development and costs that far exceed technology and costs to deploy low-NOx trucks (GNA, 2016).

The recent draft of the California Sustainable Freight Action Plan, a collaborative effort between the California State Transportation Agency, California Environmental Protection Agency, California Air Resources Board, and other agencies, states that development of “renewable fuels can provided nearer term emissions reductions in applications where zero emissions are not yet feasible” (California Department of Transportation, et. al., 2016).

Electricity from California's grid has a carbon intensity score of 38.9.

There are 300 medium-duty battery electric trucks in service throughout California, and it is possible that the technology for heavy-duty electric trucks will be widely available with access to an even cleaner grid in the future (CADOT et al. 2016). Considering the state of the technologies, it is crucial that policy-makers, community organizations, and other stakeholders consider the full spectrum of possibilities when allocating funds for research and development of near-zero emissions and zero-emissions heavy-duty trucks.

Due to the lack of market and technological maturity at the current time - and likely for the next decade or so - an unequivocal reliance on heavy-duty electric trucks is equivalent to accepting a diesel truck status quo for the next 10 to 20 years, or maybe more. We believe this presents significant and serious social equity issues in the communities that are seeking immediate air quality relief from the single largest source of dangerous emissions in their neighborhoods - heavy duty diesel trucks (Neandross, Interview, 2016).

Hydrogen Fuel Cell

Fuel cell electric vehicle technology has the capability to completely eliminate tailpipe emissions offering a true path to zero emissions compared to a conventional fossil-fueled truck (ARB, 2015). The technology is still in the early stages of development, though ARB believes that fuel cell technology will ultimately help

California reach its air quality and petroleum reduction goals (ARB, 2015). Fuel cell electric vehicles have a fuel cell system that generates electricity to propel the vehicle. The hydrogen fuel produces electricity, heat and water vapor rather than harmful pollutants. A heavy-duty fuel cell electric truck will likely be a hybridization design of a fuel cell paired with a battery storage system (ARB, 2015).

This option has extremely low carbon fuel intensity with a very high drive train efficiency (GNA, 2016). The anticipated timeframe is 10 to 20 years for commercial viability (GNA, 2016). The main hindrances to earlier deployment are high vehicle cost, cost and access to hydrogen fuel, and the need for more frequent vehicle fueling (CARB, 2015). Hydrogen is currently much more expensive than diesel fuel, but costs are expected to decrease as production volume increases (CARB, 2015). The California Energy Commission has provided \$20 million per year to fund hydrogen fueling stations in order to accelerate market development. As of November 2015, California had 13 operating hydrogen stations, with 51 stations anticipated by late 2016 (CARB, 2015).

ENVISIONING SUSTAINABILITY, EQUITY, AND COMMUNITY POWER

AIR QUALITY

Despite dramatic improvements in air quality over the past few decades, the South Coast Air Basin consistently fails to meet air quality

“Due to the lack of market and technological maturity at the current time - and likely for the next decade or so - an unequivocal reliance on heavy-duty electric trucks is equivalent to accepting a diesel truck status quo for the next 10 to 20 years, or maybe more.

We believe this presents significant and serious social equity issues in the communities that are seeking immediate air quality relief from the single largest source of dangerous emissions in their neighborhoods - heavy duty diesel trucks

ERIC NEANDROSS, 2016

standards set by the U.S. Environmental Protection Agency (EPA) and managed by the South Coast Air Quality Management District (SCAQMD). The American Lung Association's 2016 State of the Air Report ranks the Los Angeles-Long Beach metropolitan area as the worst ozone pollution in the country, as it has for fifteen of the past sixteen years (American Lung Association, 2016). The region ranks number one (the worst) for high ozone days out of 197 metropolitan areas, number nine for 24-hour particle pollution out of 94 metropolitan areas, and number four for annual particle pollution out of 171 metropolitan areas (American Lung Association, 2016).

The SCAG Regional Transportation Plan notes that, "while Southern California is a leader in reducing emissions, and ambient levels of air pollutants are improving, the SCAG region continues to have the worst air quality in the nation, and air pollution still causes thousands of premature deaths every year, as well as other serious adverse health effects. SCAQMD estimates the monetary cost of air pollution in Southern California to be at least \$14.6 billion annually" (SCAG, 2016). Most emissions sources, including cars and factories, are already controlled by over 90 percent, which means that attainment of air quality standards will require broad deployment of zero- and near-zero emission technologies in the 2023–2035 time frame (SCAG, 2016).

The South Coast Air Basin has a deadline to reduce ozone concentrations to 80 parts per billion (ppb) by 2023 and down to 75 ppb by 2031

under the 2008 eight-hour ozone standards set by the U.S. Environmental Protection Agency. Current ozone levels in the Los Angeles region are around 110 ppb (South Coast Air Quality Management District, 2014). Ozone is formed when NOx reacts with volatile organic compounds under heat and sunlight (U.S. EPA, 2016). According to the U.S. EPA, the health impacts of ozone include: respiratory harms such as asthma and inflammation; early death due to long- and short-term exposure; cardiovascular harm such as heart attacks, stroke, heart disease; harm to the central nervous system; and reproductive and developmental harm (U.S. EPA, 2013).

In addition to mandatory ozone reductions, NOx emissions must be reduced 65 percent by 2023 and 75 percent (beyond projected 2023 emissions) by 2032 in order to meet federal ozone standards, with additional attainment deadlines are in effect for PM 2.5 (SCAG, 2016). GNA anticipates that their proposed natural gas engines with RNG will reduce NOx emissions by 90 percent (GNA, 2016).

Exposure to NOx can cause similar health impacts to ozone, including increased risk of asthma, particularly for children and the elderly. NOx reacts with small particles that can penetrate deep into the lungs. This can cause emphysema and bronchitis, and can aggravate existing heart disease, leading to increased hospital admissions and premature death (U.S. EPA, 2016). Heavy-duty trucks at the Ports account for 24 percent of total NOx emissions, representing a significant opportunity for improvement (Port

of Los Angeles, 2014). The trucks account for 41 percent of total greenhouse gas emissions in the region (Port of Los Angeles, 2014), indicating the serious climate change impacts that can also be addressed through a new clean trucks program.

Many programs and policies are in place to address the air quality issues pervading the South Coast region. As results from the first Clean Trucks Program showed, replacing heavy-duty trucks with less-polluting trucks represents a low-hanging fruit that can lead to dramatic air quality improvements.

TRUCKER MISCLASSIFICATION STATUS

Despite a recent shift in the legal landscape due to million-dollar lawsuits against trucking companies for wage claims, approximately 90 percent of truck drivers are still classified as independent owner operators rather than employees (Santamaria, 2016). The IOOs do not have access to the appropriate employee benefits and remain vulnerable to abuse under a subsequent Clean Trucks Program. The American Trucking Association lawsuit fought the Clean Trucks Program all the way to the Supreme Court, where the Court struck down most of the CTP provision by claiming that the program preempted federal law. The only two provisions standing pertain to financial capacity and truck maintenance (Santamaria, 2016).

Several trucking companies have gone bankrupt fighting misclassification issues. The trucking industry operates at a very thin profit margin, leaving little room to afford the costs of new or upgraded trucks, however they are better

positioned to do so than the IOOs. A much larger piece of this puzzle is to figure out how to pass along the costs further down the supply chain so the burden of financing new trucks does not fall onto the weakest sector of the goods movement system (Personal Interview, 2016).

EXISTING POLICIES, INCENTIVES, AND FUNDING SOURCES

Federal, state, and regional entities have recognized the need for cleaner trucks to replace the existing fleets at the ports. There are numerous federal and state programs that provide incentives and mandatory policies fund allocation for research and development, and eventually deployment, of near-zero and zero-emissions trucks. Some of these programs include the U.S. EPA Clean Diesel Program, the California Sustainable Freight Action Plan and SCAG's Regional Transportation Plan/Sustainable Communities Strategy (RTP/SCS). Currently, there is competition for funding between those supporting electric trucks, the most politically appealing, and other alternatives including RNG trucks. Most policies do not specifically advocate for a certain type of alternative technology, rather they state the need for zero-emissions trucks. Officials will need to come to a consensus to support RNG trucks in addition to existing electric truck pilot projects in order to help develop the RNG market leading up to the release of the 11.9L Siemens natural gas engine. An overview of federal, state, and regional policies supporting a more sustainable freight system and specifically near-zero emissions trucks is below.

FEDERAL *Fast Act*

At the federal level, President Obama signed into law the Fixing America's Surface Transportation (FAST) Act in 2015 to provide long-term funding for surface transportation infrastructure planning and investment (U.S. Department of Transportation, 2016). The FAST Act authorizes \$305 billion from 2016 to 2020 for transportation projects, including a number of provisions focused on ensuring a safe, efficient, and reliable movement of freight (U.S. Department of Transportation, 2016). The FAST Act also establishes a National Multimodal Freight Policy that includes national goals to guide decision-making, and requires the Development of a National Freight Strategic Plan to implement the goals of the new National Multimodal Freight Policy (U.S. Department of Transportation, 2016).

Diesel Emissions Reduction Program

The U.S. EPA introduced a national Diesel Emissions Reduction Program and began awarding clean diesel grants in 2008 under the Diesel Emissions Reduction Act (DERA). Congress created this grant program as part of the Energy Policy Act of 2005 to reduce diesel exhaust from these older engines (U.S. EPA, 2016). EPA's National Clean Diesel Campaign within the Office of Transportation and Air Quality administers the DERA grants, which have led to enormous environmental and health benefits. From 2009-2013, the DERA program invested \$520 million to replace and retrofit nearly 60,000 truck engines (U.S. EPA, 2016). These changes are expected to save approximately 312,500 tons of NOx emissions and close to 5 million

tons of carbon dioxide over the lifetime of the engines (U.S. EPA, 2016). EPA awarded 642 grants throughout the country over the course of the program from FY 2008 to 2013.

The DERA requires EPA to provide 30 percent of the annual appropriation to states to implement their own clean diesel programs (U.S. EPA, 2016). EPA conducted an analysis of the state grant program and found that state clean diesel projects were more cost effective if they followed DERA national program requirements.

Phase 2 Greenhouse Gas Emissions and Fuel Efficiency Standards for Medium-Heavy Duty Trucks

In 2015, the U.S. Environmental Protection Agency (EPA) and the Department of Transportation's National Highway Traffic Safety Administration (NHTSA) jointly proposed a national program to establish the next phase of greenhouse gas emissions and fuel efficiency standards for medium- and heavy-duty vehicles (U.S. EPA, 2015). The fully phased-in standards would achieve up to 24 percent lower CO2 emissions and fuel consumption compared to the earlier Phase 1 standards (U.S. EPA, 2015). The RNG + NGE trucks would help achieve this enhanced standard.

Low Carbon Fuel Standard

Executive Order S-1-07, the Low Carbon Fuel Standard (LCFS) was issued in 2007 under the AB 32 Scoping Plan. The LCFS was developed to reduce the carbon intensity of transportation fuel by at least 10 percent below 1990 levels by 2020. The program works in tandem with the statewide Cap-and-Trade program to incentivize

the adoption of cleaner fuels through a market-based system. Petroleum and biofuel providers are required to participate and clean fuel providers may opt in to the program. Fuels that have lower carbon intensities than 1990 levels generate credits that can be traded. (Petrilla, John, Sato, Kenji, & Sywak, Andy, 2009)

STATE EXECUTIVE ORDER B-32-15

California continues to be a leader with some of the most ambitious new standards for less-polluting drayage trucks. Governor Jerry Brown signed Executive Order B-32-15 in July, 2015, which directs the California State Transportation Agency, the California Environmental Protection Agency, and others to improve freight efficiency and transition to zero-emissions freight technologies in California's freight system (CARB, 2016). The draft California Sustainable Freight Action Plan was released in May 2016 and includes strategies to accelerate development and deployment of near-zero emissions technologies. This plan will be instrumental in leveraging the existing RNG+NGE technologies and resources to bring the next round of clean heavy-duty trucks to fruition.

California Climate Investments Program

The California Climate Investment program identifies priority investments for Cap and Trade funds to help achieve California's greenhouse gas (GHG) emission reduction goals, while considering health, economic, and environmental benefits (Air Resources Board, 2016). In May 2016, the State of California awarded \$23.6 million from this program to the

SCAQMD for a statewide zero-emission drayage truck development and demonstration project (CARB, 2016).

So far, funds have primarily been allocated for electric truck pilot projects with truck manufacturers including BYD, Kenworth, Peterbilt and Volvo. Political support, academic research, and community support are necessary to advocate for funds allocated to develop the renewable natural gas market and purchase the near zero-emissions natural gas engines from Siemens in addition to the electric truck demonstration projects.

CALSTART

In May 2015, the California Air Resources Board selected CALSTART to run the largest statewide clean truck and bus incentive program in the country. CALSTART allocated \$10 million in additional incentives from 2015-2016.

The program includes a Hybrid and Zero-Emission Truck and Bus Voucher Incentive Project (HVIP) that, unlike traditional rebate programs, is a simple web-based process without the typical lengthy application forms and delayed reimbursement (CALSTART, 2015). The ARB initiated HVIP in late 2009, and it has become the most significant program to encourage fleet operators to purchase hybrid and electric trucks instead of conventional ones. The program funding is comprised of \$5 million from the State's legislature in support of the Air Quality Improvement Program (AQIP) and is established by the California Alternative and Renewable Fuel, Vehicle Technology, Clean Air,

and Carbon Reduction Act of 2007 (Assembly Bill 118). It also includes \$5 million from the Greenhouse Gas Reduction Fund, which targets projects that reduce greenhouse gas emissions and provide low carbon transportation benefits to disadvantaged communities (CALSTART, 2015).

REGIONAL

SCAG Regional Transportation Plan

SCAG has made a firm commitment to support a more sustainable regional freight system. The 2016 RTP/SCS includes \$70.7 billion in goods movement strategies, including a system of truck-only lanes, modernized intermodal facilities, and deployment of commercially available low-emissions trucks and locomotives (SCAG, 2016).

Clean Air Action Plan and Clean Trucks Program

The Clean Air Action Plan and Clean Trucks Program continue to provide a platform to support low- and zero-emissions heavy-duty trucks; however, the funds to subsidize clean trucks have run out and the majority of truck drivers remain misclassified.

South Coast Air Quality Management Plan

The Southern California Air Quality Management District (AQMD) periodically prepares an Air Quality Management Plan (AQMP) to demonstrate how the region will meet federal and state health air quality standards to comply with the Clean Air Act (AQMD, 2014). AQMD is in the process of creating a 2016 AQMP, which will primarily address the ozone and PM2.5 standards. The Plan will be a collaborative effort

between AQMD, California Air Resources Board, Southern California Association of Governments (SCAG) and the U.S. Environmental Protection Agency (AQMD, 2014). The upcoming 2016 AQMP will develop strategies to meet the following National Ambient Air Quality Standards established by the U.S. EPA under the Clean Air Act: 8-hour Ozone at a maximum of 75 parts per billion (ppb) by 2032; annual PM2.5 at 12 µg/m³ by 2021-2025; 8-hour Ozone at a maximum of 80 ppb by 2024; 1-hour Ozone at 120 ppb by 2023; and 24-hour PM2.5 (35 µg/m³) by 2019 (AQMD, 2016). These standards will not be attainable without a cleaner fleet of drayage trucks at the Ports.

STRATEGIC INTERVENTIONS

CLEAN TRUCKS 2.0

Considering the environmental and health impacts of the thousands of heavy-duty trucks serving the ports each day, a near-zero to zero emissions truck program encompassing sustainability, social equity, and community power must be implemented immediately. It is essential to convene the relevant stakeholders in order to attain consensus and act swiftly to achieve the best and most feasible solution. Considering the state of the existing technology, the relatively affordable cost, and the opportunity to build the sustainable renewable gas market, the combination the Siemens natural gas engine fueled by RNG is the best option.

Grants and subsidies created by existing policies such as the Diesel Emissions Reduction

Program and CALSTART will have a much wider impact if allocated toward NGE+RNG trucks than expensive battery electric or fuel cell electric trucks. Ultimately, rectifying the misclassification of truck drivers will be the linchpin of an overall successful program that encompasses sustainability, social equity, and community impacts. The truck drivers and representative organizations including the Teamsters must have a seat at the negotiating table when developing the details of a Clean Trucks Program 2.0.

COMMUNITY AND STAKEHOLDER ENGAGEMENT

LAANE has an opportunity to organize support for a new Clean Trucks 2.0 program by mobilizing the Coalition for Clean & Safe Ports. With over 150 participating organizations from a diverse range of community and industry sectors, the CCSP should convene to establish their priorities and concerns for a Clean Trucks 2.0. Other key stakeholders include the Ports of Los Angeles and Long Beach, Mayor Eric Garcetti, the Los Angeles City Council, the Air Quality Management District, the Teamsters union, and the American Trucking Association. The Ports of Los Angeles and Long Beach would oversee the implementation process once a list of program details are established, including the time frame and phase-in process, available funding and subsidies for LMCs and IOOs, and enforcement mechanisms.

Clean Trucks 2.0 has the potential to be incredibly successful at both reducing NOx

and greenhouse gas emissions while helping to develop a fossil fuel-free renewable energy market in California. The program should solicit funds from all existing policies and grants, while drawing attention to the need for trucking companies (LMCs) nationwide to increase costs to cover their true expenses. The pervasive race to the bottom is unsustainable and inequitable. Fortunately, there is widespread recognition for these problems and increasing amounts of resources are being poured into developing a more sustainable freight system and fighting for justice for truck drivers through the legal system. There is a great deal of work to be done, but with increased cooperation from key stakeholders and additional funding, the current fleet of 14,500 heavy-duty diesel trucks can be upgraded to near-zero and zero-emissions vehicles. This will help the Los Angeles region reach impending air quality attainment standards while improving the health of port workers and local communities.

TRUCK-ONLY TOLL LANES

BACKGROUND: CONGESTION PRICING

Congestion continues to be a major problem for supply chain stakeholders and local communities located along major freeways and arterials serving the Ports. The surges in demand experienced as megaships offload

massive cargos travel all the way up the supply chain and are projected to reach levels beyond the capacity of existing ground infrastructure.

Experts who study congestion agree there are few ways to address the problem of excess demand on limited roadway space (Downs, 2005). These strategies can be roughly characterized as either supply side or demand side solutions. Supply side strategies involve increasing capacity, either by building larger freeways/arterials or through use of other modes, such as freight rail. Demand side strategies involve use of restrictions or fees, such as tolls, to redistribute traffic flows during peak hours. Congestion pricing, whereby fees are applied to travel at peak hours, are typically considered demand side strategies, but they may include the construction of some new facilities, which increases overall road capacity.

Congestion pricing strategies such as truck-only toll (TOT) lanes and PierPASS are elements of a broader strategy to address congestion and emissions reductions at the Ports, which also includes increased on-dock rail capacity and clean vehicle technologies. The following examines proposals for dedicated truck-only toll lanes along the I-710 and SR-60 freeways with respect to sustainability, social equity and community power outcomes.

TRUCK-ONLY TOLL LANES

Truck-Only Toll (TOT) lanes have emerged only recently as a congestion management strategy in concept. There are no examples currently of active TOT lanes in the United States, although various proposals and feasibility studies have

examined the possibility of TOT roadways in California (Killough, 2008), Atlanta (Fields, Hartgen, Moore & Poole, 2009), and Oregon (Cambridge Systematics, 2009). There are also no examples of TOT roadways abroad, although Britain, Italy, the Netherlands, and Canada have also considered their feasibility (Cambridge Systematics, 2009).

Although TOT lanes remain unprecedented in the US, tolling is gaining popularity to manage personal vehicle congestion. Both the I-110 east of downtown Los Angeles and the SR-91 Expressway from Orange to Riverside County serve as examples of High Occupancy Toll (HOT) lanes for passenger vehicles, which are considered highly successful based on revenue and demand (Sullivan, 2002; Fischer, Ahanotu, & Waliszewski, 2003).

Dedicated truck facilities do exist in the United States. These facilities involve restricted access to certain vehicle types, without the tolling component. They may result in capacity and safety benefits, but result in less effective congestion mitigation strategies than those that are paired with pricing schemes (De Palma et. al., 2008). Without the tolls, they are also less likely to offset peak-period travel delays and increase travel time reliability, making them less attractive and useful for the truckers who might use them.

TOT lanes are attractive for several reasons. Theoretically, they offer a way to manage demand for roadway space, increase safety by separating heavy from light vehicle traffic, and

generate revenue that can be funneled into infrastructure improvements. Several studies have attempted to model the potential costs and benefits of TOT lanes, demonstrating their potential to yield time savings (Meyer et. al, 2006; Killough, 2008); reduce greenhouse gas emissions (Killough, 2008); and generate revenue (Meyer et. al, 2006).

Usage of TOT lanes, and thus their efficacy at managing congestion, depends heavily upon the how truck drivers from various market segments value their travel time. Industry experts have demonstrated that those who value reliability or can convert time savings to extra loads may find the benefits of restricted access lanes outweigh the costs associated with the tolls; others who are paid by the mile may not (Cambridge Systematics Inc. & CH2M HILL., 2009). As discussed in previous sections, roughly 90 percent of the truck drivers serving the Ports are not classified as employees, but rather Independent Owner Operators, the vast majority of whom work more than 40-hour workweeks, do not receive employee benefits, and make less than minimum wages (see Current Status of Independent Owner Operators). These truck drivers are also responsible for the overhead costs associated with owning and operating their vehicles. The incidence of tolls levied on a per-mile basis on IOOs (instead of trucking companies or shipping companies) could prove cost prohibitive, which would undermine the ability of TOT lanes to effectively manage demand for these facilities.

Studies of the actual outcomes of TOT projects –environmental, economic, or otherwise – are nonexistent. Most of the economic analysis is derived from studies of HOV and high occupancy toll (HOT) lanes (de Palma, Kilani & Lindsey, 2008). By virtue of being theoretical experiments, these models reduce study parameters to overly-simplistic terms. In fact, as described by Meyer et. al. (2006), many considerations can go into implementing TOT lane programs, to say nothing of funding and/or financing mechanisms:

- Time of Operation: TOT lanes, like regular toll lanes, can be reserved for peak hours, operate 24 hours a day.
- Fee Structure: Fee schedules can be variable or fixed, and have minimum and maximum charges.
- Fee Rates: Different rates can be applied to heavy-duty versus light-duty vehicles.
- Access: The number of access points and associated infrastructure affects traffic flows.
- Phasing: Some proposals start with one or two lanes and expand to a broader network.
- Right of Way: Proposals have looked at ways to allocate roadway space, such as converting HOV to TOT lanes.

PIERPASS

The PierPASS program, launched in 2005 to address truck congestion at the Ports of Los Angeles and Long Beach, provides a different model of congestion pricing. Under the PierPASS program, a Traffic Mitigation Fee (TMF) was levied on containers moving into and out of the port terminals during peak periods (8:00 AM

to 5:00 PM Monday through Friday). The fees collected were used to extend gate operations at the terminals to off-peak hours (6:00 PM to 2:59 AM Monday through Friday, and all day Saturday and Sunday). Thus the TMF provided a financial incentive for shippers to move their cargo at off-peak times, with the hope of redistributing truck flows and easing peak-hour congestion.

PierPASS is the first program of its kind implemented in North America (Giuliano and O'Brien, 2008). As such, there is little research on TMFs levied on containers. The program was devised and implemented by the Marine Terminal Operators (MTOs), who created a non-profit, PierPASS, Inc. to administer the fees.

The fees collected by the program were used by the MTOs to pay for the additional costs of extended gate operations, including labor. Each MTO implemented the extended gate operations differently and not every terminal operated during each of the off-peak shifts. The fees were originally set at \$40 per TEU, but have been raised incrementally in response to rising costs of gate operations (Giuliano and O'Brien, 2008). Per the PierPASS, Inc. rate schedule, fees are currently set at \$69.17 per 20-foot container and \$138.34 for all other sized containers, adjusted annually in accordance with Pacific Maritime Association labor estimates.

Based on analysis of PierPASS Inc. data, only about 55-60 percent of truck cargo pays the TMF (Giuliano and O'Brien, 2008). Certain container types are exempt:

- Empty containers or empty chassis;

- Import of export containers entering and leaving during off-peak hours;
- Import or export containers that are subject to Alameda Corridor rail fees; and
- Transshipment cargo.

In 2006, the TruckTag program was also launched, which outfitted each container truck with a unique Radio Frequency Identification (RFID) tag to facilitate check-in/check-out at terminals and meet federal security clearances.

According to transportation freight experts (Giuliano & O'Brien, 2008), PierPASS was implemented by the MTOs in response to several factors: increased container volume through the Ports as a result of increased trade; public concern over the social and environmental costs of truck traffic, in particular, diesel particulate; capacity constraints at the Ports and the struggle to accommodate mega container ships; and finally, mounting political pressure from California lawmakers. Politics, in particular, may have played a large part in how the PierPASS program took shape. In 2004, California Assemblyman Lowenthal had proposed a plan to create a separate public authority, the Port Congestion Management District, with power to levy congestion fees, which would be pooled into public coffers to fund freight congestion mitigation projects. The MTOs were reluctant to be monitored by a third party, in this case a state entity, and instituted PierPASS as an alternative to the assembly proposal. By doing so, they retained control over both the oversight and the revenue generated by the program.

In terms of evening container flows, the PierPASS program has been successful. The program exceeded its first-year goal to shift 20 percent of all container moves to off-peak hours within the first month (Giuliano and O'Brien, 2008). The question remains, however, whether that redistribution resulted in lower emissions or improved lead times.

Two studies report the impacts of PierPASS on human health and environment (Bhagat et. al., 2014; Bhagat et. al, 2015). Neither study found any significant decrease in pollutants during peak hours due to reductions in congestion. During peak hours, daytime NOX and PM2 emissions dipped by roughly 5 percent, meanwhile nighttime emissions rose 19 percent. Thus, the redistribution of truck flows may have resulted in a net increase in emissions and annual health costs.

Whether or not stakeholders benefited from the program was very much dependent on their respective power within the overall supply chain (Giuliano & O'Brien, 2008). Generally, MTOs are very satisfied with the program; as a result, it has continued beyond the original three-year timeline. Drayage truckers, who are overwhelmingly IOOs and low-income immigrants (Monaco & Grobar, 2005), were not consulted during the development of the program and were more critical of the outcomes. Truckers surveyed by the California Trucking Association reported much higher rates of dissatisfaction with the program, namely because it failed to improve turnaround times. Truckers surveyed by PierPASS exhibited more favorable and mixed

attitudes about the program. Their responses indicated that the program still may have contributed to less desirable work schedules without an increase in pay.

PierPASS also creates several operational inefficiencies. The opening of the extended gate hours at 5:00 PM has created an "artificial peak" when truckers start to line up for the off-peak rate schedule (Giuliano & O'Brien, 2008). In addition, longshore workers go on break in the middle of their shift (10:00 to 11:00 PM). Work either comes to a complete stop, or must be accomplished as a higher rate. Truckers therefore aim to complete their run before 10:00 PM. MTOs still have to pay longshore workers for the full shift, which lasts until 3:00 AM.

CURRENT CONDITIONS AND TRENDS

REGIONAL BENEFITS, LOCAL COSTS

Although the Ports offer considerable economic benefit to the region, the state, and arguably the nation, they unload a disproportionate number of social costs on local communities. Truck flows contribute to significant congestion throughout the SCAG region, and tend to be more concentrated along highway links than arterials; with the exception of the arterial system in the vicinity of the Ports, LAX airport, and logistics hubs (Sorensen et. al, 2008). Many stakeholders share an interest in improving congestion in and around the Ports in order to increase travel time reliability and overall productivity, as well as mitigate air pollution and health impacts.

Congestion delays, and the consequences on travel time reliability, create major problems for shippers, truckers, and other supply chain actors. SCAG estimates that average weekday truck speeds along major freight corridors are as slow as 35 mph during A.M. peak period (SCAG, 2016). Logistics researchers (Regan & Golob, 2001) surveyed trucking industry managers and found that 80 percent of respondents consider traffic congestion on freeways to be a somewhat or critically serious issue. It was of particular consequence for private, for-hire firms involved in intermodal operations for reasons related to unreliable travel times, driver morale, and slow average speeds. Not all actors experience these impacts equally. Indeed, even among truckers, the costs of congestion delays (time, money, truck wear-and-tear) may vary depending on how truckers are paid (per-mile or by load). Moving further up the supply chain, there is also evidence that shippers are sensitive to container lead times (delays), perhaps even more so than overall transportation costs (Leachman, 2005).

Congestion along freight corridors also imposes major social, environmental and health costs to surrounding communities, the majority of which are low-income communities of color (Houston, Krudysz, & Winer, 2008). Diesel particulate released by passing trucks is linked to elevated risk of cancer and asthma, as well as reduced lung function in children (Hricko, 2008; Hricko et.al, 2014). As the region's largest polluter, the ports account for more than 20 percent of the diesel particulate pollution (Hricko, 2008). Ships, trucks, locomotives and handling equipment

– all diesel-burning equipment emits harmful pollutants; however, trucks are the leading source of both nitrogen oxides (NOx) and particulate matter (PM) emissions compared with other sources (Giuliano, O'Brien, Deblanc, & Holliday, 2013).

In 2015, the SCAQMD completed a study of urban air pollution and concluded that 70 percent of cancer risk in the LA Basin derives from particulate matter in diesel exhaust (SCAQMD, 2015). The SCAQMD also reported that, while cancer rates were in decline, communities in West Long Beach, Compton, and several others along the 710 corridor had the highest probabilities of cancer risk, more than 1,200 cases per 1 million people. The maps associated with this report, which stirred substantial outcry when first released in 2000, led to environmentalists designating the corridor a “diesel death zone” (Figure 4.13).

THE CLEAN FREIGHT CORRIDOR PLAN

The Southern California 2016 Regional Transportation Plan/Sustainable Communities Strategy (RTP/SCS) proposes a Clean Freight Corridor Plan (CFCP) to improve cargo throughput, safety, and incentivize the adoption of clean truck technologies. SCAG completes an RTP/SCS every four years, which includes a large freight analysis. SCAG is one of the few Metropolitan Planning Organizations to include a freight appendix, underscoring the significance of goods movement and logistics in the SCAG region.

Figure 4.13: MATES II CAMc Model Estimated Risk or Diesel Death Zone

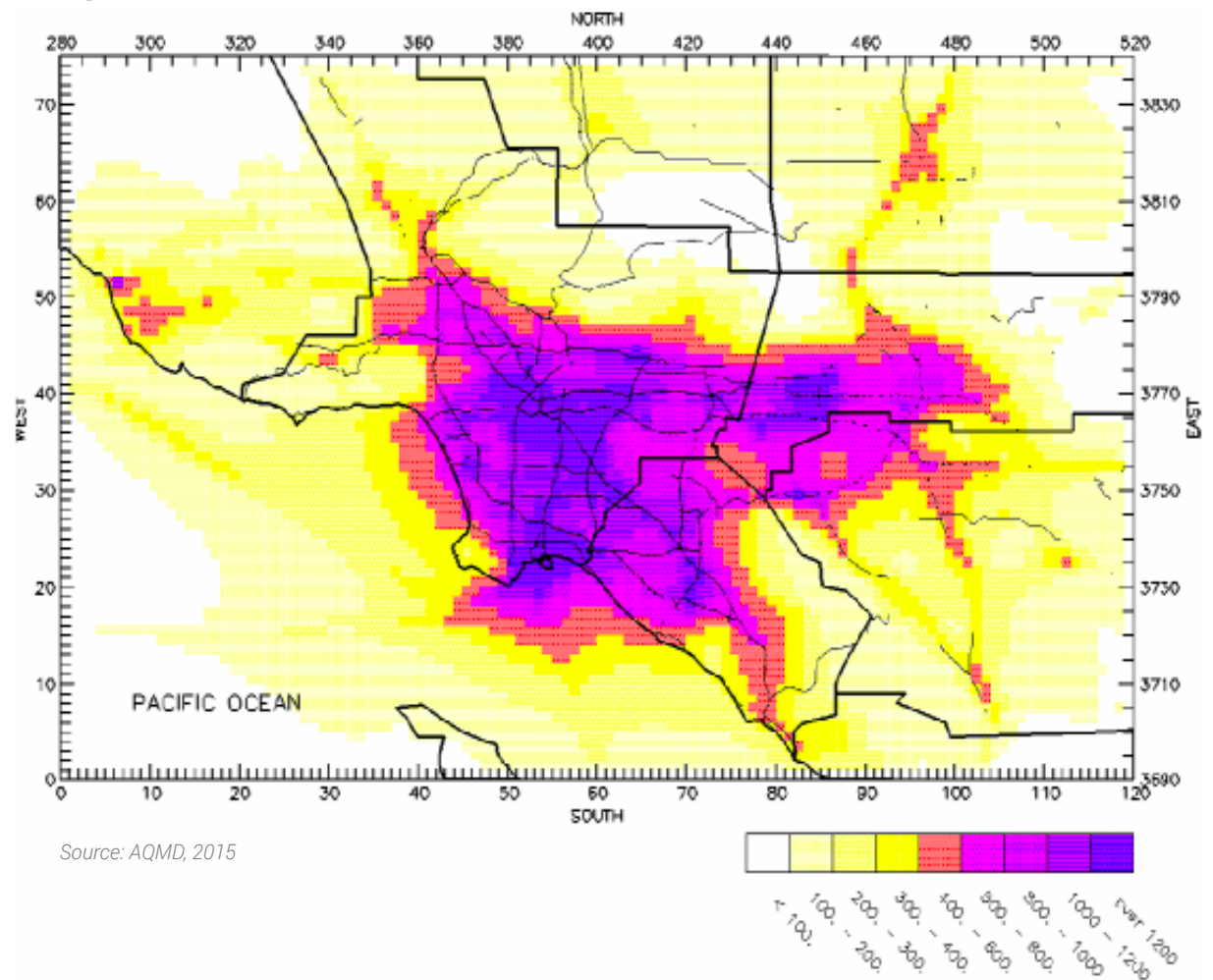

Source: AQMD, 2015

Truck-only toll ways were introduced as a possibility for improved truck mobility by SCAG as early as 1997 (Fischer, Ahanotu, & Waliszewski, 2003). In 2004, the RTP/SCS identified dedicated lanes on the Interstate I-710 freeway as a “viable and potentially self-financing solution for mitigating congestion and reducing mobile source emissions arising from surface transportation operations in Southern California” (SCAG, 2004, D-3-32).

Subsequent RTP/SCS/SCS documents have advanced this plan further, the I-710 corridor being just the first step in a progression towards a regional Clean Freight Corridor Plan. The Environmental Impact Report (EIR) for the I-710 freeway project, led by Metro, is currently under review. The community preferred Alternative 7 includes a four-lane zero-emission/near zero emission (ZE/NZE) freight corridor, although the plan does not propose adding lane capacity to the mainline of the I-I-710*. Feasibility studies for the SR-60 East-West Corridor are also currently underway. **Figure 4.14** shows a map of the truck distribution serving the Ports. Many of the origins and destinations are clustered along the I-710, prompting SCAG to identify this as a possible TOT lane corridor. Origins and destinations are also scattered towards eastern parts of LA County and the Inland Empire. An East-West TOT lane corridor would serve logistics hubs located in these areas. According to the 2004 RTP/SCS (Appendix D), the proposed system would include:

- 142 center-lane miles of dedicated truck lanes from the San Pedro Ports to Barstow;
- Carrying capacity of 3,200 vehicles, for a total of 10,905,600 truck-miles;
- Truck lane system covering the I-I-710, the SR-60, and the I-15 Highways;
- A graduated toll rate ranging from \$0.35 for lighter vehicles to a maximum of \$0.70 for heavier vehicles

Community in this circumstance includes several organizations representing residents of Wilmington, Long Beach, and other freeway

Figure 4.14: Distribution of Trucks Serving the Ports

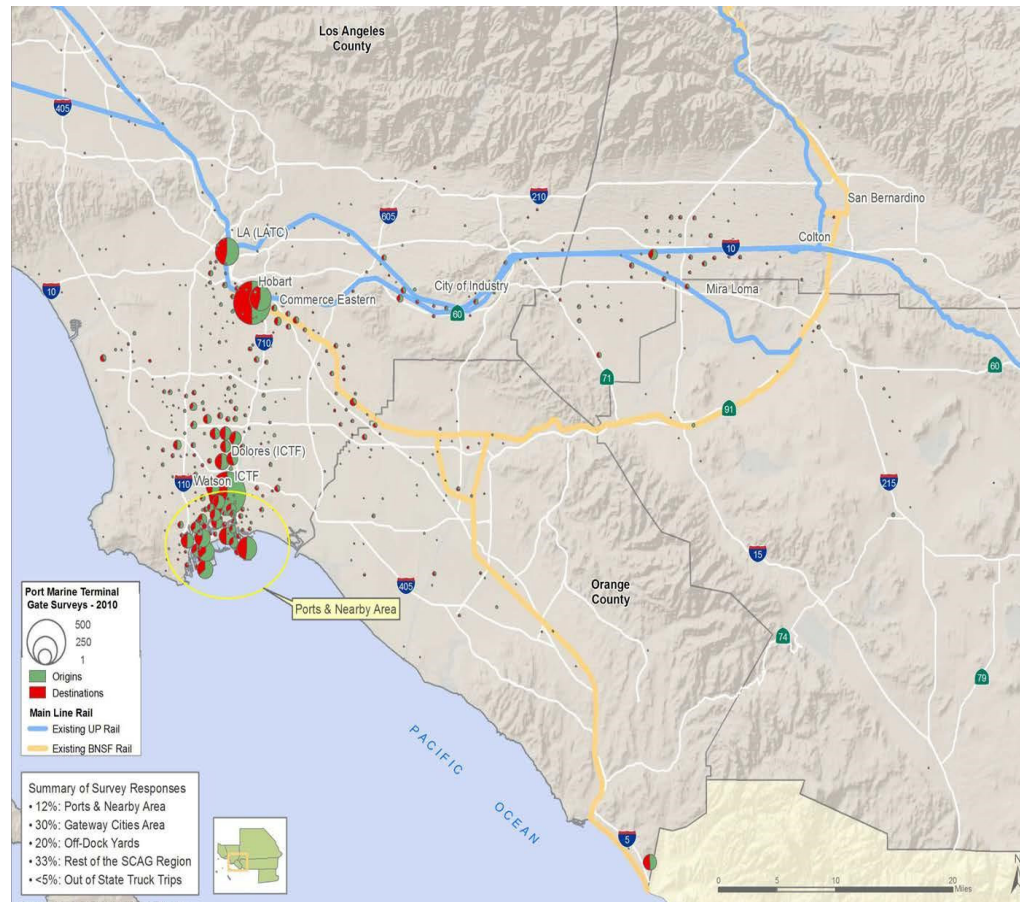

Source: SCAG, 2012

adjacent cities who participated in the development of this alternative: Communities for a Better Environment, Long Beach Alliance for Children with Asthma, Coalition for Clean Air, Great Long Beach Interfaith Community, Natural Resources Defence Council, Coalition for a Safe Environment, Legal Aid Foundation of Los Angeles, East Yard Communities for Environmental Justice, among others (Addison, 2013).

Although it is perhaps too early to determine where new right of way (ROW) will be built or precisely how fees will be levied (through what mechanism), it is likely that these agencies will pursue a per-mile based fee system, along the I-710 and SR-60, and that the action will involve the oversight of a Joint-Powers Authority (JPA). The JPA model used for the Alameda Corridor Project was considered successful by regional planners at SCAG (Nam, 2016).

The 2016 RTP/SCS estimates that the entire Clean Freight Corridor Plan will cost roughly \$25 billion in year of expenditure (YOE) dollars. The entire project would be rolled out in two phases. The first phase, completed between 2020-2030 would include widening the I-710 to five mixed flow and two dedicated toll lanes for clean technology trucks, and associated interchange improvements (\$5.1 billion in YOE). The second phase, to be completed in 2030-2040 or beyond, would involve a \$20.3 billion investment in the East-West Corridor spanning multiple counties along the SR-60. **Table 4.1** presents a summary of these costs and timeline.

Previous studies commissioned by SCAG evaluated whether the proposed toll ways could be self-financed through toll revenue, concluding that total revenue from the tolling system could exceed capital costs by a ratio of greater than 2:1 (SCAG RTP/SCS, 2004). These include studies completed by the Reason Foundation, a Libertarian think-tank dedicated to free market policy and principles (Poole, 2007; Samuel, Poole & Holguin-Veras, 2002).

Travel demand is a crucial element to tolling. In short, there has to be enough demand for the dedicated lanes to warrant tolling. Although the plan is presented by SCAG in the context of Port related truck trips, these trips actually only comprise about 15 percent of total freight traffic (SCAG, 2016). Demand considerations also include domestic freight trips, whose origins and destinations do not include the Ports or intermodal facilities.

SCAG representatives have indicated that lead agencies might consider pursuing a public-private partnership (P3) model (Nam, 2016). Even in this case, where the private sector helps to build or implement the tolls, the capital costs of this project will still likely require public subsidy. The P3 example from the SR-91 HOT lanes serves as a cautionary example. In 1990, the Orange County Transportation Authority (OCTA) used a P3 arrangement to expedite the delivery of HOT lanes along a 10-mile corridor from Orange to Riverside County. Several years into operation, it became clear that the private operator's incentives were not aligned with the agency's. In order to ensure demand for the toll lanes, the OCTA had agreed not to increase general capacity, which would compete with the express service (Siemiatycki, 2009). Eventually, the OCTA purchased the express lanes, eliminating the non-compete clause, and transferring their operation back into the public sector.

ENVISIONING SUSTAINABILITY, EQUITY, AND COMMUNITY POWER

The CFCP has the potential to offer positive impacts on safety, emissions, and productivity

touted in the 2016 RTP/SCS. But improvements in safety, emissions, and productivity do not guarantee the best outcomes for labor groups or neighboring communities. In an ideal scenario, truck-only toll ways, funded through public subsidy, would be devised by a consortium representing all those party to such an investment, including locally affected communities and labor groups. In addition, the revenue generated by such a venture would be reinvested in communities who contribute the public funds used to build the facilities and bear the social costs associated with goods movement.

Principles of a Just Transition

The Guidelines for a Just Transition developed by the International Labour Organization (ILO) offer a comprehensive set of guidelines to help policymakers envision and plan for a sustainable economy (International Labour Organization, 2015). These guidelines offer general principles by which governments, industry players, and businesses can promote sustainability, worker protections, social dialogue and green jobs, among other key targets.

The Clean Freight Corridor Plan proposal could have the positive impacts on safety, emissions

Table 4.1: Freight Corridor System Cost Estimate and Timeframe

Project	County	Project Cost (\$YOE, Thousands)	Timeframe
I-I-710 Corridor	Los Angeles	\$5,110,000	2020-2030
East-West Corridor	Various	\$20,312,357	2030-2040

Source: : RTP/SCS 2016

and productivity touted in the 2016 RTP/SCS. However, certain social equity and sustainability concerns would have to be addressed in order for the plan to meet the requirements laid out for a Just Transition.

Table 4.2 presents the relevant principles of a just transition and the major issues presented by truck-only toll lanes. Major challenges surface meeting emissions reductions targets, worker protections, public funding, democratization of the planning process, and use of toll revenue.

ENVIRONMENTAL CONCERNS (WILL TOLL LANES REDUCE EMISSIONS?)

Redistribution of truck flows and increases in overall VMT will offset reductions in emissions, and potentially result in a net increase in harmful pollutants if the CFCP is not implemented in conjunction with an effective clean trucks plan. This is demonstrated by the PierPASS program (Bhagat et al, 2014; Bhagat et al, 2015).

Similar findings have also been demonstrated for passenger vehicle HOT lanes. Sullivan (2002) reported that traffic increased steadily after the opening of the toll lanes, and was strongly correlated with time-of-day dependent travel savings (during the peak period). Aggregate emissions modeling demonstrated that emissions along the 91 toll corridor were about the same as if high occupancy vehicle (HOV) lanes or dual general-lanes had been constructed instead. In fact, emissions would be about 8 percent less had no additional capacity been built.

SCAG proposes to address this problem by limiting access to the toll lanes to cleaner vehicles. Without widespread adoption of cleaner trucks, however, this could impact demand and weaken the overall effectiveness of tolls as a congestion pricing strategy. The Clean Trucks 2.0 program should outline clear steps to finance the either the conversion of trucks to cleaner fuels or the introduction of new equipment.

The creation of dedicated truck facilities, and dedicated ROW, also facilitates the future implementation of other innovations, such as:

- Automated trucks capable of forming closely spaced, fuel-efficient platoons, or
- A full-electrified freight corridor, wherein power sources are run underground or overhead.

Table 4.2: Challenges to Just Transition

Issues	Challenges	Just Transition
Meeting emissions reductions targets	Increased vehicle miles traveled (VMT) due to number of trips offset the emissions reductions	Implementation of clean fuel technologies before or in concert with CFCP Conversion of CFCP for other fixed-route technologies
Worker Protections	Incidence of tolling	Resolution of IOO misclassification Trucking industry represented in the early planning stages
Public funding	Public subsidy of a project that will contribute large gains to private sector	Community benefits agreement (CBA) negotiated in exchange for public
Democratization of the planning process	Community groups marginalized during planning processes	Partnership with citizen groups, community representation in the JPA
Use of toll revenue	Private-public partnership (P3) arrangement could result in private operators setting toll prices for profit.	Tolls are used to maintain infrastructure or are reinvested into local communities via CBA

INCIDENCE OF TOLLING (WHO WILL BEAR THE COST OF THE TOLLS?)

Fees or tolls would most likely be levied upon truckers for access to the TOT lanes on a per-mile basis. Therefore, the incidence of the tolls would likely be borne by long and short-haul truckers who comprise the regional trucking market segments. The value of truck-only toll lanes will be determined by travel demand. However, if the system is cost prohibitive, IOOs and smaller private firms will not be able to utilize this service or recognize gains.

Various industry associations and researchers have investigated attitudes towards tolling and congestion pricing and found that opinions vary widely. Golob and Regan (2000) examined trucking industry and logistics managers' attitudes towards several congestion mitigation policies such as dedicated truck facilities, congestion pricing, and improvements in traffic management, among others. They determined that truck only facilities were favored by users involved in intermodal operations and just-in-time deliveries. Congestion pricing is also favored by some carriers who provide JIT services. However, neither strategy was favored by private fleet firms.

According to SCAG, approximately 85 percent of these trucks trips are internal truck trips, those with both an origin and a destination within the SCAG region, typically generated by local industries (SCAG RTP/SCS, 2016). The remaining 15 percent of these trips are either external or interregional, port related, or

intermodal (beginning or ending at an intermodal rail terminal). According to a study of trucking sector by Monaco and Grobar (2005), 90 percent of the truck drivers serving the Ports are IOOs, who earn on average below minimum wages.

The resolution of the misclassification of IOOs is directly related to how the TOT lanes will be used and their overall efficacy at delivering environmental and economic gains. Tolling cost should be incorporated into overall cost of goods, and be passed onto to shippers and eventually consumers. The ultimate price of these products should reflect the social costs of bringing these goods to market in a timely fashion.

DEMOCRATIZATION OF THE PLANNING PROCESS (WHO CONTROLS PLANNING EFFORTS?)

Transportation infrastructure projects have a long history of controversy due to centralized, top-down planning efforts that marginalized citizenry and brought displacement to many low-income communities of color (Sanchez, Stolz, & Ma, 2003; Bullard, 1997). Planning practitioners now recognize the need for public participation among traditionally underserved and underrepresented populations, but the question remains how to implement and assess public participation for greater social equity and effectiveness.

Arnstein (1969) provided a model that distinguishes degrees of participation, each step marked by increasing and more desirable levels

of engagement: 1) manipulation 2) therapy 3) informing 4) consultation 5) placation 6) partnership 7) delegated power and 8) citizen control. Planning for a just transition, with the goal of increasing community power, would necessitate seeking out an institutional model based on delegate power and citizen control.

Transportation experts Sorensen et al. (2008), who studied congestions problems in the SCAG region, also emphasize public participation and coalition building. They offer the following general recommendations with respect to building general consensus on transportation planning efforts:

1. Form a coalition of community representatives to fulfill the political leadership role
2. Include diverse stakeholders when forming the community coalition
3. Develop agreement on the need for aggressive action to halt growth in congestion
4. Define broadly, the problems associated with congestion to help foster agreement on need for action; and
5. Develop support for comprehensive programs rather than individual programs.

The Clean Freight Corridor Plan project does not fall under one agency's purview; therefore, it emerges as a likely candidate for a Joint-Powers arrangement. The JPA model was used to form two institutional bodies to implement the Alameda Corridor Project: the Alameda Corridor

Transportation Authority (ACTA) and the Alameda Corridor East (ACE). Both JPAs united several agencies and industry groups, but had key differences in structure that either facilitated or impeded consensus building and overall effectiveness (Callahan, Pisano, & Linder, 2010). Of the many lessons learned from this process, researchers conclude that 1) institutional design is critical for investments such as the TOT lanes, which span multiple jurisdictions; and 2) goals for the project should align with broader regional goals inclusive of social equity and sustainability (Callahan et. al, 2010).

COMMUNITY BENEFITS AGREEMENTS (WHO BENEFITS FROM THE TOLL REVENUE?)

Revenue generated by the tolls could be used to cover the operations and maintenance costs of the new tolling network. In order to meet the conditions of a just transition, however, communities affected by freight corridors, overwhelmingly low-income communities of color, should be involved in the planning of those facilities. In addition, some portion of that revenue should be reallocated into the communities who bear the social costs of increased truck flow along the major freeways.

In Southern California, examples such as the 110 Freeway Tolling CBA- Community Action Plan could serve as a promising model. When Metro proposed the HOT Lanes along the 110 Freeway, east of downtown, they held roughly 140 community meetings to engage local

residents who were willing to pay for the lanes in exchange for increased transit service and other concessions (Wachs, 2016). Therefore, this agreement allowed a benefit for one group of users (middle and upper income users of the HOT lanes) to benefit adjacent low-income communities.

STRATEGIC INTERVENTIONS

The creation of a truck-only toll network may have the potential to facilitate goods movement in the Southern California region and promote sustainability. The projected increases in truck volume will place enormous burdens on ground infrastructure in the SCAG region, and will have major impacts to local air quality, land use, health of nearby communities, and public spending. TOT lanes offer one way to redistribute the benefits associated with goods movement to the surrounding communities who bear the greatest social costs.

The implementation of TOT lanes in the SCAG region should align with broader social equity, sustainability and community power goals encapsulated in the terms for a just transition (ILO, 2015). Success in achieving these goals will predominantly determined by 1) the extent to which the facilities can be used to encourage cleaner vehicles 2) community and industry involvement in the early planning process and 3) the use of toll revenues for various community benefits.

The following interventions would result in a

more equitable distribution of power during the early planning process, encouraging a project design more attuned to the trucking industry's needs as well as the local community. **Table 4.3** presents these interventions and their relationship to social equity, sustainability and community power.

1. Implementation of clean vehicle initiatives to both incentivize and finance industry-wide adoption of zero-emission and near-zero emission technologies.
2. Organization of a JPA inclusive of community representatives and truck drivers to address concerns about public investment and tolling incidence.
3. Creation of a Community Benefits Agreement (CBA) in exchange for public subsidy.

These efforts alone, however, will not produce a wholly Just Transition. The adoption of federal level environmental regulations and the resolution of the misclassification of IOOs would also be critical components of a successful Clean Freight Corridor Plan.

INTERVENTION 1: ZERO-EMISSION OR NEAR-ZERO EMISSION INITIATIVES

Dedicated truck facilities have the potential to encourage use of cleaner vehicles. Toll ways may be restricted to certain types of clean vehicles, which coupled with time savings, may provide incentive for private trucking companies and IOOs to adopt zero-emissions or near-zero emission technologies. Certain financial constraints, however, may prohibit the adoption of these vehicles. Therefore, special

consideration should be devoted to various trucking market segments and the ability of private fleet firms or IOOs to afford new technologies. The costs associated with tolling and purchase of new vehicles may prohibit IOOs from using the toll lanes, which will affect travel demand and hence overall efficacy of the system.

Table 4.3: Interventions & Impacts on Equity, Sustainability, and Community Power

Intervention	Equity	Sustainability	Community Power
CFC planned in concert with ZE/NZE vehicle	Tolling and vehicle costs may prevent private firms and IOOs from participation	Emissions reductions along the corridor is dependent upon adoption of clean vehicle	ZE/NZE technology is consistent with Alternative 7
Community and industry representation in the JPA	JPA framework should reflect the range of community groups and industry (truck driver) interests	Broader representation will bring a better range of sustainability goals	Emphasis on partnership and citizen power rather than consultation
Community benefits agreement (CBA) negotiated in exchange for public investment	Toll revenue redistributed to assist adoption of community goals for sustainability	Sustainability outcomes dependent on how toll revenue is reinvested	Citizen control of toll revenue would be the ideal outcome

INTERVENTION 2: ORGANIZATION OF AN INCLUSIVE JPA

The JPA institutional framework used to implement the Clean Freight Corridor Plan should be inclusive of 1) various industry players as well as community groups as well as multi-jurisdictional governments and 2) social equity, sustainability and community power goals. The toll ways will be used differently by heavy duty and light duty vehicles serving local, regional and intermodal markets. Therefore, representatives from truck drivers in each of these market segments should be included in the planning process. Similarly, local governments, government councils, and community groups who will bear the external costs of the system should be engaged and empowered throughout the planning process.

The following agencies would be influential players in the formation of such a JPA and the planning and implementation of the Clean Freight Corridor Plan. The following does not constitute an exhaustive list of stakeholders who should be involved; however, rather it is intended to outline who the most powerful players might be in negotiating the agreements. Given the complexity of coordinating an array of jurisdictions and interests, the formation of a JPA could include a tiered

structure, where representatives from the Ports, planning agencies, and community groups are each given leadership positions on the governing board.

Southern California Association of Governments (SCAG). As the metropolitan planning organization for most of the Southern California, SCAG provides regional planning and travel modeling, but does not have power of implementation.

The Los Angeles County Transportation Authority (Metro). Metro allocated federal, state and local funding dollars for many transportation projects in the region. In partnership with Caltrans, they are currently leading the environmental assessment for the I-710.

Caltrans. The State Department of Transportation owns much of the right-of-way that would be used for dedicated truck facilities. They would likely serve as the lead agency for the East-West Corridor Project (Nam, 2016).

South Coast Air Quality Management District (SCAQMD). The pollution control agency overseeing most of the SCAG region. Many of the technological improvements designed to achieve reduced emissions are intended to comply with local and state air quality mandates.

The Ports. Both of the Ports have been involved in similar JPA arrangements, such as the Alameda Corridor Project. However, as landlord ports they have constrained influence over their tenant terminal operators.

Council of Governments. The Gateway Cities Council of Governments, San Gabriel Valley Council of Governments, and West Riverside Council would have jurisdictional claim to the CFCP.

Labor Unions. The ILWU and Teamsters unions should be integral to these negotiations.

Advocacy Organizations. Several advocacy organizations representing the citizens of Long Beach, Wilmington, and other freeway adjacent communities participated in the selection of the Community Preferred Alternative 7 for the I-710 corridor (Addison, 2013). These include:

1. East Yard Communities for Environmental Justice
2. Communities for a Better Environment
3. Legal Aid Foundation of LA
4. Long Beach Community Action Partnership
5. Coalition for Clean Air
6. Physicians for Social Responsibility

INTERVENTION 3: CREATION OF A COMMUNITY BENEFITS AGREEMENT

Finally, a Community Benefits Agreement should be negotiated in exchange for public subsidy. Special care is warranted should a P3 model be proposed, which could allow private interests to set toll prices and retain revenue. Local communities would ideally decide how to allocate toll revenue, whether to use it to subsidize ZE/NZE vehicles, build Green Zones, and/or reinvest in sustainability projects locally.

TRUCK AUTOMATION

Automation technology will have a transformative impact on the trucking industry over the next several years. While 100 percent automation penetration in the trucking industry is at least a decade away, considerable progress is being made by several companies. As a result, the National Highway Traffic Administration (NHTA) has recently released basic industry-wide standards and guidelines for the development and implementation of the technology. The technology itself is expected to be implemented in four major phases, with 100 percent automation penetration emerging between the late 2020s and early 2030s. While fully automated driverless trucks are expected to be in urban centers last (i.e. POLA and POLB) given the complexity and safety issues inherent to cities, dedicated truck lanes can potentially accelerate this process. Ultimately, the overall benefits and negative externalities, in short, the social equity issues in trucking automation are mixed. For instance, decreases in job access and employment losses are expected, but safety, job quality, and efficiencies improving environmental sustainability are expected to increase. These issues and their impacts will play out as the technology is developed and implemented over the next decade.

TYPES OF AUTOMATION IN TRUCKS

As noted, there are different types of vehicle automation depending on the level of technology

used. The National Highway Traffic Safety Administration categorizes five different levels of vehicle automation. Each defines the specific capabilities and functions of the technology, seen in **Table 4.4**. As noted in Table, the present state of vehicle automation is currently in phase two, corresponding to level three, limited self-driving automation.

TRENDS IN AUTOMATION

Four major phases have been identified in the development and implementation of automation technology over the next decade. **Figure 4.15** illustrates the time span of these four phases, with 100 percent automation penetration occurring in 2026. However, these forecasts cover automation technology in its general terms. There is an expected delay in its adoption in the trucking industry. For instance, Google's self driving car has, as of March 2016, test driven its vehicle over a span of 1,498,214 million miles. While there is only one instance of an automated truck with equivalent capacities in the testing phase, the research and illustrations are informative to the field of truck automation. This truck, however, is limited only to non-urban roads, whereas no such limitation exists with the Google driverless car. The four phases of implementation are as follows.

- **Phase 1:** Passive Autonomous Driving is expected to be on the road in several locations across the country by the middle of 2016. The first state to see this technology on public roads is in Nevada. California

is expected to follow suit within the next several months.

- **Phase 2:** Limited Driver Substitution is expected to be fully implemented 2019.
- **Phase 3:** Complete Autonomous Capability is expected to penetrate the trucking industry by late 2022.
- **Phase 4:** 100 percent Automation industry-wide is estimated to be in effect by 2026 (Aldena, 2015).

Again, while phase four is expected to have 100 percent penetration by 2026, it is not clear when this will occur within the trucking industry. What is certain is that urban centers (i.e. the ports) will likely be the last to benefit from the technology.

However, the implementation of dedicated truck lanes may facilitate and hasten this process

CURRENT STATE OF TECHNOLOGY

As of today, the technology is currently in the developing stages of Level 3, limited self-driving automation. There are two general technological pathways currently in development. The first is the production of new trucks with automation technology built in to the truck itself. This method is being spearheaded by Daimler Trucks North America (DTNA), an automotive industry manufacturer of commercial vehicles headquartered in Portland, Oregon. The

second path is the upgrading of existing trucks with automation technology; the company developing that second path, Otto, is still conducting research.

In 2015, Nevada became the first state in the country to license trucks using level three automation technologies by DTNA. This technology is still in the pilot stage and it could be “at least 10 years before self-driving 18-wheelers are ready for the road, although the delay could have more to do with policy issues rather than technology lag” (Newcomb, 2015). For instance, DTNA notes that the replacement of side physical mirrors with cameras and monitors, “which could reduce drag and increase fuel efficiency by 1.5 percent, has been a regulatory uphill battle (Newcomb, 2015). Nevertheless, DTNA’s automated trucks are leading the way in the production of new trucks with the automation technology built in. **Figure 4.16** illustrates the truck itself, the primary technological systems of the truck, and the cabin where the driver can be seen using a tablet device to control the truck’s operations and navigation systems

Otto is a San Francisco based company recently established by 40 former employees from Google, Apple, Tesla, Cruise Automation, and others (Ziegler, 2016). Its goal is to “turn commercial trucks into self-driving freight haulers (Ziegler, 2016). The company intends to do this by making “hardware kits for existing truck models that would either be installed by service centers or possibly at the factory if the company is able

Table 4.4: Types of Automation Technology

Type	Stage	Description
No Automation	0	The driver is in complete and sole control of the primary vehicle controls – brakes, steering, throttle, and motive power – at all times
Function Specific Automation	1	Automation at this level involves one or more specific control functions. Examples include electronic stability control or pre-charged brakes, where the vehicle automatically assists with braking to enable the driver to regain control of the vehicle or stop faster than would otherwise be possible.
Combined Function Automation	2	This level involves automation of at least two primary control functions designed to work in unison to relieve the driver of control of those functions. An example of combined functions enabling a Level 2 system is adaptive cruise control in combination with lane centering
Limited Self-Driving Automation	3	Vehicles at this level of automation enable the driver to cede full control of all safety-critical functions under certain traffic or environmental conditions and in those conditions to rely heavily on the vehicle to monitor for changes in those conditions which require transition back to driver control. The driver is expected to be available for occasional control but with sufficiently comfortable transition time.
Full Self-Driving Automation	4	The vehicle is designed to perform all safety-critical driving functions and monitor roadway conditions for an entire trip. Such a design anticipates that the driver will provide destination or navigation input but is not expected to be available for control at any time during the trip. This includes both occupied and unoccupied vehicles.

Source: Aldena, 2013

Figure 4.15: Automation Technology Timeline

Timeline for Adoption

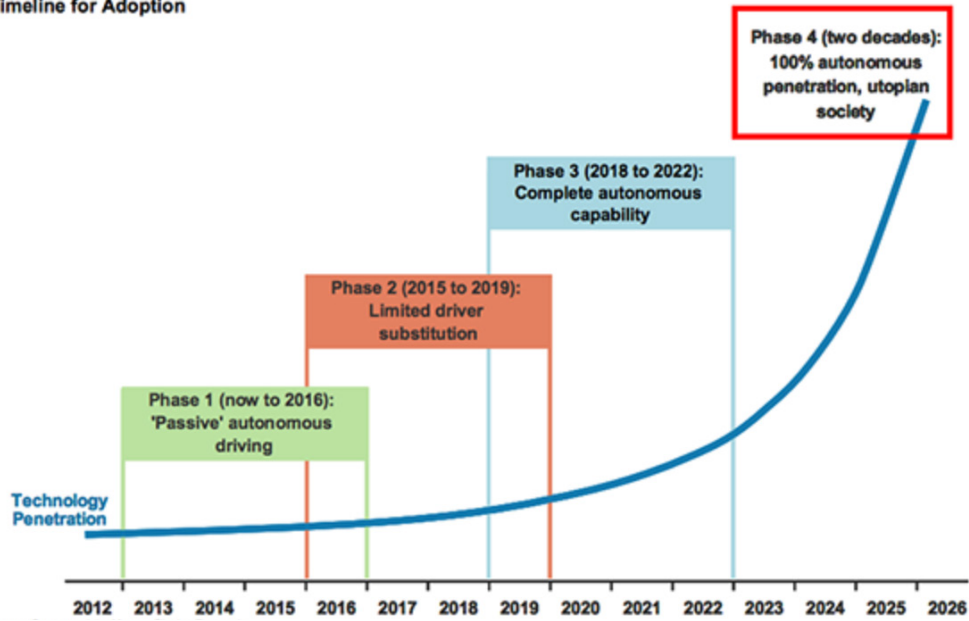

Source: Santens, 2015

to forge manufacturer partnerships (Ziegler, 2016). However, this technology is focused, at least initially, on highway driving rather than surface streets, loading, or unloading, which would require a driver (Ziegler, 2016). As of now, the company is starting a pilot program with the Volvo VNL 780, shown below in **Figure 4.17**. Nevertheless, the company plans to expand to all Class 8 trucks, which are the largest, heaviest trucks on the roads (Ziegler, 2016).

LABOR AND ECONOMY

DRIVER SHORTAGE

One of the major issues within the context of truck automation is the driver shortage in

the industry. This issue will likely continue to shape the political economy, labor, and technological issues surrounding truck automation. This is because fully automated driverless trucks are viewed as a possible solution to the current industry expressed driver shortage. **Figure 4.18** illustrates the shortage of drivers over the next several years according to several industry analysts. As observed, the shortage of drivers by 2022 is significant, reaching an estimated 239,000 by 2022 (Badkar, 2014). A more reserved figure by the American Trucking Association (ATA) estimates this shortage to reach 176,000 by 2024. (Castello, 2015) This shortage is expected to affect the capacity of carriers on several fronts, particularly, in their ability to meet the expected growth in demand for carrier services over the next several decades.

The driver shortage described above may in fact be artificial and the result of the trucking industry's current operational practices, particularly, as it relates to recruiting/retaining practices. That is, the driver shortage "exists only in the minds of those unwilling to pay the price of resolving it" (Park, 2012). Essentially, the current conditions of the driver are unattractive to those the industry is attempting to appeal to. Today, "Drivers have choices as well, and

Figure 4.16: DTNA's Autonomous Truck Technology



Source: Santens, 2015

one of them is staying away (Park, 2012). While truck automation is often viewed as the solution to this shortage by carriers, the fact is that drivers will still be necessary for at least another decade as the technology is still in the early stages of development. Unless the trucking industry reexamines its current practices with drivers, it is likely driver shortages will remain. In addition, while the introduction of technologies such as Hyperloop may contribute to a lower need for trucking from certain points in goods movement, "It is highly unlikely that the driver shortage could be reduced in any significant manner through modal shift (i.e., shifting a large amount of freight from the highway to the rails or another mode)". (Park, 2012) This sets the stage for the introduction of automation as a possible solution to the problem.

JOB ACCESS

The implementation of automation in the trucking industry must be separated into two categories, long-haul (between cities) and short-haul (within cities). Job access for these two sectors will vary with automation. Once the technology reaches fully automated driverless trucks, it is expected that the demand for drivers will lessen. Drivers, however, will still be needed for at the next decade as the technology is still only in the early stages of development.

This tension is likely to continue as the technology develops. Employers have an inherent interest, as is the case with automation in other sectors of the economy, to do away with the worker through automation. This is expected

Figure 4.17: Otto's Automated Truck Technology



Source: Ziegler, 2016

to be a driving force in the industry's development and implementation of the technology and it will likely seek out policies that favor a driverless future. For instance, the American Transportation Research Institute (ATRI) estimates that approximately "34 percent of trucking's operational costs per mile is driver pay" (Castello, 2015). In combination with the drop in fuel prices, driver pay is "quickly becoming the largest operational cost" for motor carriers (Castello, 2015). This cost is

expected to continue to grow, especially as demand for drivers continues to rise (Castello, 2015). In addition, driver's themselves are often associated with other costs. For instance, it is estimated that "60 percent of wasted truck fuel is caused by driver over acceleration" (Morris, 2012).

While this may be true for a great deal of trucking carriers, those operating with mostly IOOs may not have the same incentive in this sense. For instance, in the IOO model, drivers are responsible for all truck overhead, including fuel. Their pay is a derivative of a small surplus in payments for each delivery, which averages to \$28,700 a year. (Rainey, 2014) The issue here is then whether truck automation makes economical sense for employers to adopt, which includes purchasing and maintaining their own fleet of automated trucks versus contracting IOOs. This distinction is not yet clear given the early stages of the technology and the unknown costs of its production on an industry wide level. However, the automation technology being developed by Otto, which only retrofits existing trucks with automation capacities, may in fact make the transition more economical in the long-run then contracting with IOOs. Again, this is still unpredictable given the current state of the technology.

As of now, the highest demand for drivers is in long-haul. This sector has the highest turnover rates. **Figure 4.19** illustrates the turnover rates for long and short-haul trucking. As observed, the turnover rates for for-hire long-haul trucking are significantly disproportionate. According to Bob Castello, Chief economist at the American

Figure 4.18: Driver Shortages 2010 - 2022

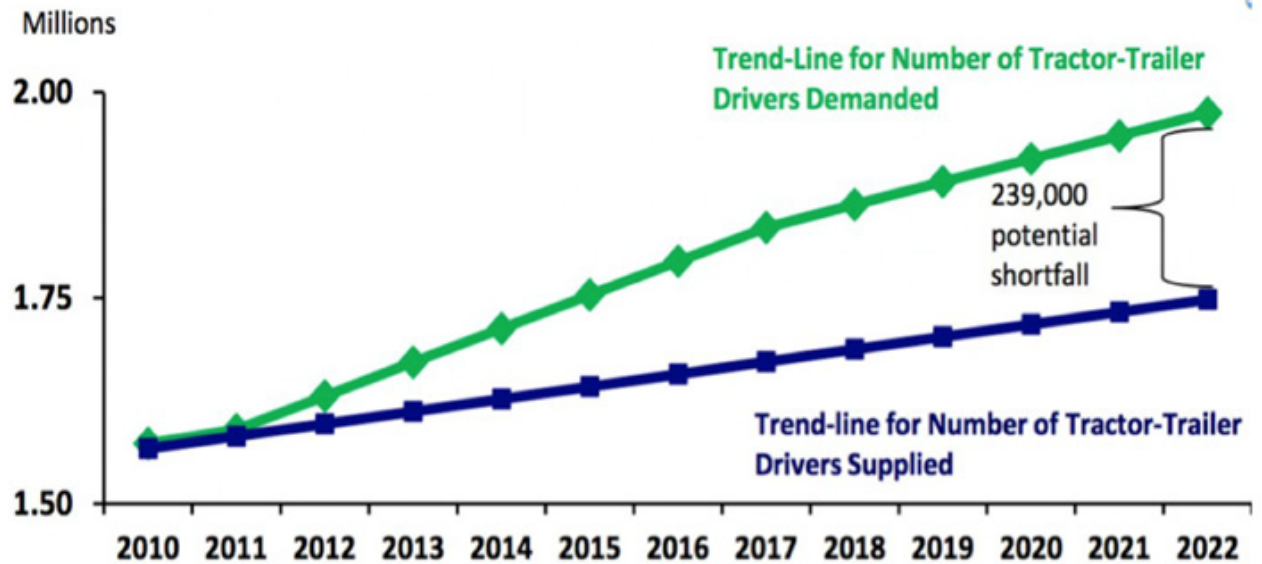

Source: Badkar, 2014

Trucking Association (ATA), this is primarily the result of the lifestyle associated with long-haul, which usually entails being away from home for days and spending long hours on the road. As such, automation technologies will likely, at first, more relevant to long-haul than short-haul (i.e. the ports). However, dedicated truck-only lanes may in fact facilitate the broad use of automated trucks at the local level sooner than later.

As a result of the current shortage of drivers, carriers have begun to increase wages and other benefits in order to attract new drivers. For instance, many carriers are offering sign-up bonuses for new drivers. According to the ATA, this has increased by 33 percent for less than truckload LTL carriers (local) in 2015. (Castello, 2015) **Figure 4.20** illustrates this change relative to other carrier services such as long-haul (TL) and private companies. These increases are expected to continue growing as the ATA estimates that approximately the shortage continues, which means job access will remain strong, even as the technology develops as drivers will still be needed with 100 percent automated driverless trucks.

JOB QUALITY

Job quality as a result of automation in the trucking industry will be mixed. Automation is expected to yield positive increases to working conditions, as drivers will no longer be expected to drive the

trucks for most of the trip. Automation will allow drivers to cede most of the truck's operations to the trucks themselves, which will demand less of drivers. This means more rest and time to do other activities. In the short-run, the benefits from partial automation systems will "enhance the performance of human drivers and increase efficiency" (Morris, 2015). This can have a positive impact on wages as a driver's income is often determined by his or her performance. As the technology advances, however, and less is required of the driver, the expected impact on wages is anticipated to be negative as the demand for the driver is diminished by the automated technology. The impact on wages is still unknown. Drivers on fully automated trucks, however, will still need to be qualified, especially in cases where the technology ceases to function. In addition, automated technology is expected to significantly increase safety for everyone on the road, including drivers. (Eisenstein, 2016)

Figure 4.21 illustrates the drop in trucks involved in crashes per 100 vehicle miles from 2000 to 2040. As can be observed, the drop in accidents is significant, with a drop from 70 percent in 2020 to only 10 percent by 2040. Other positive impacts to job quality are reductions of traffic jams and higher driver retention as a result of more efficient trips.

FINANCE

The cost of automation, particularly, completely automated trucks, is still unknown. As a result, the total cost of operation (TCO) of autonomous technology is "still not clear" (Kilcarr, 2015). It is estimated that most of the cost of autonomous

Figure 4.19: For-Hire Driver Turnover rates or Long-haul / Short-haul Trucking

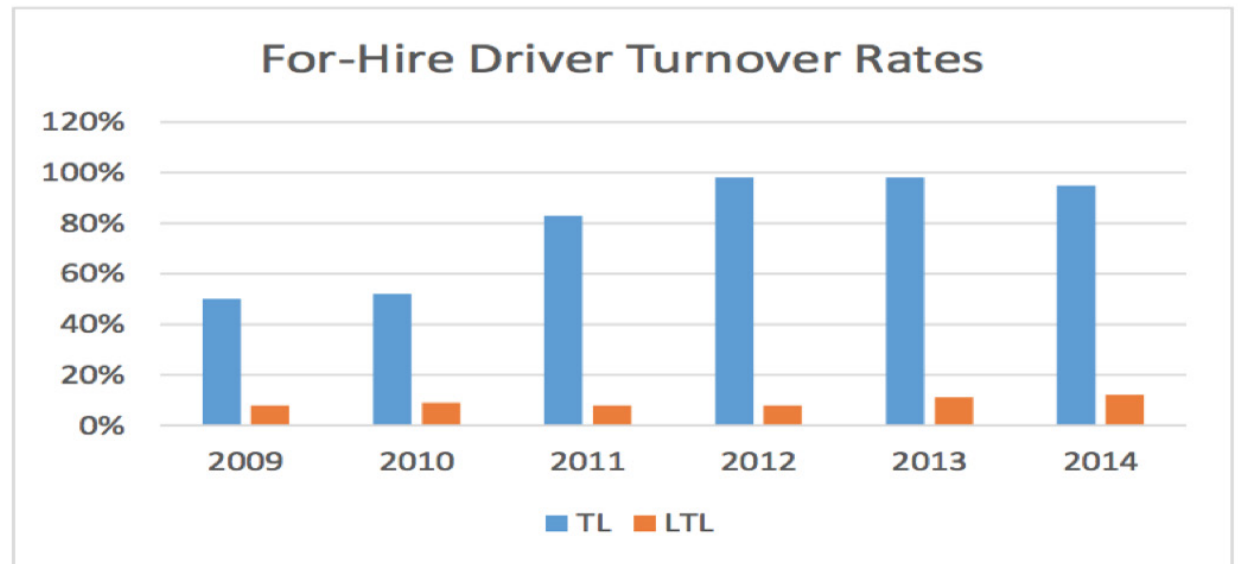

Source: Castello 2015

trucks will be in software rather than the hardware "about 80 percent of the total costs" according to some estimates (Kilcar, 2015). This can range somewhere between "\$4,000 and \$7,000 per stage, not including the \$5,000 premium for a fully-automatic or automated mechanical transmission (AMT) needed to make a truck "self-driving." These costs, essentially, will depend on the truck and the level of automation present. For instance, as of now, Stage 1, "driver assistance" technologies are "already in the marketplace – such as the aforementioned collision mitigation and lane keeping systems," which have already priced into the costs of the truck. Stage 2 "partial automation" technologies, which include "automatic emergency braking (AEB)," are currently in the road tested phase and may be available in 2017. However, the more complex technologies, such as Stage 3 "coordinated automation" that have the capacity for "truck platooning," is not expected to be on the market until 2020 and its costs are expected to be much higher, yet still unknown. This is true for the Stage 4, limited self-driving capability, as well, which is expected to be on the road in 2025."

While the cost of automated trucks is still unknown, the cost of automation may change significantly with the developments being made by Otto. This is primarily true as the company is developing both the hardware and software that will upgrade existing trucks, meaning the cost is expected to

be significantly lower than the production a new truck with the technology built in. For instance, Otto expects the cost of their technology to be only a “small fraction” of a truck’s \$100,000 to \$300,000 sticker. (Ziegler, 2016) However, as of now there is still “no price or timeline for Otto’s commercial products” but it is nevertheless expected to lower the cost of upgrading to an automated truck.

It is important to note that no public funding is expected at any stage of the development of automated trucks and thus public intervention on the issue will be limited. In fact, public intervention on the development and implementation of automated trucks will mostly be relegated to the regulations governing the technology, which are highly contested in California as of today (Ziegler, 2016) Current regulations, for instance, still require steering wheels and pedals, which impacts the total cost of production of automated trucks (Ibid). As such, any intervention impacting the development and implementation of automation technology on trucks must be done at the policy and regulatory level.

CONCLUSION

Automation will impact the trucking industry in very significant way. The trucking industry will need to hire a “total 890,000 new drivers, or an average of 89,000 per year” in order to maintain expected demands on carrier services” (Castello, 2015). While trucking automation may increase the attractiveness of trucking i.e. job quality, it

Figure 4.20: Percentage of Carriers Offering Sign-On Bonuses

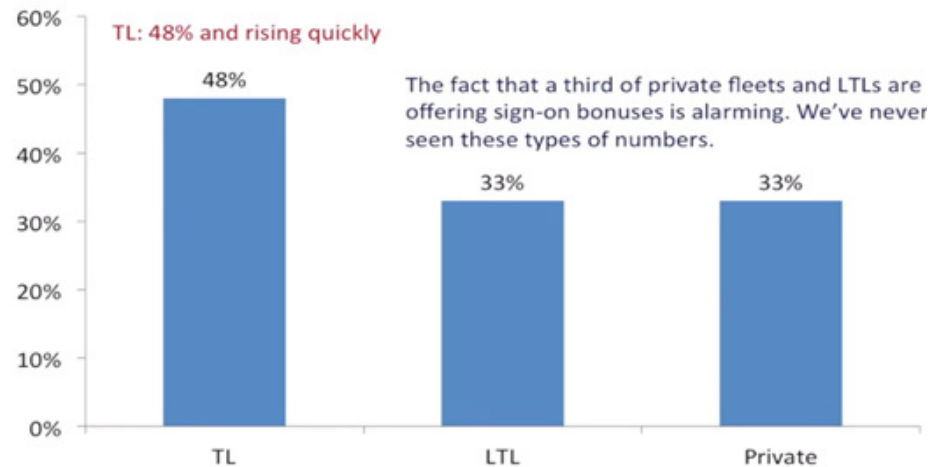

Source: American Trucking Association, 2015

Figure 4.21: Automated Trucks and Their Disruption Potential

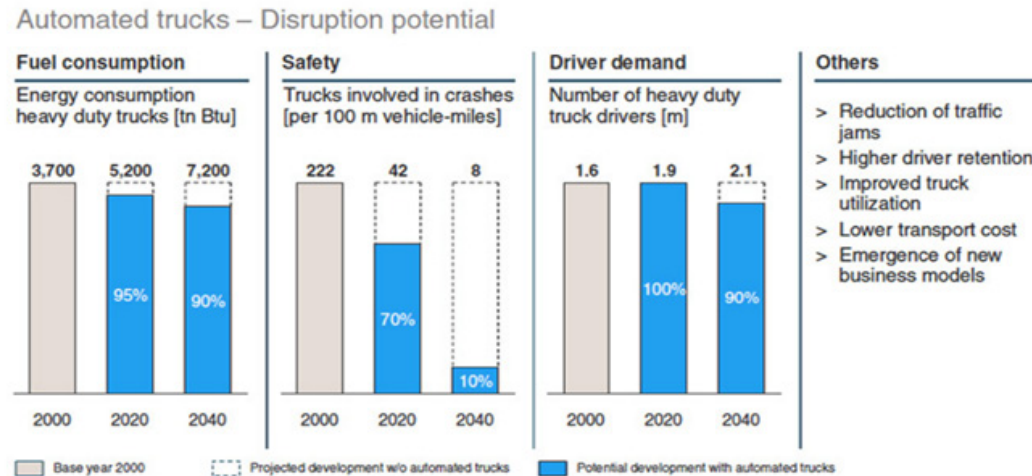

Source: Eisenstein, 2016

will not resolve this problem, as drivers will still be necessary for the foreseeable future. In fact, only a 5 percent reduction in the demand for drivers is expected to occur from 2020 to 2040 (Eisenstein, 2016). As such, the industry will need to change its current employment practices to a more equitable system in order to begin dealing with the issue of the driver shortage.

Future Infrastructure Technology: Hyperloop Overview

Although a list of infrastructure projects have been identified by SCAG to 2040, there is one privately-funded project that has plans to enter goods movement market, the Hyperloop. In 2013, Elon Musk published a white paper promoting Hyperloop technology and its theoretical advantages for transporting people and goods (Musk, 2013). Since then, multiple private ventures have created teams to explore this technology for both freight and passenger mobility. Hyperloop One, one of the companies developing this tube technology, conducted its first public test run of a Hyperloop propulsion system and expects to have a full test run by the end of 2016 (Hall, 2016). CEO Rob Lloyd of Hyperloop One predicts the company will have a Hyperloop freight system running by 2019 and a passenger system by 2021. This is a highly aggressive timeline, which does not account for the environmental clearance process. Nevertheless, the claims and finances behind

Hyperloop make it worth considering the impact of this fifth mode of transportation into the current freight system.

HYPERLOOP TECHNOLOGY & BENEFITS

Elon Musk's 2013 white paper placed held Hyperloop technology in the highest regard for semi-long distance travel options. Ideally, a Hyperloop system would be safer, faster, and less expensive than any other mode of transportation (Musk, 2013). Explained in simple form, Hyperloop technology is the transportation of people and cargo within a capsule that is suspended by electromagnetic forces and travels within a near-vacuum tube system. Using magnetic forces to repel the capsule while attracting it to move forward and accelerate, an air compressor to reduce friction, and an electric propulsion system, capsules could be transported at up to 700 miles per hour. The Hyperloop's theoretical design would take up less right-of-way than rail and could be propped onto an aerial structure. These factors suggest lower construction costs and Musk compared the land impacts to that of utility poles along a highway system.

Currently, an economic and technological feasibility study is being conducted by Hyperloop One and its partners for a freight transport system in Southern California. The system would have direct connections at the Ports, intermodal rail yards, and distribution centers around the region

(**Figure 4.22**) (Arcturan Sustainable Cargo, n.d.). As results of this local study have yet to surface, a shared-value study was recently conducted by German researchers for a cargo Hyperloop. The following are a summary of findings for a two-tube, aerial cargo system in Northern Germany (Werner, Eissing, & Langton, 2016). While the analysis is for a European system, some general conclusions can be translated to the Southern California region:

- Travel Time: Given Elon Musk's prediction of Hyperloop travel speeds of 700 mph, this would increase travel speed by over 1,000 percent. If all container cargo is transported by Hyperloop instead of drayage trucks, it would reduce the amount of vehicle traffic on the highway system.
- Operating & Maintenance Cost: The electric powered Hyperloop system would be most competitive in an expanded system which reduces cost with economies of scale. In addition, the reduction of heavy trucks on roads will improve the overall lifespan of pavement and reduce the need for resurfacing and replacing roads, bridges, and other facilities. Overall, the reduction in on-road traffic would provide the greatest societal benefit.
- Safety: A tube cargo system would effectively eliminate the need for an operator, and its aerial structure would minimize conflicts with other modes of transportation. The enclosed system would also be immune from most weather conditions.
- Noise Pollution: There is a potential for

noise pollution along a proposed Hyperloop route, but it can be addressed by the alignment of the tubes through areas with higher population densities. Since a capsule would be sitting on an air cushion, it is the movement of air along the interior walls which causes noise.

- Air Pollution & Climate: With an electric system, the Hyperloop would reduce overall emissions that normally would be emitted from diesel truck engines. The system would also reduce CO2 emissions, which could be then be sold in a Cap & Trade system.

OTHER CONSIDERATIONS FOR SOUTHERN CALIFORNIA

In addition to the issues incorporated by Werner et. al. (2016), the following are other impacts that should be considered for Southern California:

- Aesthetics and Obstruction of View: An aerial Hyperloop system can potentially obstruct the view of residents and communities adjacent to the structure. The tube diameter needed to transport a standard container would have to be over 12 feet high. This in addition to support pylons spaced every 100 feet would raise concerns. However, given the plans of the freight corridor along I-710 and SR-60, such an obstruction may already be planned. Thus it could be mitigated by creating a design that would fit each impact community's character.
- Workforce & Industry Impacts: An automated Hyperloop cargo system would dramatically

Figure 4.22: Hyperloop One Proposed Route for Southern California



Source: <https://hyperloop-one.com/global-challenge>

decrease the need for drayage trucks and alter truck flow patterns. In theory, the predicted Hyperloop system would begin at the port terminal, where it will be able to interface directly with the ship or terminal longshoremen. Then, the system would be connected to intermodal facilities and automatically loaded onto rail for long distance hauling, or it would be sent to cross-docking centers and loads would be redistributed to local retailers. This would effectively leave many trucking companies and independent truck owner/operators out of work. However, since this infrastructure would only support port containers, commercial trucking should be unaffected. In addition to labor, the placement of container terminals has the possibility of shifting major distribution centers to these locations. Hyperloop could potentially reduce the cost of transportation and exponentially decrease travel times which favors the locations closest to the terminals. From **Figure 4.22**, intermodal rail facilities are projected to be the main terminal locations, which will replace the need for on-dock rail at ports, to on-dock tubes. These areas could also be the new staging yards for container pick-ups, as opposed to the ports. If the Hyperloop is coupled with automated terminal operations, drayage

truckers could bypass the congestion at port terminals and instead, pick-up containers at these new Hyperloop terminals, effectively reducing travel time and time in traffic.

- Implementation & Usage Cost: The potential cost to retailers and shipping companies to use the technology has fueled some reservations about Hyperloop. Jolene Hayes, a senior freight consultant for Cambridge Systematics, stated that one of the biggest obstacles for Hyperloop could potentially be the price to transport each container (Hayes, 2016). Hyperloop One has offered to fully fund the construction of a system if given the space at a port terminal and intermodal yard, but the issue here is if the technology is not competitive and eventually abandoned, these facilities will be need to make use or dispose of the infrastructure.

As of now, the Hyperloop is still in its inception phase, but with an aggressive timeline and financial backing, there may be benefits for Southern California to incorporate this technology into the region's transportation system (One, 2016). Unlike the internet, the Hyperloop is a physical system that requires a massive amount of infrastructure if it were to serve multiple facilities and regions. The layout of the system is similar to an ultrahigh speed railroad network without established right of way and with more aggressive environmental standards. In the long run, it may come down to which communities, if any, are willing to have it in their backyards. Without the political capital and acceptance of the general public for a real Hyperloop system, the technology may be available in the future, but not permitted for use



5

SUPPLY CHAIN MANAGEMENT CASE STUDIES

MEGHMIK BABAKHANIAN, SALLY HENG, LINDSEY JAGOE,
EDBER MACEDO, & STEPHANIE TSAI

CHAPTER 5: SUPPLY CHAIN MANAGEMENT CASE STUDIES

CASE STUDIES: WALMART, COSTCO, AMAZON

The current structure of the Southern California logistics system fails to account for the negative externalities imposed on the local community and environment. To better understand and contextualize the aspects of the logistics system described throughout this report, the project team looked at three importers, known as beneficial cargo owners (BCOs): Walmart, Costco, and Amazon. These three companies were selected for their status as major players in the system as well as in their respective markets. They are also consumer-facing businesses widely known by general audiences.

As explained in Chapter II, large retailers and BCOs hold concentrated power within the current “pull” model of the logistics system. BCOs legally take possession of goods at the point of entry, but in many instances, they manage the costs and logistics associated with producing, transporting, and selling goods along the entire supply chain. This structure signifies the great deal of power that BCOs hold in negotiating labor and transportation costs.

The following case studies assess the historical context of each retailer and the political climate and business decisions that led to their current power in the market. Each case study was developed through the lens of social equity, community power, and sustainability. The information from the case studies, along with the analysis of neoliberal policies and supply chain trends, was used to develop a series of recommendations. These changes would create a more socially equitable, community-driven, and sustainable logistics system.

METHODOLOGY

To analyze the three businesses and supply chain models, the research team reviewed literature, including primary and secondary sources, and conducted spatial analysis and interviews. The types of sources ranged from official company publications, books, periodicals, and academic research papers to documentaries, historical papers, government resources, and documented first-hand experiences. The Costco research included a site visit and guided tour of the company’s Southern California Depot 960 in Mira Loma.

The following three case studies are structured with an introduction to each retailer’s market share and important historical events followed by a summary of their supply chain structures and an analysis of social equity, community power, and sustainability for each business model.

TABLE 5.1: CASE STUDY WAREHOUSES & DCs IN THE SCAG REGION



Source: Walmart, Costco, Amazon

CASE STUDY: WALMART

In order to understand Walmart's rise to power, it is vital to understand the history of world trade and globalization since the 1970s. In the 1970s, neoliberal economics became the dominant global trade policy. Among many others, economist Ioannis Kessides ran a number of regressions relating trade liberalization to growth and found that "strong liberalization episodes are associated with higher increases in the rate of gross domestic product (GDP) growth than weaker episodes" (Baldwin & Winters, 2007). In the 1980s, the comparative advantages of trade liberalization were realized; this global trade framework was strengthened in the 1990s with the assistance of international agreements set by the General Agreement on Tariffs and Trade (GATT) and later the World Trade Organization ("WTO | About the organization," n.d.).

As a result of global trade shifting towards trade liberalization, developing nations were offered the opportunity to increase their exports and GDP. At the same time, technological advances improved drastically in the 1990s and allowed for more efficient and lower-cost shipping. During these global changes, Walmart became one of the first corporations to take advantage of America's embrace of trade with China in the late 1990s. As corporate America started to hail East Asian countries as the new economic frontier, President Bill Clinton signed a permanent trade agreement with China (Smith & Young, 2004). The picture painted by officials was that American companies and people would benefit by exporting American-made products to the over 1.2 billion people of China at the time (Smith & Young, 2004). However, the combination of the former and the devaluation of the Chinese currency resulted in most of the US manufacturing jobs being outsourced to cheaper-producing countries and led to the eventual downfall of production in the US (Smith & Young, 2004).

Walmart has steadily replaced its American manufactured products with low-cost Asian imports since the 1980s and currently imports approximately 70 percent of its merchandise from China (Chan, 2011). Undoubtedly, Walmart's increasingly large imports from East-Asia have heavily affected the goods movement system, specifically in the Ports of LA and LB. For this reason, it is important to understand Walmart's rise to power and the role that Walmart has played in the goods movement system.

The benefits of having efficient supply chain management have been exemplified by Walmart in its rise as the world's largest retailer and publicly traded employer. With approximately 2.2 million employees around the globe and recorded revenues of approximately \$482 billion in 2016 ("Walmart 2016 Annual Report," 2016), Walmart has played a leading role in developing an efficient supply

BY THE NUMBERS

2.2 Million
Full & Part-Time Employees

\$482 Billion
Revenue during FY 2015

42
Distribution Centers in the US

\$25.6 Million
Earnings of Walmart's CEO
during FY 2015

Source: Walmart Annual Report, 2016 & Che, 2015

CASE STUDY: WALMART continued

chain system that prides itself in providing “everyday low prices”. The company has been able to reach its success through a combination of technological advancements, reducing the need for warehouses, operating in strategic locations, forcing its suppliers to act as price takers, and taking advantage of globalization. This case study describes the strategic factors that contribute to Walmart’s supply chain efficiency.

First, Walmart has been a leading pioneer in introducing information technology infrastructure to forecast demand, analyze demographic preferences, track inventory levels and needs, and set profit maximizing prices. In 1983, they were the first to implement the Universal Product Code companywide which was used to store inventory information (Dranow, 2014) and communicate it to the suppliers and manufacturers within their supply chain. This synchronization provides real-time information to its suppliers, which helps them plan, forecast, and replenish products and also allows retailers to pull merchandise to stores rather than push goods onto store shelves. Recently, Walmart encouraged its suppliers to use radio frequency identification (RFID), which aimed to improve back room inventory inefficiencies; however, unreliability and high costs prevented the project from full implementation of the project (Rosenblum, 2014).

Second, Walmart has eliminated the middleman and the associated costs that come with it. Prior to opening the first Walmart store in Rogers, Arkansas in 1962, founder Sam Walton owned several Ben Franklin variety franchise stores where he purchased bulk merchandise and transported it directly to his stores without the help and expenses of a third party (“Sam Walton,” 2008). Walton continued the practice of cutting out the middleman when he established Walmart, and by the 1980s Walmart further cut costs by working directly with manufacturers. They were able to do this using a private satellite communications system where “Walmart transmits point-of-sale (POS) information to suppliers to keep them informed about sales activities and trends.” Suppliers/manufacturers then prepare orders that can be easily cross-docked at Walmart’s distribution center (Kulwiec, 2004). This highly successful collaboration technique has improved material flow and lower surplus inventory.

Furthermore, cross-docking has been critical in replenishing inventory efficiently and eliminating the need for warehousing. The direct transfer of products from inbound to outbound trucks or rail cars has reduced the need for storage. Instead, Walmart has created distribution centers (DCs) where products are cross-docked and delivered to nearby stores, reducing the need for products to idle in warehouses for a long period of time

(Soni, 2015). This has reduced inefficiencies in transportation time and overall transportation costs. Replenishing quickly, using cross-docking, and not owning warehouses have been key factors in Walmart’s ability to keep costs low and remain in a position of power among retailers.

This leads to the next factor that contributes to delivering the goods to store shelves on time—close proximity of distribution centers to major US roads. Currently, Walmart operates 42 regional general merchandise DCs that total over 50 million square feet of space (MWPVL, n.d.). These massive DCs act as a valve regulating the flow of merchandise to Walmart stores and are strategically located near US Interstate Highways and other major roads. As shown in Figure 5.1, Walmart’s DCs in the Southern California region are within 0.5 miles of a major road. The close proximity of the DC to Interstate Highways provides easier access and lower transportation costs from the Ports of LA and LB. Close proximity also provides easy access to population centers and stores, which gives Walmart a competitive advantage in the market. Walmart’s commitment to providing “everyday low prices” entails forcing suppliers to act as price takers, which has helped lower Walmart’s prices, by reducing the profit margin of its suppliers. Some of Walmart’s biggest suppliers, such as Procter and Gamble, continue selling to

CASE STUDY: WALMART *continued*

Walmart despite profit decreases because Walmart is one of their largest customers. For instance, 17% of Procter and Gamble's goods are supplied to Walmart (Bonacich & Wilson, 2008). If Procter and Gamble were to dispute the prices set by Walmart, another supplier willing to provide a similar product for a lower price would replace them. This race to the bottom has put suppliers at a disadvantage, forcing them to act as price takers rather than price setters. In fact, Walmart's bargaining power and large market share controls and pressures suppliers to engage in environmental degradation and violation of labor laws both domestically and internationally.

Bangladesh is expected to surpass China within the next few years as the largest garment exporter (Fox, 2013). However, recent waves of deadly accidents and inhumane working conditions in garment factories have resulted in negative international attention. The average minimum wage for a garment worker in Bangladesh is estimated to be \$37 per month, one of the lowest in the world (Sethi, 2013). Even though factory owners have complained about the situation, the pressure from their foreign buyers has prevented any major improvements from taking place. Meanwhile, Walmart's Chief Executive Officer received \$25.6 million last year (Che, 2015).

In November of 2012, a tragic fire killed 112 garment workers and injured many more at the Tazreen Fashions factory, a large supplier for Walmart clothing (Yardley, 2012). Reports revealed "the plant lacked adequate fire prevention and exit systems. Furthermore, the plant managers blocked some of the staircases, preventing workers from exiting" (Sethi, 2013). In the aftermath of the fire, Walmart denied knowledge about Tazreen Fashion making their merchandise and announced that they would terminate any relationship with them. However, the factory had a history of unsafe working conditions and this was not the first fire incident revolving around garment producers in Bangladesh. What is important to note here is that Walmart, as well as other retailers, have never acknowledged "that their demand for the lowest possible price and extremely tight delivery schedules may have been a significant contributing factor toward lower wages and hazardous working conditions" (Sethi, 2013).

It is evident that Walmart's development of a highly structured and advanced supply chain management strategy has enhanced their competitive advantage and provided them with power to exploit workers and the environment for their own benefit. Simultaneously, they have undermined social equity by ignoring the working conditions and wages of the workers who supply their products in order to keep their costs low.

It is evident that Walmart's development of a highly structured and advanced supply chain management strategy has enhanced their competitive advantage and provided them with power to exploit workers and the environment for their own benefit.

Simultaneously, they have undermined social equity by ignoring the working conditions and wages of the workers who supply their products in order to keep their costs low.

CASE STUDY: COSTCO

Defined as a “membership warehouse club,” Costco Wholesale Corporation’s business model differs from other beneficial cargo owners (BCOs) in a distinct way. Unlike Walmart and other big-box retailers who utilize warehouses to sort, store, and distribute goods to retail stores, Costco’s warehouses simultaneously serve as their stores. This business model combined with point of sale technology (POS) allows for extreme efficiency within the company’s supply chain.

After a series of mergers, Costco opened its first location in Seattle, Washington in 1983. Costco grew from nothing to \$3 billion in sales in less than six years (Costco Wholesale Corporate Profile, 2016). Now with over 702 warehouses worldwide, including 120 sites in California, Costco has a membership-base of 81.3 million individuals and 44.6 million households (Costco Wholesale Corporate Profile, 2016). Each warehouse stocks approximately 4,000 different products, almost all of which are marked up 14 percent or less over cost (Stone, 2013). With reported annual revenue of \$116.2 billion in FY 2015, Costco is the US’s largest warehouse club operator (Soni, 2016). Furthermore, Costco’s rate of inventory turnover is considerably higher than its competitors. In 2015, Costco had a turnover rate of 11.6 compared to Target’s 5.8 and Walmart’s 8.1 (Soni, 2016).

In regard to supply chain operations, Costco’s main rule of efficiency is to eliminate the amount of “fingerprints” a good receives (Wulfraat, 2014). According to Costco’s Director of Merchandise Services and Environmental Services Peter Hesketh, “the more a product is touched along the supply chain, the more issues that could arise including damaged and lost goods” (Hesketh, 2016). But Costco’s real secret to efficiency is their utilization of cross-dock infrastructure. Hesketh states, “We believe we do cross-docking better than anyone else in the industry” (2016). Costco purchases products directly from manufacturers, then routes the product through a network of cross-docking infrastructure within their distribution centers before it is transported by truck to stores (Wulfraat, 2014). Once a truck arrives at a cross-docking facility, the product will be in a store in less than 24 hours; once at the store, the product is taken off trucks and placed onto shelves by forklifts (Wulfraat, 2014). Ideally, the goods are not physically touched until a consumer places the item into his or her shopping cart (Wulfraat, 2014).

Another reason Costco’s cross-docking facilities are so efficient is their ability to influence their suppliers. Because Costco purchases large volumes of goods from their suppliers they have economic power to influence how their suppliers operate. For example, within the last few years Costco has mandated that their suppliers package and load their product a particular way to streamline the unloading process (Hesketh, 2016). Previously, suppliers were loading product-containing palettes onto trucks in an inefficient manner that made it difficult for employees to unload more than one

COSTCO GENERAL MANAGER EXPLAINS CROSS-DOCKING AT THE BCO’s MIRA LOMA DEPOT IN THE INLAND EMPIRE



Source: Goetz Wolff, class site visit

COMMUNITY SCHOLARS SITE VISIT AT COSTCO’S MIRA LOMA DEPOT



Source: Goetz Wolff, class site visit

CASE STUDY: COSTCO *continued*

pallet at a time (Hesketh, 2016). Once Costco mandated that the goods be packaged and oriented a particular way onto the trucks, pallets were able to be unloaded 10 at a time (Hesketh, 2016). While these standards enable Costco to save time and money during the cross-dock process, their suppliers have to spend greater resources meeting the BCO's request.

Within the US, there are 13 Costco distribution centers. The distribution center for Southern California, which services 90 stores in Southern California, Hawaii, Mexico, Taiwan, Japan, Korea, and Australia is located in Mira Loma and is over 1,000,000 square feet (Hesketh, 2016). Refer to Figure 5.1 for Costco's Southern California store and distribution center locations. During FY 2015, the Mira Loma distribution center imported 11,000 containers and processed 6.4 million pallets (Hall, 2016). Furthermore, the distribution center employs 900 part-time and full-time workers and does not use temporary workers (Hall, 2016).

The Mira Loma distribution center was built on 120 acres of land purchased in 1997 (Hall, 2016). Costco received several incentives from the municipality of Mira Loma, including exemptions from the fire code (Newman, 2016). The location of the Costco distribution center was not based upon the interests of the residents of Mira Loma but rather the inexpensive cost of land, negotiations with the local municipality, and proximity to regional highway systems (Newman, 2016). The location of the distribution center did not take into account community concerns.

The development of the Mira Loma distribution center was in conjunction with the construction of several other distribution centers within the Inland Empire (De Lara, 2013). As previously stated in Chapter III, the clustering of distribution centers and warehouses within communities of the Inland Empire has been linked to an increase in cancer rates resulting from particulate matter emitted from diesel trucks (Newman, 2012). Costco is not taking action to mitigate the pollution impacts resulting from the proximity of the Mira Loma distribution center to residential land uses.

Costco strategically builds cross-dock facilities where there is adjacent room to expand, if need be (Hesketh, 2016). With the emergence in popularity of e-commerce, Costco has purchased land adjacent to the current distribution center with plans to increase e-commerce facilities (Hall, 2016). This addition will generate more diesel-emitting traffic within the Inland Empire, with little to no attention paid to the health effects of the pollution on adjacent communities.

Costco has been praised by consumers and industry analysts for its conscientious labor standards. In terms of employment, Costco employs approximately 200,000 full and part-time

BY THE NUMBERS

200,000

Full & Part-Time Employees

\$116.2 Billion

Revenue during FY 2015

13

Distribution Depots in the US

1 Million

Square Footage of Southern California's Mira Loma Dept

6.4 Million

Pallets Process in Mira Loma Depot during FY 2015

Source: Costco Wholesale Corporate Profile, 2016

CASE STUDY: COSTCO *continued*

employees worldwide (Costco Wholesale Corporate Profile, 2016). Costco employees have an average hourly wage of \$20.89, compared to the California minimum wage of \$10 an hour and Walmart's average wage of \$12.67 an hour (Stone, 2013). Additionally, 88 percent of Costco employees have company-sponsored health insurance (Stone, 2013). Since Costco went public in 1985, Wall Street has repeatedly placed pressure on the company to reduce wages and health benefits (Stone, 2013). Instead, former CEO James Sinegal boosted wages and benefits every few years (Stone, 2013). Costco's Chief Financial Advisor Richard Galanti asks, "Could Costco make more money if the average wage was two or three dollars lower? The answer is yes. But we're not going to do it" (Stone, 2013).

In terms of social equity, higher industry wages are a positive aspect of Costco's business model. However, the company is not necessarily supportive of unions. Although Costco's official stance on unions is neutral, recently there was conflict between Costco and the Teamsters Union, which represents approximately 15,000 Costco workers through the US (Levine-Weinberg, 2016). Among its "relatively small unionized workforce," Costco recently faced criticism from the union over its retirement benefits package (Levine-Weinberg, 2016). The Teamsters called on Costco to make a higher contribution to the current pension plan, which would provide employees more security during retirement (Levine-Weinberg, 2016). The

negotiations are yet to be finalized. Workers at Costco facilities are able to vote by location to determine unionization (Hall, 2016). The 13 distribution centers in the US are not unionized, nor are Costco's fleets (Hall, 2016).

According to Costco's 2015 Sustainability Report, Costco is "inherently more carbon-efficient than other retailers." The report states that the "bulk" emphasis of Costco's business model results in fewer trips by customers to serve their needs, and the cross-docking distribution system minimizes the trips needed to keep warehouses stocked (Costco Wholesale Sustainability Report, 2015). The company does admit that increased regulation to limit carbon dioxide and other greenhouse gas emissions will affect their profitability, but this potential reduction in profitability does not prevent the company from supporting such regulations (Costco Wholesale Sustainability Report, 2015).

Although Costco tracks direct and indirect emissions from natural gas, diesel, and propane from Costco's truck fleets, refrigerated trailers, yard haulers, corporate jets, and air conditioning equipment, they do not analyze how these emissions affect the communities in which they operate. Instead, the 2015 Sustainability Report is focused on positive business practices that Costco does well, including the implementation of sustainable packaging design, the installation of more Solar PV infrastructure, the use of LED lighting in warehouses, a reduction in the use

of plastic materials, and waste diversion and organic waste recycling programs.

Furthermore, Costco's sustainability-related policies are focused on reducing costs rather than benefiting the environment and making the air cleaner for communities residing and working adjacent to their stores and distribution centers. The solar power infrastructure significantly reduces energy costs and the current recycling program was developed to increase revenue. Additionally, in instances where Costco owns its fleet, diesel gasoline is utilized (Hall, 2016). For both long haul and drayage trips, Costco hires third-party trucking companies and does not regulate their emissions (Hesketh, 2016). The clustered prevalence of diesel emitting vehicles in the Inland Empire has been tied to increased cancer rates within adjacent communities (Newman, 2012).

Costco's concern for social equity, including wages, is better compared to other BCOs. However, the lack of concern for communities affected by pollution suggests Costco places little to no emphasis on community power and vision. In terms of sustainability, Costco publishes regular literature about the corporation's sustainable policy, yet the actual practices read as cost-saving measures rather than an explicit desire to ensure a safe environment for their workers, consumers, and communities living and working near Costco locations.

CASE STUDY: AMAZON

Background

Amazon.com opened for business as an online bookseller in July 1995 and quickly grew to become a retail giant and a household name. By 1996, Amazon had recorded \$15.7 million in sales and 180,000 customers. The following year, the company went public on the NASDAQ Global Select Market with the symbol AMZN and reported revenues of \$147.8 million and 1.5 million customers (Bezos, 1997). In 2015, Amazon “became the fastest company ever to reach \$100 billion in annual sales” (Amazon, 2015).

As of the first quarter of 2016, Amazon’s revenue was \$29.1 billion, with a net income of \$513 million (Alba, 2016). While Amazon has been a giant in online retail for two decades, it has historically prioritized growth over profit, investing heavily in its development and infrastructure rather than maximizing profit in the short term. The company has only recently begun to post profits (Alba, 2016). The company’s investments in itself can be seen as a reflection of its core functions. In many ways, it is more a logistics and infrastructure company than anything else; this has been the key to its success as a retailer and service provider. This case study briefly points out some key highlights of Amazon’s logistics models; the study is not meant to be comprehensive, as the company’s complexities and the extreme variety in goods and services offered are beyond the scope of this report.

Headquartered in Seattle, Washington, Amazon has over 230,000 full-time employees, (Profile, 2016) not including an untold number of temporary, seasonal, and contract workers. With offerings and services covering an almost inconceivable range, it is known as “the everything store.” The company is not a manufacturer; rather, it is perhaps best known and described as a provider of invisible services, which is key to its competitive advantage in the industries that it operates in. In online retail, Amazon provides speedy, convenient, and low priced delivery through its robust logistics operations. While this case study focuses on the main online retail structure that Amazon is most publically known for, it is worth noting that Amazon Web Services similarly provides invisible behind the scenes services in information technology infrastructure for millions of customers worldwide across many different industries, including many of the most well-known internet companies.

The company’s enigmatic founder, Jeff Bezos, worked in investment banking in New York City prior to launching Amazon. Many of the company’s core principles and its culture are direct reflections of his personal philosophy and mission to make Amazon “Earth’s most customer-centric company.” In alignment with this mission, Amazon has pioneered and mastered home delivery and supply chain management to the delight of millions of

customers. Indeed, the company’s intention for Amazon Prime and Prime Now delivery has been for the prepaid ultra-fast delivery service to be so good that a customer would be stupid not to use it. By setting and perpetually pushing the standards for speed, convenience, and price, Amazon sets standards for logistics providers as well as consumer expectations.

Fulfillment & Distribution Operations

Amazon’s logistics operations encompass its own direct retail as well as Fulfillment By Amazon (FBA), which provides marketing, sales, and fulfillment services to third party retail businesses. Third parties sell via the Amazon platform but stock their own inventory, so it never sees an Amazon warehouse shelf. Typically, in this model, Amazon receives an order, and the third party either ships it directly to the consumer or ships it to an Amazon FBA facility to be shipped to the consumer. In 2014, third parties made up about 40% of items sold on Amazon (Wohlsen, 2014). Often, consumers are not aware of whether their purchased goods are stocked by Amazon or a third party. This model allows Amazon to broaden its reach and business by selling goods that it does not source.

Amazon is estimated to have approximately 120 warehouse facilities globally, some 100 of them

CASE STUDY: AMAZON continued

in the United States (Times, n.d.). According to MWPVL International, a Canadian consulting firm specializing in supply chain logistics and distribution, Amazon currently operates some 162 facilities in its distribution network in the United States, including Zappos.com, Endless.com, and Diapers.com (MWPVL, 2016).

As is evident in **Table 5.1**, Amazon's logistics centers come in four different categories. Fulfillment centers are the largest, at about a million square feet and typically 1,000 to 2,500 full-time staff. Fulfillment centers are where customer orders are filled. They are warehouses full of conveyor belts and people picking and packing products. Sortation centers are much smaller, at 200,000 to 300,000 square feet, and require less staff, typically 100 to 300 people (MWPVL, 2016). Sortation centers are a key component for the last mile of the delivery process, and are thus often located closer to metropolitan areas with high concentrations of consumers (Faggiano, 2016). Though they are sometimes combined with fulfillment centers, the two serve different functions. According to MWPVL, the function of sortation centers is to sort and aggregate packages from fulfillment centers by zip code in order to send them to USPS or regional couriers for delivery. This allows Amazon to save costs and deliver on weekends without relying on third party logistics companies (3PLs) UPS and FedEx, which are more expensive (MWPVL, 2016).

Table 5.2: Estimated Amazon Fulfillment & Distribution Network in the US

Facility Type	Active Facilities	Active Square Feet	Future Facilities	Future Square Feet
Fulfillment and Redistribution	76	60,570,100	17	12,381,200
Sortation	26	7,141,900	3	785,000
Prime Now Hubs	42	784,800	-	-
Delivery/Sorting	17	1,323,600	-	-
Total	161	69,820,400	20	13,166,200

Source: MWPVL, 2016

The other two main types of Amazon logistics facilities are delivery stations and Prime Now Hubs. Delivery stations are smaller than sortation centers, at 60,000 to 100,000 square feet, and are also close to metropolitan markets and airports. Their purpose is to prepare outgoing loads of packages for local last mile delivery, and they include specialized, temperature-controlled facilities for Amazon Fresh food deliveries. Prime Now Hubs are small facilities located within metropolitan areas, close to urban centers. They are stocked with limited inventories of popular items, allowing Prime Now customers to receive deliveries in as little as one hour after placing the order (MWPVL, 2016).

Among these facility types, there are further distinctions between types of fulfillment centers, differentiated by the types of products they warehouse. There are also replenishment centers, which receive products from vendors and prepare them for shipment to other fulfillment centers. Returns centers process customer returns (MWPVL, 2016).

In California, Amazon currently has seven fulfillment centers, four of which are in Southern California. Specifically, the company has three fulfillment centers in San Bernardino County, one in Riverside County, one in Stanislaus County, and two in San Joaquin County (Faggiano,

CASE STUDY: AMAZON continued

2016). It was recently reported that two new centers are scheduled to open in Eastvale in the Inland Empire and Tracy in the Bay Area. Both centers will be approximately a million square feet, similar to existing centers, and will employ over 1,500 workers combined (Times, n.d.). Amazon has two sortation centers in California, one in San Bernardino services Southern California, and one in Newark services the Bay Area (MWPVL, 2016).

An interesting aspect of Amazon's fulfillment network is that it allows the company to avoid sales taxes in all but five states, including California. This is because fulfillment centers are considered the location of sale, but they are not retail stores. Thus there is no applicable sales tax requirement in most states (MWPVL, 2016; Faggiano, 2016).

While logistics is a core strength of Amazon's retail model, it is also the source of some of its weaknesses. Amazon's fulfillment operations utilize a large amount of human labor. Target and Amazon have similar topline revenues, and in the 2013 peak season, Amazon had 70,000 temporary workers compared to Target's 50,000 (MWPVL, 2016). Those numbers have risen each year since (Alba, 2015; WSJ, n.d.). In addition, because Amazon's retail volume follows the retail cycle, it is subject to extreme increases during the peak season, which is not an ideal work environment for automation, which tends to require consistency (MWPVL, 2016).

Another weakness is Amazon's reliance on third party logistics providers like UPS and FedEx, which are relatively costly, to handle delivery to customers. In late 2015 and early 2016, Amazon has made moves to directly control and integrate more of its logistics by buying trucks and planes and registering as a non-vessel operating common carrier (NVOCC), which will allow it to organize its own freight forwarding (Szakonyi, 2013). As a NVOCC, Amazon will have a more direct relationship and level of interaction with manufacturers or producers and suppliers, such as in China, where many of the consumer goods are made. Overall, the company is becoming even more of a logistics company and taking greater control over the supply chain.

AMAZON'S IMPLICATIONS FOR EQUITY, SUSTAINABILITY, & COMMUNITY POWER

In terms of the three concepts of social equity, sustainability, and community power, Amazon does not provide a distinct example from other retailers and BCOs. The company has received a considerable amount of negative attention for its workplace culture and practices, including its technology and office workers in its Seattle headquarters in addition to its warehouse workers in Southern California and other parts of the country. Amazon has faced formal accusations, charges, and lawsuits on behalf of warehouse workers over wage and hour

BY THE NUMBERS

230,000+
Full Employees

\$107 Billion
Revenue during FY 2015

4
Fulfillment Centers in Southern CA

4 Million
Square Feet of Fulfillment Centers in Southern CA

Source: Walmart Annual Report, 2016 & Che, 2015

CASE STUDY: AMAZON continued

complaints, working conditions, workplace safety, injuries, and even death (“US Department of Labor’s OSHA cites 5 companies following December 2013 fatality of temporary worker at Amazon fulfillment center in Avenel, NJ,” The company has been the target of numerous class-action lawsuits over the amount of time that warehouse workers must wait to go through required security checks at the end of a shift. Some of the cases have highlighted the company’s use of staffing agencies. In 2014, the Supreme Court ruled against warehouse workers at Amazon who were seeking to be paid for this time (Liptak, 2014; Wasserman, 2014; Chen, 2014).

With regard to warehousing and distribution in the Southern California region, Amazon is known to pay slightly higher than the industry average (Allison, 2016). However, the stratification within its workforce and its reliance on seasonal and temporary labor mean that power remains concentrated at the top, and workers at the lower levels have little ability to change that.

The company has a public statement of Supply Chain Standards (Amazon, n.d.), but it has been largely silent on sustainability (Hardcastle, n.d.; Gunther, 2016). Its outward facing sustainability efforts have focused on packaging (Amazon, n.d.). Its recent move towards vertical integration and having more direct control over its supply chains could mean that it will take more responsibility and exercise more authority over suppliers, producers, and logistics providers. The coming months and years will reveal whether or not Amazon steps up and prioritizes social equity and sustainability for its workers and the communities most impacted by its operations.

With regard to warehousing and distribution in the Southern California region, Amazon is known to pay slightly higher than the industry average (Allison, 2016).

However, the stratification within its workforce and its reliance on seasonal and temporary labor mean that power remains concentrated at the top, and workers at the lower levels have little ability to change that.

SUMMARY OF CASE STUDIES

The case studies solidify that there has been little to no concern for social equity, community power, or sustainability within the logistics industry. An analysis and comparison of these three BCOs through these three lenses can be found on the following page.

SOCIAL EQUITY

It is clear from the case study analysis that three of the industry's largest retailers do not prioritize social equity. The pay gap between Walmart's chief executives and their median workers is extreme. Although Costco and Amazon provide higher wages compared to other large retailers, only a small portion of employees are unionized. While Costco claims that it does not discourage unions, Amazon has actively fought them. Walmart also claims to permit unionization but at the same time has been known to retaliate, terminate, and shut down stores in response to worker organizing efforts.

COMMUNITY POWER

Empowering communities within Southern California that are affected by the negative externalities of the logistics system is also not a top priority of Walmart, Costco, and Amazon. Walmart has a long history of illegally silencing workers who have been calling for better pay and working conditions, at times even firing workers who strike against Walmart's labor policies. It is evident from the Costco and Amazon case studies that they do not take into account a community's needs or visions when building stores or distribution centers, often at the expense of a community's health and livelihood.

SUSTAINABILITY

Literature published by Walmart, Costco, and Amazon can be misleading in the way the BCOs present sustainable policies and procedures. However, upon further analysis it is evident that the three retailers are interested in sustainability from a cost-savings perspective rather than an environmental equity perspective. While Walmart claims to be environmentally responsible, they also aim to save customers money and increase their financial returns at the cost of the environment. Many unfortunate incidents around the world, such as the Bangladesh garment factory fire example, prove that Walmart has taken irresponsible environmental actions to reach their financial goals. While such cases cannot be found in the media for Costco, the retailer's sustainability policies are primarily concerned with cost-saving measures.

THE NEED FOR A JUST TRANSITION

It is clear that if decision-making power remains with BCOs, the retailers will continue to utilize technological advances to cut costs, increase efficiency, and eliminate errors. If the market continues to shape the logistics industry without intervention, current inequities, lack of concern for the community voice, and environmental externalities will continue. Furthermore, these companies are prime examples of the conflict of interest between the environment and capitalist consumption.

To move closer to the vision of a just transition, the following section identifies three recommendations that could be utilized to shift power dynamics given the system as it exists today.

STRATEGIC INTERVENTIONS

FEDERAL PORT POLICIES

Federal port policies should require equitable labor and environmental standards at all US ports. It is evident that POLA and POLB commissioners are hesitant to increase existing labor and environmental regulation due to the fear of losing business to competing ports. National port policies could alleviate this concern by creating a level playing field. New policies could hold BCOs accountable for their negative labor and environmental externalities.

Such regulations could take different forms but should include labor standards that facilitate organizing and collective bargaining for logistics and supply chain workers. Policies should also mitigate pollution from ships and diesel-emitting trucks (Newman, 2012).

Furthermore, federal policies should include a Shared Vessel Agreement (SVA) that mandates that carriers provide data to inform ports of when and in what quantity goods will arrive. Such an agreement, which the Federal Maritime Commission is already proposing, will make data more accessible and usable with the intention of reducing congestion at the ports (Burnson, 2016). A SVA will allow the workers and businesses operating at the ports to more effectively plan for chassis availability, dwell times, container turnaround, and other procedures.

Additionally, this policy should be developed in conjunction with communities that are affected by the logistics system. Community members should be involved in decision-making processes related to the creation and oversight of federal port policies. Environmental justice organizations and labor groups should have seats at the decision-making table.

This intervention requires a national agreement as well as an overseeing body to develop, ratify, and enforce its implementation. The Federal Maritime Commission could extend its oversight to include these responsibilities, though it would also require cooperation from private interests.

TOWARD A JUST TRANSITION

In alignment with the vision of this project for a just transition to a socially equitable and sustainable goods movement system in Southern California, these three strategic interventions seek to redistribute power to communities that are directly affected by the negative externalities of the logistics system.

GLOBAL FAIR TRANSPORT CAMPAIGN

A Fair Transport global campaign would target and pressure producers, suppliers, retailers, and consumers around the globe to support good working conditions and fair pay for all workers in the transportation industries of the goods movement system. This initiative would raise social and political awareness of the negative impacts and externalities caused by logistics-related transportation and generate discourse for possible solutions to the challenges.

Currently, the Fair Transport Europe initiative aims to “improve working conditions for European transport workers” and put the topic on the European Commission’s agenda (Fair Transport Europe, n.d). As a central tool, Fair Transport Europe uses the European Citizens’ Initiative (ECI) to request the European Commission to make the necessary legislative proposals for a more fair transport system.

To promote and build upon Fair Transport Europe, a global collaboration could consist of member campaigns to encourage and increase cooperation around the world. A Fair Transport US campaign would bring the effort home to communities in the US. The tools and strategies of the campaign could include product labeling and scorecards to educate the public and shine a spotlight on logistics practices and their impacts. The campaign could increase community involvement in decision-making in the goods movement system by raising awareness and building alliances with likely partner organizations such as labor unions, environmental justice organizations, research institutions, and other community and regional advocacy groups. This effort would complement the Federal Port Policies proposed above.

To inspire the development of a Fair Transport Campaign in the Southern California region, we propose the following tools and ideas to raise consumer consciousness; see Table 5.2. A committee could be established to rate and certify good practices and employers who meet specified criteria for equity, sustainability, and community involvement. A certification, label, or scorecard could be used to identify responsibly transported products. Producers, suppliers, logistics providers, and retailers who meet the standards of the campaign could use this to promote their products and services.

PRINCIPLES: FAIR TRANSPORTATION STANDARDS

EMPOWERMENT FOR COMMUNITIES & WORKERS

Require transparent and informed decision-making processes that include input from communities located along transportation routes. Allow and encourage labor organizing, specifically transportation industry unions. Require and provide sufficient training regarding workplace safety.

FAIR COMPENSATION

Provide fair wage/salary compensation compatible with job duties, location factors, and associated risks. Wages must be above state and local minimum and adequate to support living in the region.

SOCIAL RESPONSIBILITY

Prohibit the employment of child labor, unsafe working conditions, and overtime without just compensation. Provide good working conditions, fair social rights, and access to healthcare. Require workers’ compensation insurance.

ENVIRONMENTAL SUSTAINABILITY

Compliant with the Clean Truck Program. Prohibit the use of toxic chemicals used in transportation machinery. Practice responsible waste management and actively adopt and integrate new technological advances in helping to decrease and mitigate greenhouse gas emissions.

WORKER ORGANIZING AND CROSS-SECTOR ALLIANCES

Worker groups should build relationships of mutual interest and solidarity across different industries along the supply chain and logistics system. This includes existing unions and worker centers in different types of workplaces and work arrangements as well as new, creative forms of organizing. The changing nature of work, including the fissured workplace and contingent or informal work, combined with changing workforce demographics, demands new strategies and ways to organize. A worker alliance that spans multiple industries, employers, locations, and roles in the supply chain and logistics system could form powerful strategic collaborations to share resources, change policy, and put pressure on bad employers.

This type of alliance could be regional in nature, but it could also be a component of broader level and even international organizing across borders. In a movement for just transition, there are many avenues and various configurations for collaboration, but communities and workers must be organized in order to participate and advocate for themselves.

An element of new organizing recognizes that workers and communities are interdependent and overlapping. Port truckers and longshore workers have two different roles in the supply chain and logistics system, yet many of them are neighbors in the same communities most impacted by logistics-related pollution along transportation routes. A holistic worker organizing approach that recognizes that workers and community members are often one and the same could be transformative for these workers and communities as well as for the regional labor movement.

Bringing these workers together could yield collaborations to shift power at a higher level. In their workplaces, port truckers and longshore workers occupy very different positions of power. While port truckers are fighting

CAL CARTAGE WAREHOUSE WORKERS AND TRUCK DRIVERS ON STRIKE TOGETHER AT PORT OF LOS ANGELES



Source: Warehouse Workers Resource Center, 2016

for their right to be recognized as employees and to organize, longshore workers are represented by the International Longshore and Warehouse Union (ILWU) and enjoy relatively good wages because their role at the ports gives them strategic power. Power relations are not fixed, static, or constant. Building relationships between the ILWU and other workers along the supply chain, including retail workers from the sales floor, warehouse workers, and truckers could lead to new coalitions and a stronger labor movement. At the same time, organizing across and beyond borders with workers in other countries could create the potential for stronger international efforts, especially in port regions that are key to global supply chains.



6

CONCLUSION

SAM APPEL, EVAN MOORMAN, & STEPHANIE TSAI

CHAPTER 6: CONCLUSION

REFLECTIONS

Examining the goods movement system through the framework of social equity, sustainability, and community power has pushed us as students, consumers, residents, community members, and soon-to-be urban planning professionals to consider existential questions about why logistics exists, how it has evolved, where we are heading as a society, and what we value.

Without strategic interventions, the path forward involves expanded highways, ships, TEU volumes, and warehouse facilities. We risk an unsustainable race to the bottom for wages, the environment, and community health. In addition, low-income communities of color will continue to be disproportionately affected by polluted air.

There is another possibility. In this project, we envision an economy and a goods movement system that transitions away from extractive and exploitative consumption and towards social equity, sustainability, and community power. We offer our vision for a world in which worker and community solidarity and public awareness of the fundamental injustices of our economy move us towards a regenerative, locally based economy and racial, economic and gender equity. The strategies to achieve this vision, as detailed in this report, are outlined below.

We conclude by reflecting on our role in creating change. As students of Urban and Regional Planning, we recognize that land use, resource allocation, and the design of communities and cities have the power to reshape urban areas and the lives of the people who reside in them.



STRATEGIC INTERVENTIONS TOWARDS A JUST TRANSITION

The following interventions are a summary of the strategic interventions for a equitable, sustainable goods movement system based on community power. The interventions are organized according to the three research topics (1) regional logistics and global supply chain, (2) the inland port, and (3) transportation technology.

REGIONAL LOGISTICS & THE GLOBAL SUPPLY CHAIN

Federal Port Policies

Federal Port Policies should set standards for equitable work, environmental sustainability, and community involvement in decision-making at all US ports.

Fair Transport Campaign

Advocates should utilize a **Fair Transport Campaign** to raise consumer consciousness about the negative impacts of the logistics system.

Cross-Sector Alliances

Workers and communities should organize together and build **cross-sector alliances** in the region as part of an international movement towards a just transition.

THE INLAND PORT



Align Existing Regulatory Tools

Municipalities should **align existing regulatory tools**, including CBAs, Green Zones, and CalOsha policies, for local implementation in an Environmental Justice Element to minimize harms of warehousing and infrastructure development, and improve jobs.

Goods Movement Oversight Board

The California state legislature should create a **Goods Movement Oversight Board (GoMOB)** similar to the existing Coastal Commission that would assume regional project permitting and planning authority over goods movement development and infrastructure. Board members would be majority community residents and workers to ensure that environmental justice and worker rights at the forefront of decisions.

INTERVENTIONS KEY

-  Social Equity
-  Sustainability
-  Community Power

THE INLAND PORT CONTINUED

Taxes on Industry-Users of Transit Infrastructure

Federal, state and local governments should implement additional **taxes on industry-users of public transportation infrastructure** to offset negative externalities, and allow communities decide how to implement spending plans and mitigations.

Congress should increase current **excise taxes on diesel and tires** to offset current external costs of moving goods incentivize fuel-efficient trucks, and disincentivize heavy loads that damage roads.

Ports should impose a **variable charge on containers** based on weight and distance to be reinvested in road maintenance costs and community health.

Transportation agencies should charge **user-based fees for freight-only corridors** to finance construction and benefits for impacted communities.

Realign Public Investments

Federal, state, regional, and local transportation agencies should **realign public investments** to offer reparations for past harms related to infrastructure and to subsidize transit and sustainable economic development goals.

Reparative public investments should be decided by communities and potentially include local environmental mitigation, local economic development, and local sourcing.



Alternative transportation investments should increase allocations for transit and prioritize creation of a rotating zero-interest loan fund incubator for worker owned co-ops producing transportation-related goods and services.

TRANSPORTATION TECHNOLOGY

Terminal Operator Fines

The Ports should **fine terminal operators** for long total turn-times and give this money back to waiting truckers and the local residential community which suffers from poor air quality caused by excessive idling. The community should define how the funding should be used within certain parameters. The data needed to implement this program will come from GPS sensors that the Ports could mandate for all trucks serving the Ports.

INTERVENTIONS KEY

-  Social Equity
-  Sustainability
-  Community Power

TRANSPORTATION TECHNOLOGY CONTINUED

Flexible PierPass Program

The Ports should encourage a more **flexible PierPass program** in which the GPS sensors on trucks allows for the collection of “big data” on truck movements. This would allow for more demand-based and flexible pricing schemes, which would improve efficiency at the Ports.

Free-Flow Container System

The Ports should continue to encourage **free-flow container systems**. Such systems boost productivity dramatically, but their utilization can necessitate the creation of large container yards for transloading in nearby communities. Thus, the Ports should mandate a per TEU fee on each container and reinvest some of that money back into the community on environmental projects that can mitigate the increased truck trips in the area.

Green Job Training for Displaced Workers & Impacted Communities

Prioritize **green jobs for displaced workers and impacted communities**. The SEED Program, a HUD-affiliated program to increase STEM engagement among low-resourced communities, should also be expanded.

Career Pathways in Sustainable Industries

Leverage public workforce development funds with public-private partnerships to create more **career pathways in sustainable industries**.

Community Benefits Agreements

Regional transportation agencies, including SCAG and Metro, and/or state agencies, including Caltrans, should negotiate **Community Benefits Agreements** as part of regional truck-tollways like the proposed Clean Freight Corridor.



Community & Trucker Inclusion within JPA

Ensure the **inclusion of community groups and truck driver representatives on the Joint Powers Authority (JPA)** that implements the regional network of truck tollways, especially considering the anticipated public subsidy involved with the project.

Clean Trucks 2.0

Clean Trucks 2.0: Implement incentives and mandates to **replace the current fleet of heavy duty diesel trucks with .02 natural gas** engines fueled by renewable natural gas. Ensure that the financial burden does not fall on misclassified truck drivers.

INTERVENTIONS KEY

-  Social Equity
-  Sustainability
-  Community Power

BIBLIOGRAPHY

EXECUTIVE SUMMARY & CHAPTER 1: INTRO

Bensman, D. (2009). Port Trucking Down the Low Road. Demos (July 2009). Retrieved from <http://www.demos.org/sites/default/files/publications/Port%20Trucking%20Down%20the%20Low%20Road.pdf>

Bonacich, E., & Wilson, J. B. (2008). Getting the Goods: Ports, Labor and the Logistics Revolution. Ithaca, N.Y.: Cornell University Press.

City of Los Angeles Harbor Department Planning and Economic Development Division. (2014). Container Terminal Automation (Draft).

Connell, R. (2009, October 20). In City of Industry Business and Governance Converge. LA Times. Retrieved from <http://articles.latimes.com/2009/oct/20/local/me-city-of-industry20>

Coronel, B., Dayaneni, G., Grady-Benson, J., Hayakawa, S., Henson, C., Jones, H., ... Salazar-Dodge, I. (2016). People's Climate March: Reinvestment Toolkit. Climate Justice Alliance.

Garrison, J. (2014, October 15). Warehouse Empire. BuzzFeed. Retrieved from <http://www.buzzfeed.com/jessicagarrison/how-our-shopping-harms-the-lungs-of-california-children>

Giuliano, G., & O'Brien, T. (2007). Reducing port-related truck emissions: The terminal gate appointment system at the Ports of Los Angeles and Long Beach. Transportation Research Part D: Transport and Environment, 12(7), 460–473. <http://doi.org/10.1016/j.trd.2007.06.004>

Gunier, R. B., Hertz, A., von Behren, J., & Reynolds, P. (2003). Traffic density in California: Socioeconomic and ethnic differences among potentially exposed children. Journal of Exposure Science and Environmental Epidemiology, 13(3), 240–246. <http://doi.org/10.1038/sj.jea.7500276>

Hall, S. (1980). Race, Articulation and Societies Structured in Dominance. Sociological Theories: Race and Colonialism, 305–340.

Hayes, J. (2016, May). International Trade, Logistics, and Supply Chain Trends. Presented at the CEE 180 - Transportation Engineering Lecture, UCLA, Boelter Hall.

Inman, F., & Shimoda, C. (2016, April). From Chokepoints to Solutions II. Conference Panel presented at the Southern California Logistics Summit, Fairplex, Pomona.

International Labour Organization. (2015). Guidelines for a just transition towards environmentally sustainable economies and societies for all. International Labour Organization. Retrieved from http://www.ilo.org/wcmsp5/groups/public/---ed_emp/---emp_ent/documents/publication/wcms_432859.pdf

Klein, N. (2014). This changes everything: capitalism vs. the climate.

Mongelluzzo, B. (2015). Teamsters ramp up drayage, warehouse worker organizing effort in LA-Long Beach | Warehouse Worker Resource Center. Journal of Commerce (15307557). Retrieved from <http://www.warehouseworkers.org/teamsters-ramp-up-drayage-warehouse-worker-organizing-effort-in-la-long-beach/>

Newman, P. (2012). Inland Ports of Southern California—Warehouses, Distribution Centers, Intermodal Facilities Impacts, Costs and Trends. Retrieved from <http://caseygrants.org/wp-content/uploads/2012/08/Inland+Ports+of+Southern+California+-+Warehouses+Distribution+Centers+and+Intermodal+Facilities+-+Impacts+Costs+and+Trends.pdf>

Newman, P. (2016, May). Penny Newman Presentation.

Olney, P. (2015, December 14). Where Did the OUR Walmart Campaign Go Wrong? Retrieved from <http://inthesetimes.com/working/entry/18692/our-walmart-union-ufcw-black-friday>

Reliable Prosperity. (n.d.). Social Equity. Retrieved May 29, 2016, from http://www.reliableprosperity.net/social_equity.html

SCAG. (2015). Draft 2016-2040 Regional Transportation Plan/ Sustainable Communities Strategy, December 2015. Southern California Association of Governments. Retrieved from <http://scagrtpscscs.net/Documents/2016/draft/d2016RTPSCS.pdf>

Bonacich, E., & Wilson, J. B. (2008). Getting the Goods: Ports, Labor

and the Logistics Revolution. Ithaca, N.Y.: Cornell University Press.

Coronel, B., Dayaneni, G., Grady-Benson, J., Hayakawa, S., Henson, C., Jones, H., ... Salazar-Dodge, I. (2016). People's Climate March: Reinvestment Toolkit. Climate Justice Alliance.

Hayes, J. (2016, May). International Trade, Logistics, and Supply Chain Trends. Presented at the CEE 180 - Transportation Engineering Lecture, UCLA, Boelter Hall.

International Labour Organization. (2015). Guidelines for a just transition towards environmentally sustainable economies and societies for all. International Labour Organization.

Klein, N. (2014). This changes everything: capitalism vs. the climate.

Reliable Prosperity. (n.d.). Social Equity. Retrieved May 29, 2016, from http://www.reliableprosperity.net/social_equity.html

CHAPTER 2: THE EVOLUTION OF GLOBAL LOGISTICS

Alba, D. (2016a, March 10). Forget Drones: Amazon Is Going to Fly Its Own Planes. WIRED. Retrieved from <http://www.wired.com/2016/03/amazon-going-use-planes-move-merchandise/>

Alba, D. (2016b, April 28). Whoa, Amazon Isn't Just Making Money. It's Making More Than Ever. WIRED. Retrieved from <http://www.wired.com/2016/04/whoa-amazon-isnt-just-making-money-making-ever/>

Amazon. (2015). 2015 Annual Report.

Amazon Distribution Network Strategy. (2016, May). Retrieved May 26, 2016, from http://www.mwpl.com/html/amazon_com.html

AMZN : Summary for Amazon.com, Inc. (n.d.). Retrieved May 26, 2016, from <http://finance.yahoo.com/quote/AMZN/profile?ltr=1>

BIBLIOGRAPHY continued

Barboza, T. (2015, December 14). The Port of L.A. rolled back measures to cut pollution – during its “green” expansion. Los Angeles Times. Retrieved from <http://www.latimes.com/local/california/la-me-port-pollution-20151215-story.html>

Bonacich, E., & Wilson, J. (2008). *Getting the Goods: Ports, labor, and the logistics revolution*. Cornell University Press.

Brennan, E. (2012, September 17). Warehouse Workers to End 50-mile, 6-Day Pilgrimage at LA City Hall, Demand Responsibility from Walmart. Los Angeles County Federation of Labor AFL-CIO.

Clear Air Action Plan. (2016). Retrieved from <http://www.cleanairactionplan.org/about-the-plan/>

Cox, M. (2015, December 27). CMA CGM BENJAMIN FRANKLIN Gets Hollywood Welcome. Maritime Matters.

Cummings, S. L. (2015). Preemptive Strike: Law in the Campaign for Clean Trucks (SSRN Scholarly Paper No. ID 2549949). Rochester, NY: Social Science Research Network.

Dreir, P. (2011, October 9). Moving in the Labor LAANE. New Labor Forum. Retrieved from <http://newlaborforum.cuny.edu/2011/10/09/moving-in-the-labor-laane/>

Edwards, A. (2015, May 22). Port news: ILWU members ratify 5-year labor contract. Press-Telegram. Retrieved from <http://www.presstelegram.com/business/20150522/port-news-ilwu-members-ratify-5-year-labor-contract>

[com/business/20150522/port-news-ilwu-members-ratify-5-year-labor-contract](http://www.presstelegram.com/business/20150522/port-news-ilwu-members-ratify-5-year-labor-contract)

Faggiano, M. (2015, December 29). Where are all Amazon Fulfillment Centers? Retrieved May 26, 2016, from <http://blog.taxjar.com/amazon-warehouse-locations/>

Federal Reserve Bank of St. Louis. (2016). All Employees: Manufacturing. Retrieved May 25, 2016, from <https://research.stlouisfed.org/fred2/series/MANEMP/>

FHWA. (2016). Federal-Aid Highway Program Authorizations Under the Fixing America’s Surface Transportation (FAST) Act. Federal Highway Administration.

GATT. (1986). Retrieved from https://www.wto.org/english/docs_e/legal_e/gatt47.pdf

Greenhouse, S. (2002, November 25). Both Sides See Gains in Deal To End Port Labor Dispute. The New York Times.

KPMG. (2015). Technology Industry Outlook Survey. Retrieved from <http://www.kpmg.com/US/en/industry/technology/Documents/technology-industry-outlook-publication.pdf>

Lapowsky, I. (2015, November 3). Amazon Killed the Bookstore. So It’s Opening a Bookstore. WIRED.

Maskin, E. (n.d.). Globalization Is Increasing Inequality [Text/HTML]. Retrieved May 29, 2016, from <http://www.worldbank.org/en/news/feature/2014/06/23/theorist-eric-maskin-globalization-is-increasing-inequality>

www.worldbank.org/en/news/feature/2014/06/23/theorist-eric-maskin-globalization-is-increasing-inequality

Masunaga, S. (2016, May 25). Amazon will open 2 new California warehouses, in Eastvale and Tracy. The Los Angeles Times.

Mayer, F. W., & Pickles, J. (2010). Re-Embedding Governance: Global Apparel Value Chains and Decent Work (SSRN Scholarly Paper No. ID 1987573). Rochester, NY: Social Science Research Network.

Mongelluzzo, B. (2015, May 23). ILWU-PMA contract no game changer for West Coast productivity. The Journal of Commerce.

Moore, T. (1993). Trucking Deregulation. The Concise Encyclopedia of Economics. Retrieved from <http://www.econlib.org/library/Enc1/TruckingDeregulation.html>

Nanto, D. (2010). Globalized Supply Chains and U.S. Policy. Congressional Research Service. Retrieved from <http://www.lb7.uscourts.gov/documents/14-80031.pdf>

Office of the United States Trade Representative. (n.d.). Free Trade Agreements. Retrieved May 26, 2016, from <https://ustr.gov/trade-agreements/free-trade-agreements>

Olvera, B. (2016, February). ILWU History and Current Circumstances at the Long Beach and Los Angeles Ports. Public Presentation, Los Angeles, CA.

BIBLIOGRAPHY continued

Pacific Maritime Association. (2015). Retrieved from <http://www.pmanet.org/overview>

Page, P. (2016, May 12). Today's Top Supply Chain and Logistics News From WSJ; Delivering up-to-the minute news, analysis, interviews and explanatory journalism on logistics, supply-chain management, e-commerce and more. Wall Street Journal (Online), p. n/a. New York, N.Y.

Panama Canal Authority. (2016). Retrieved from <http://www.panacanal.com/eng/maritime/routes.html>

PierPASS. (2016). Retrieved from <http://www.pierpass.org/about-2/>

Port of Long Beach. (2016). Retrieved from <http://www.polb.com/about/history/>

Polaski, S. (2006, September 11). The Employment Consequences of NAFTA. Retrieved May 25, 2016, from <http://carnegieendowment.org/files/naftawrittentestimony.pdf>

Protecting Big Business. (2016, May 12). Wall Street Journal, Eastern Edition, p. A.14. New York, N.Y.

Pure Earth. (2002). The Hidden Tragedy: Pollution in the Developing World. Black Smith Institute.

SCAG. (2012, April). 2012 Regional Transportation Plan - Goods Movement Appendix. Southern California Association of Governments.

SCAG. (2016, April). 2016 Regional Transportation Plan - Goods Movement Appendix. Southern California Association of Governments.

Schapiro, Mark. (2009). Exposed: The Toxic Chemistry of Everyday Products and What's at Stake for American Power. New York, N.Y.: Chelsea Green Publishing.

Solomon, M. (2016, April 11). Persistently high inventory levels make things tough for retailers, truckers. Supply Chain Quarterly.

Stone, B. (2013). The Everything Store: Jeff Bezos and the Age of Amazon. Little, Brown and Company.
Szakonyi, M. (2013). Amazon's NVOCC status opens door to new business, cheaper rates. Journal of Commerce.

Teamsters. (2016). Retrieved from <https://teamster.org/about>

The Port of Los Angeles. (2016). Retrieved from https://www.portoflosangeles.org/idx_history.asp

Tilly, C. (2014). Disintegrating Democracy at Work: Labor Unions and the Future of Good Jobs in the Service Economy, 43(1), 67–79.

Tomlinson, J. (2009). History and Impact of the Intermodal Shipping Container. Pratt Institute.

Tufano, A. R., Gunnar Trumbull, Peter. (2010). A Brief Postwar History of US Consumer Finance. Harvard Business School - White Paper, 53.

Vernimmen, B., Dullaert, W., & Engelen, S. (2007). Schedule Unreliability in Liner Shipping: Origins and Consequences for the Hinterland Supply Chain. Maritime Economics & Logistics, 9(3), 193–213.

Villarreal, M. (2010). NAFTA and the Mexican Economy. Congressional Research Service. Retrieved from <https://fas.org/sgp/crs/row/RL34733.pdf>

Wade, R. H. (2004). Is Globalization Reducing Poverty and Inequality? World Development, 32(4), 567–589.

Western, B., & Rosenfeld, J. (2011). Unions, Norms, and the Rise in U.S. Wage Inequality. American Sociological Review, 76(4), 513–537.

Winter, J. (1986). 30 Years of Collective Bargaining. Pacific Maritime Association. Retrieved from http://apps.pmanet.org/?cmd=main.category&id_category=58

Wohlsen, M. (2014, June 16). A Rare Peek Inside Amazon's Massive Wish-Fulfilling Machine. WIRED. Retrieved from <http://www.wired.com/2014/06/inside-amazon-warehouse/>

World Shipping Council. (2016). Retrieved from <http://www.worldshipping.org/about-the-industry/history-of-containerization/the-birth-of-intermodalism>

World Trade Organization. (n.d.). Retrieved from https://www.wto.org/english/thewto_e/whatis_e/inbrief_e/inbr01_e.htm

BIBLIOGRAPHY continued

Womack, R. (2006). *The Emergence of Neoliberalism and Free Trade in the Developing World*.

CHAPTER 3: THE INLAND PORT

About Project | Washington Boulevard Construction Project. (n.d.). Retrieved from <http://www.washingtonblvdcommerce.com/about-project/>

Advisory Board | METRANS Transportation Center. (n.d.). Retrieved May 26, 2016, from <https://www.metrans.org/advisory-board>

AFL-CIO Human Resources Development Institute. (1998). *Economic Development: A Union Guide to the High Road*.

Agenda for the City Council of the City of Commerce, § Successor Agency To The Commerce Community Development Commission (2013). Retrieved from <http://www.ci.commerce.ca.us/ArchiveCenter/ViewFile/Item/384>

Allen, N. (2010). Exploring the Inland Empire: Life, Work, and Injustice in Southern California's Retail Fortress. *New Labor Forum*, 19(2), 36–43.

American Lung Association. (2015). *State of the Air 2015*. Retrieved from <http://www.lung.org/local-content/california/documents/sota-2015-fact-sheet-southern-california.pdf>

Assessing Effects of Freight Movement on Air Quality. (n.d.). Retrieved from <http://www.oregon.gov/ODOT/TD/TP/docs/reports/fhwafrrairqualrep1.pdf>

Austin, D. (2015, March). Pricing Freight Transport to Account for External Costs. Congressional Budget Office. Retrieved from http://www.cbo.gov/sites/default/files/114th-congress-2015-2016/workingpaper/50049-Freight_Transport_Working-Paper-2_1.pdf

Barkham, R., & Darin, M. (2016, April). *Trans-Pacific Partnership and Commercial Real Estate: Negotiating the Future of Property Markets*. CBRE. Re

Been, V. (2010). Community Benefits Agreements: A New Local Government Tool or Another Variation on the Exactions Theme? *The University of Chicago Law Review*, 77(1), 5–35.

Belzer, M., Sedo, S., Herzenberg, S., & Swan, P. (n.d.). *Logistics and Transportation*. Keystone Research Center and the Pennsylvania Center for Workforce Information and Analysis.

Benzevi, I. (2016, April). *E-Commerce & Smart Logistics: Transforming the Global and Local Economy*. Presented at the Southern California Logistics Summit, Fairplex, Pomona.

Betancourt, S., & Vallianatos, M. (2010). Storing Harm: The Health and community impacts of goods movement warehousing and logistics. Retrieved from <http://hydra.usc.edu/scehsc/web/Conference%202007/Warehouses%20Issue%20Brief.pdf>

Boehmer, T., Foster, S., Henry, J., Woghiren-Akinnifesi, E., & Yip, F. (2013). *Residential Proximity to Major Highways – United States, 2010 (Morbidity and Mortality Weekly Repor)*. CDC. Retrieved from <https://www.cdc.gov/mmwr/preview/mmwrhtml/su6203a8.htm>

Bonacich, E., & De Lara, J. (2009). *Economic Crisis and the Logistics Industry: Financial Insecurity for Warehouse Workers in the Inland Empire*. Institute for Research on Labor and Employment. Retrieved from <http://escholarship.org/uc/item/8rn2h9ch>

Bonacich, E., & Wilson, J. (2008). *Getting the Goods*. Cornell University Press.

Brennan, E. (2012, September 17). Warehouse Workers to End 50-mile, 6-Day Pilgrimage at LA City Hall, Demand Responsibility from Walmart. Retrieved from <http://launionaflcio.org/2012/12806/warehouse-workers-to-end-50-mile-6-day-pilgrimage-at-city-hall-hundreds-to-greet-marchers-at-la-city-hall-demand-responsibility-from-walmart.html>

Burke, A. Bill Text - AB-2722 Transformative Climate Communities Program., Pub. L. No. Assembly Bill 2722 (2016). Retrieved from https://leginfo.ca.gov/faces/billTextClient.xhtml?bill_id=201520160AB2722

Business Incentives. (n.d.). Retrieved April 27, 2016, from <http://business.ca.gov/RelocateExpand/BusinessIncentives.aspx>

BIBLIOGRAPHY continued

CalEnviroScreen Version 2.0. (2014). Retrieved May 22, 2016, from <http://oehha.ca.gov/calenviroscreen/report/calenviroscreen-version-20>

California Air Pollution Control Officers' Association. (2015). California's Progress Toward Clean Air. Retrieved from <http://www.capcoa.org/wp-content/uploads/2015/04/2015%20PTCA%20CAPCOA%20Report%20-%20FINAL.pdf>

California Coastal Commission. (n.d.). Our Mission. Retrieved May 22, 2016, from <http://www.coastal.ca.gov/whoweare.html>

California Competes Tax Credit. (n.d.). Retrieved April 27, 2016, from <http://business.ca.gov/Programs/CaliforniaCompetesTaxCredit.aspx>

California Environmental Justice Alliance. (2010). Hidden Hazards: A Call to Action for Healthy, Livable Communities (p. English). Retrieved from <http://caleja.org/2015/01/cej-as-2nd-environmental-justice-scorecard/>

California Transportation Commission (CTC): Commissioners. (n.d.). Retrieved May 26, 2016, from <http://www.catc.ca.gov/ctcstaff/members.htm>

Caltrans. (n.d.). Devore Interchange Project - About the Project. Retrieved May 25, 2016, from <http://www.devoreinterchangeproject.com/about-the-project>

CBRE. (2016). Every Penny Counts: How the minimum wage impacts the supply chain (U.S. Industrial and

Logistics ViewPoint). CBRE. Retrieved from <http://www.cbre.us/research/2016-U-S-Reports/Pages/US-Industrial-and-Logistics-ViewPoint.aspx>

Cho, E., Christman, A., Emsellem, M., Ruckelshaus, C., & Smith, R. (2012). Chain of Greed: How Walmart's Domestic Outsourcing Produces Everyday Low Wages and Poor Working Conditions for Warehouse Workers. National Employment Law Project.

Clean Up Green Up. (n.d.). Retrieved May 13, 2016, from <https://cleanupgreenup.wordpress.com/>

Connell, R. (2009, October 20). In City of Industry Business and Governance Converge. LA Times. Retrieved from <http://articles.latimes.com/2009/oct/20/local/me-city-of-industry20>

Coronel, B., Dayaneni, G., Grady-Benson, J., Hayakawa, S., Henson, C., Jones, H., ... Salazar-Dodge, I. (2016). People's Climate March: Reinvestment Toolkit. Climate Justice Alliance.

Crutsinger, M. (2016, April 11). Treasury Secretary Lew: US retreat from global stage would be "worst possible outcome." Retrieved April 26, 2016, from <http://www.usnews.com/news/business/articles/2016-04-11/lew-us-retreat-from-global-economic-stage-would-be-mistake>

Cuajunco, K., & Vanderwarker, A. (2015). Green Zones Across California: Transforming Toxic Hotspots into Healthy Foods. California Environmental Justice Alliance.

Dannenberg, A. L., Frumkin, H., & Jackson, R. (2011). Making healthy places designing and building for health, well-being, and sustainability. Washington, D.C.: Island Press. Retrieved from <http://site.ebrary.com/id/10502945>

David Michaels, Assistant Secretary. (2013, August 21). Temporary Worker Policy Recommendations. OSHA.

De Lara, J. (2013). Warehouse Work: Path to the Middle Class or Road to Economic Insecurity?. Los Angeles, CA: USC Program for Environmental and Regional Equity. Retrieved from http://dornsife.usc.edu/assets/sites/242/docs/WarehouseWorkerPay_web.pdf

Diaz, D. R. (2005). Barrio urbanism: Chicanos, planning, and American cities. New York: Routledge.

Durnin, P., Moler, N., & Harkness, J. (2016). Strong Activity Kicks off 2016 (Inland Empire Industrial, Q1 2016). CBRE.

Economic Analysis Branch Division of Transportation Planning California Department of Transportation. (2015). Transportation Funding in California. Economic Analysis Branch Division of Transportation Planning California Department of Transportation.

Environmental Health Coalition - National City. (n.d.). Retrieved May 13, 2016, from <http://www.environmentalhealth.org/index.php/en/2012-04-18-23-30-57/2012-04-18-23-31-20/national-city>

BIBLIOGRAPHY continued

Environmental Justice Strategy - U.S. Department of Labor - OASP -. (n.d.). Retrieved May 25, 2016, from <https://www.dol.gov/asp/ej/>

Evergreen Cooperatives. (n.d.). Retrieved from <http://www.evgo.com/>

FHWA. (2016a). Federal-Aid Highway Program Authorizations Under the Fixing America's Surface Transportation (FAST) Act. Federal Highway Administration.

FHWA. (2016b, April). A Summary of Highway Provisions - FAST Act. Federal Highway Administration.

Foreign-Trade Zones Board. (n.d.). Retrieved April 27, 2016, from <http://enforcement.trade.gov/ftzpage/index.html>

From Bus Riders Union to Bus Rapid Transit: Race, Class, and Transit Infrastructure in Los Angeles. (2015, May 14). Retrieved May 26, 2016, from <https://www.kcet.org/departures-columns/from-bus-riders-union-to-bus-rapid-transit-race-class-and-transit-infrastructure>

Frumkin, H., Frank, L. D., & Jackson, R. (2004). *Urban sprawl and public health: designing, planning, and building for healthy communities*. Washington, DC: Island Press.

Fryer, D., & Ortiz, P. (2011, October 12). DIR press release. Retrieved May 13, 2016, from <https://www.dir.ca.gov/DIRNews/2011/IR2011-19.html>

Fulton, W. B. (1991). *Guide to California planning*. Point Arena, Calif.: Solano Press Books.

Fulton, W. B. (1997). *The reluctant metropolis: the politics of urban growth in Los Angeles*. Point Arena, CA: Solano Press Books.

Garrison, J. (2014a, October 15). Behind A Huge Bribe, A Tale Of Pollution, Profit, And Economic Transformation. BuzzFeed.

Garrison, J. (2014b, October 15). Warehouse Empire. BuzzFeed.

Gateway Cities. (2014). Retrieved May 29, 2016, from <http://laedc.org/wtc/chooselacounty/regions-of-la-county/gateway-cities/>

Gauderman, W. J., Vora, H., McConnell, R., Berhane, K., Gilliland, F., Thomas, D., ... Peters, J. (2007). Effect of exposure to traffic on lung development from 10 to 18 years of age: a cohort study. *LANCET The Lancet*, 369(9561), 571–577.

Global Access at Southern California Logistics Airport - Home Page. (n.d.). Retrieved May 25, 2016, from <http://www.logisticsairport.com/page.aspx>

Gotham, K. F. (2002). *Race, real estate, and uneven development: the Kansas City experience, 1900-2000*. Albany: State University of New York Press.

Grabell, M. (2013, June 27). The Expendables: How the Temps Who Power Corporate Giants Are Getting Crushed. ProPublica.

Greenhouse, S. (2014, August 31). The Changing Face of Temporary Employment. *The New York Times*.

Gunier, R. B., Hertz, A., von Behren, J., & Reynolds, P. (2003). Traffic density in California: Socioeconomic and ethnic differences among potentially exposed children. *Journal of Exposure Science and Environmental Epidemiology*, 13(3), 240–246.

Harkness, J. (2016). E-commerce drive future of industrial market. CBRE.

Hayes, J. (2016, May). International Trade, Logistics, and Supply Chain Trends. Presented at the CEE 180 - Transportation Engineering Lecture, UCLA, Boelter Hall.

History | MONDRAGON Corporation. (n.d.). Retrieved from <http://www.mondragon-corporation.com/eng/co-operative-experience/history/>

Hricko, A., Rowland, G., Eckel, S., Logan, A., Taher, M., & Wilson, J. (2014). Global Trade, Local Impacts: Lessons from California on Health Impacts and Environmental Justice Concerns for Residents Living near Freight Rail Yards. *International Journal of Environmental Research and Public Health*, 11(2), 1914–1941.

Inman, F., & Shimoda, C. (2016, April). From Chokepoints to Solutions II. Conference Panel presented at the Southern California Logistics Summit, Fairplex, Pomona.

BIBLIOGRAPHY continued

Jamieson, D. (2015). The Life and Death of an Amazon Warehouse Temp. The Huffington Post. Retrieved from <http://highline.huffingtonpost.com/articles/en/life-and-death-amazon-temp/>

Kim JJ, Smorodinsky S, Lipsett M, Singer BC, Hodgson AT, & Ostro B. (2004). Traffic-related air pollution near busy roads: the East Bay Children's Respiratory Health Study. *American Journal of Respiratory and Critical Care Medicine*, 170(5), 520–6.

LA Times. (2015, September 28). In Moreno Valley, profit vs. pollution. Retrieved April 26, 2016, from <http://www.latimes.com/opinion/editorials/la-ed-0928-world-logistics-center-20150928-story.html>

Leyva, C. Bill Text - SB-1000 Land use: general plans: environmental justice., Pub. L. No. Senate Bill 1000 § 65302 (2016).

Lifsher, M. (2012, June 6). Wal-Mart is driving down wages for warehouse workers, report says. Los Angeles Times. Retrieved from <http://launionafcio.org/2012/8777/wal-mart-is-driving-down-wages-for-warehouse-workers-report-says.html>

Lindemann, D., & Britton, D. (2015). Controlled Chaos: Focus Groups with Women Warehouse Workers in New Jersey. Center for Women and Work, Rutgers University.

Loh, P., & Eng, P. (2010). Environmental justice and the green economy: a vision statement and case studies for just and sustainable solutions. Boston, MA: Alternatives for Community and the Environment.

Los Angeles Business Journal. (2016, March 11). Ports of L.A., Long Beach post record cargo volumes in February. Retrieved May 26, 2016, from <http://www.bizjournals.com/losangeles/news/2016/03/11/ports-of-l-a-long-beach-post-record-cargo-volumes.html>

Los Angeles County Board of Supervisors Pass Fully Funded Wage Enforcement Bureau. (n.d.). Retrieved from <http://launionafcio.org/2016/1342504/los-angeles-county-board-of-supervisors-pass-fully-funded-wage-enforcement-bureau.html>

Mohai, P., Lantz, P. M., Morenoff, J., House, J. S., & Mero, R. P. (2009). Racial and Socioeconomic Disparities in Residential Proximity to Polluting Industrial Facilities: Evidence From the Americans' Changing Lives Study. *American Journal of Public Health*, 99(S3), S649–S656.

Mongelluzzo, B. (2015). Teamsters ramp up drayage, warehouse worker organizing effort in LA-Long Beach | Warehouse Worker Resource Center. *Journal of Commerce* (15307557). Retrieved from <http://www.warehouseworkers.org/teamsters-ramp-up-drayage-warehouse-worker-organizing-effort-in-la-long-beach/>

Newman, P. (2012). Inland Ports of Southern California - Warehouses, Distribution Centers, Intermodal Facilities: Impacts, Costs, Trends. Center for Community Action and Environmental Justice.

Newman, P. (2016, May). Penny Newman Presentation.

Occupational Safety and Health Administration (OSHA), & National Institute for Occupational Safety and Health (NIOSH). (2014). Protecting Temporary Workers - Recommended Practices.

Paulson, S. (2003). Southern California Environmental Report Card: Air Pollution. Retrieved from <http://www.environment.ucla.edu/cleanair/pdfs/air-pollution-2003.pdf>

PBP. (n.d.). Examples of PB. Retrieved May 25, 2016, from <http://www.participatorybudgeting.org/about-participatory-budgeting/what-is-pb/>

PERI: The Revival of U.S. Manufacturing. (2010, January). Retrieved April 27, 2016, from <http://www.peri.umass.edu/543/>

Port of Los Angeles. (n.d.). A Cleaner Port. A Brighter Future. Retrieved May 26, 2016, from https://www.portoflosangeles.org/newsroom/2016_releases/news_041216_March_TEUs.asp

Prupis, N., & Lazare, S. (2014). Front-Lines Communities Rising Up: Dispatches from People's Climate. Retrieved May 25, 2016, from <http://www.commondreams.org/news/2014/09/23/front-lines-communities-rising-dispatches-peoples-climate>

Rein, M. (2005). Desert Docks and Octopi: How is ILWU Work Changing and Why? *The Dispatcher*, 63(1), 6–7.

BIBLIOGRAPHY continued

Riverside Avenue Underpass Project at Union Pacific Railroad. (n.d.). Retrieved May 26, 2016, from <http://www.riversideca.gov/publicworks/engineering/gs/riverside.asp>

Riverside County Transportation Commission. (2012). Grade Separation Priority Update Study for Alameda Corridor East (Riverside County).

SANBAG. (2014). Measure I 2010-2040 Ten-Year Delivery Plan. San Bernardino Association of Governments.

SCAG. (2012). 2012 Regional Transportation Plan/ Sustainable Communities Strategy: Environmental Justice Appendix. Southern California Association of Governments.

SCAG (2012b). 2012 Regional Transportation Plan: Highways and Arterials Appendix. Southern California Association of Governments.

SCAG. (2015a). Draft 2016-2040 Regional Transportation Plan/ Sustainable Communities Strategy, December 2015. Southern California Association of Governments.

SCAG. (2015b). Draft 2016 Regional Transportation Plan/ Sustainable Communities Strategy: Goods Movement Appendix. Southern California Association of Governments.

SCAG. (2015c). Draft Regional Transportation Plan/ Sustainable Communities Strategy: Transportation

Finance Appendix. Southern California Association of Governments.

SCAQMD. (2014). Major Air Toxics Study Shows Steep Decline in Cancer Risk to Southland Residents. South Coast Air Quality Management District.

SCAQMD. (2015). Multiple Air Toxics Exposure Study in the South Coast Air Basin (MATES IV). South Coast Air Quality Management District.

Smith, N. (2015, August 4). In California's Inland Empire, an Economic Recovery Brimming With Industrial Complexes. *The New York Times*.

Smog and Health-Historical Info. (n.d.). Retrieved May 26, 2016, from <http://www.aqmd.gov/home/library/public-information/publications/smog-and-health-historical-info>

Struna, J., Curwin, K., Elias, E., Reese, E., Roberts, T., & Bingle, E. (2012). Unsafe and Unfair: Labor Conditions in the Warehouse Industry. *Policy Matters*, 5(2).

The Los Angeles County Federation of Labor, AFL-CIO. (2012). Walmart Warehouse Workers Risk Jobs to Improve Conditions. Retrieved from <http://launionaflcio.org/2012/10443/walmart-warehouse-workers-risk-jobs-to-improve-conditions.html>

The Los Angeles County Federation of Labor, AFL-CIO. (2013a). Fired Warehouse Worker Becomes Leader for Change. Retrieved from <http://launionaflcio.org/2013/120175/fired-warehouse-worker-becomes-leader-for-change.html>

The Los Angeles County Federation of Labor, AFL-CIO. (2013b). Warehouse Workers Strike. Retrieved from <http://launionaflcio.org/2013/221989/warehouse-workers-strike.html>

The Los Angeles County Federation of Labor, AFL-CIO. (2015). Warehouse Workers Can't Take It Any More! Retrieved from <http://launionaflcio.org/2015/1012713/warehouse-workers-cant-take-it-any-more.html>

Transwestern. (2016). Real Estate Outlook: Inland Empire Industrial Market (Real Estate). Transwestern.

US Bureau of Labor Statistics. (2014). Industry Injury and Illness Data [Government]. Retrieved May 13, 2016, from <http://www.bls.gov/iif/oshsum.htm>

US Department of Labor. (n.d.). Temporary Employees. Retrieved May 13, 2016, from <https://www.dol.gov/oasam/doljobs/tempemployees.htm>

Underwood, J. D., & Tomich, M. P. (n.d.). Turning Waste into Vehicle Fuel: Renewable Natural Gas (RNG). Energy Vision. Retrieved from <http://energy-vision.org/ev-publications/EV-RNG-Community-Guide.pdf>

Warehouse Workers United, & Cornelio, D. (2011). Shattered Dreams and Broken Bodies: A Brief Review of the Inland Empire Warehouse Industry. Fontana, CA: Warehouse Workers United.

BIBLIOGRAPHY continued

Washington Blvd Widening and Reconstruction Improvement Project, & Planning and Programming Committee (2014). Retrieved from http://media.metro.net/board/Items/2014/09_september/20140917p&pitem15.pdf

Watt, B. (2015a, October 27). Warehouse workers join port truck drivers on picket line. Southern California Public Radio. Retrieved from <http://www.scpur.org/news/2015/10/27/55278/port-truck-drivers-and-warehouse-workers-strike-to/>

Watt, B. (2015b, December 28). How a 60-acre distribution warehouse could change Compton. Southern California Public Radio. Retrieved from <http://www.scpur.org/news/2015/12/28/56351/as-e-commerce-rises-compton-makes-a-play-for-more/>

Wu J, Houston D, Ong P, Lurmann F, & Winer A. (2009). Exposure of PM2.5 and EC from diesel and gasoline vehicles in communities near the Ports of Los Angeles and Long Beach, California. *Atmos. Environ. Atmospheric Environment*, 43(12), 1962–1971.

Yuan, Q. (2015). Location of Warehouses and Environmental Justice. Retrieved from https://www.mettrans.org/sites/default/files/t3alkingfreight11_18_15qy.pdf

Zeldin, Mel. (2000). Multiple Air Toxics Exposure Study Exposure Study (MATES II) in the South Coast Air Basin. Washington, D.C; Oak Ridge, Tenn.: United States Department of Energy.

Zhu, Y., Hinds, W. C., Kim, S., & Sioutas, C. (2002a). Concentration and Size Distribution of Ultrafine Particles Near a Major Highway. *Journal of the Air & Waste Management Association.*, 52(9), 1032.

Zhu, Y., Hinds, W. C., Kim, S., & Sioutas, C. (2002b). Concentration and Size Distribution of Ultrafine Particles Near a Major Highway. *Journal of the Air & Waste Management Association.*, 52(9), 1032.

CHAPTER 3: INTERVIEWS

Allison, J. (2016, April 18). Interview with Dr. Juliann Allison [Phone].

Husing, J. (2016, April 29). Interview with John Husing [Phone].

Juarez, Z., & Lujan, H. (2016, May 20). Interview with East Yard Communities for Environmental Justice (EYCEJ) [Phone].

Kaosji, S. (2016, April 19). Interview with Sheheryar Kaosji [Phone].

Loveridge, R. (2016, May 5). Interview with Ron Loveridge [Phone].

Nam, A. (2016, May 9). Interview with Annie Nam [Phone].

Wachs, M. (2016, May 18). Interview with Dr. Martin Wachs.

Wolff, G. (2016, May 18). Interview with Goetz Wolff [In Person].

Zatz, N. (2016, May 20). Interview with Noah Zatz [Phone].

CHAPTER 4: TRANSPORTATION TECHNOLOGIES

Addison, B. (2013, February 5). Three Government Committees Reject Current Plans to Widen 710 Between Long Beach and East LA. *Streetsblog Los Angeles*. Retrieved from <http://la.streetsblog.org/2013/02/05/three-government-committees-reject-current-plans-to-widen-710-between-long-beach-and-east-la/>

Aldana, K. (2013, May 30). Press Release: Automated Vehicle Development. National Highway Traffic Safety Administration. Retrieved from <http://www.nhtsa.gov/About+NHTSA/Press+Releases/U.S.+Department+of+Transportation+Releases+Policy+on+Automated+Vehicle+Development>

American Lung Association. (n.d.). State of the Air. Retrieved from <http://www.lung.org/our-initiatives/healthy-air/sota/city-rankings/states/california/los-angeles.html>

BIBLIOGRAPHY continued

- Arcturan Sustainable Cargo. (n.d.). Arcturan Sustainable Cargo Freight Map. Hyperloop One. Retrieved from <https://hyperloop-one.com/global-challenge#>
- Arnstein, S. R. (1969). A Ladder of Citizen Participation. *Journal of the American Institute of Planning*, 35(2), 216–244.
- Beer, T., Grant, T., Williams, D., & Watson, H. (2002). Fuel-cycle greenhouse gas emissions from alternative fuels in Australian heavy vehicles. *Atmospheric Environment*, 36(4), 753–763.
- Bensman, D. (2009). Port Trucking Down the Low Road. Demos (July 2009).
- Bhagat, A., Saphores, J.-D., & Jayakrishnan, R. (2015). Environmental and Health Impacts of Shifting Drayage Truck Operations to Off-peak Hours: An Analysis of the PierPASS Program in Southern California. Presented at the Transportation Research Board 94th Annual Meeting.
- Bhagat, A., Saphores, J.-D., Jayakrishnan, R., & Jung, J. (2014). An Analysis of Air Pollution Impacts from PierPASS in the Alameda Corridor, California. Presented at the Transportation Research Board 93rd Annual Meeting.
- Bucklew, K., & Ogonowski, P. (2015). On a Roll with Tolling. *Planning*, 81(5), pp 39–40.
- Bullard, R. D., & Johnson, G. S. (1997). Just Transportation. In *Just Transportation* (pp. 1–21). Montpelier, Vermont: Capital City Press.
- California Air Resources Board. (2015, November). Draft Technology Assessment: Medium- and Heavy-duty Fuel Cell Electric Vehicles.
- California Air Resources Board. (2016a). BYD Motors in partnership with drayage fleets.
- California Air Resources Board. (2016b). Investment Plan.
- California Air Resources Board. (2016c). Low Carbon Fuel Standard Program | California Air Resources Board. Retrieved May 18, 2016, from <http://www.arb.ca.gov/fuels/lcfs/lcfs.htm>
- California Energy Commission. (2015, December). *renewable.pdf*. Retrieved May 6, 2016, from http://www.energy.ca.gov/renewables/tracking_progress/documents/renewable.pdf
- Callahan, R. F., Pisano, M., & Linder, A. (2010). Leadership and Strategy: A Comparison of the Outcomes and Institutional Designs of the Alameda Corridor and Alameda Corridor East Projects. *Public Works Management & Policy*, 14(3), 263–287.
- Cambridge Systematics Inc., & CH2M HILL. (2009). White Paper# 7: Truck-Only Toll (TOT) Lanes. Oregon Department of Transportation.
- Castello, B. (2015, October). Truck Driver Shortage Analysis. American Trucking Association.
- CH2MHILL. (2014). Automated Container Terminals: Automation of TraPac Terminal, Los Angeles. Presented at the Port Executive Management Seminar, Merida, Mexico.
- City of Los Angeles Harbor Department Planning and Economic Development Division. (2014). Container Terminal Automation (Draft).
- Clabrun, T. (2015, May 7). First Automated Truck Licensed To Operate On Public Roads. Retrieved from <http://www.informationweek.com/mobile/mobile-business/first-automated-truck-licensed-to-operate-on-public-roads/d/d-id/1320311>
- De Palma, A., Kilani, M., & Lindsey, R. (2008). The merits of separating cars and trucks. *Journal of Urban Economics*, 64(2), 340–361.
- Dines, R. (2013, September 25). \$85 Million Added To Port Of Long Beach's Middle Harbor Price Tag. *Longshore & Shipping News*.
- Downs, A. (2005). Still stuck in traffic: coping with peak-hour traffic congestion. Brookings Institution Press.
- Eisenstein, P. (2016, April 7). Autonomous and Self-Driving Trucks Will Improve Safety, Fuel Economy. Trucks.com.

BIBLIOGRAPHY continued

FHWA. (2016a). Federal-Aid Highway Program Authorizations Under the Fixing America's Surface Transportation (FAST) Act. Federal Highway Administration.

Fields, G., Hartgen, D., Moore, A., & Poole Jr, R. W. (2009). Relieving congestion by adding road capacity and tolling. *International Journal of Sustainable Transportation*, 3(5-6), 360–372.

Fischer, M., Ahanotu, D., & Waliszewski, J. (2003). Planning truck-only lanes: Emerging lessons from the Southern California Experience. *Transportation Research Record: Journal of the Transportation Research Board*, (1833), 73–78.

Giuliano, G., & O'Brien, T. (2008). Extended gate operations at the ports of Los Angeles and Long Beach: a preliminary assessment. *Maritime Policy & Management*, 35(2), 215–235.

Giuliano, G., O'Brien, T., Deblanc, L., & Holliday, K. (2013). *Synthesis of Freight Research in Urban Planning* (No. NCFRP Report 23) (pp. 1–98). Washington, D.C.: Transportation Research Board.

Gladstein, Neandross & Associates. (2016). *Game Changer: NEXT GENERATION HEAVY DUTY NATURAL GAS ENGINES FUELED BY RENEWABLE NATURAL GAS*.

Golob, T., F., & Regan, A. C. (2001). Impacts of highway congestion on freight operations: perceptions of trucking industry managers. *Transportation Research Part A: Policy and Practice*, 35(8), 577–599.

Google Self-Driving Car Project Monthly Report. (2016). Retrieved from <https://static.googleusercontent.com/media/www.google.com/lt/selfdrivingcar/files/reports/report-0316.pdf>

Greenhouse, S. (2010). Clearing the Air at American ports. *New York Times B*, 1. Retrieved from http://www.teamsters952.org/Clearing_the_Air_at_American_Ports_-_NYTimes.com.pdf

Gruenberg, M. (2015, December 31). L.A. port truckers win again, misclassified as independent contractors. Retrieved from <http://peoplesworld.org/l-a-port-truckers-win-again-misclassified-as-independent-contractors/>

Guerrini, F. (2015, January 31). Will Technology Make Truck Drivers Obsolete In 10 Years? Retrieved from <http://www.forbes.com/sites/federicoguerrini/2015/01/31/technology-is-going-to-make-truck-drivers-obsolete-in-a-decade-report-says/#606c89bc7815>

Hall, E. (2016, May 11). Hyperloop One shows us how fast we'll get from here to there. Retrieved May 23, 2016, from <http://www.cnet.com/news/hyperloop-one-shows-us-how-fast-well-get-from-here-to-there/>

Hayes, J. (2016, May). *International Trade, Logistics, and Supply Chain Trends*. Presented at the CEE 180 - Transportation Engineering Lecture, UCLA, Boelter Hall.

Hirsch, J. (2016, April 6). Trucking "Uber" Start-up Cargomatic Slashes Staff. *Trucks.com*. Retrieved

from <https://www.trucks.com/2016/04/06/trucking-uber-start-up-cargomatic-slashes-staff/>

Houston, D., Krudysz, M., & Winer, A. (2008). Diesel Truck Traffic in Low-Income and Minority Communities Adjacent to Ports: Environmental Justice Implications of Near-Roadway Land Use Conflicts. *Transportation Research Record: Journal of the Transportation Research Board*, 2067, 38–46.

Hricko, A. (2008). Global Trade Comes Home: Community Impacts of Goods Movement. *Environmental Health Perspectives*, 116(2), 78–81.

Hricko, A., Rowland, G., Eckel, S., Logan, A., Taher, M., & Wilson, J. (2014). Global Trade, Local Impacts: Lessons from California on Health Impacts and Environmental Justice Concerns for Residents Living near Freight Rail Yards. *International Journal of Environmental Research and Public Health*, 11, 1914–1941.

Husing, J. (2016). Inland Empire Job Quality 2011-2015. *Inland Empire Quarterly Economic Report*, VOL. 27 NO.1.

Hyperloop One. (n.d.). Hyperloop to collaborate on high-speed transportation system. Retrieved May 23, 2016, from <http://www.railway-technology.com/news/newsglobal-partnership-develop-high-speed-hyperloop-system-4891381>

Hyperloop One Global Challenge. (n.d.). Retrieved May 23, 2016, from <https://hyperloop-one.com/global-challenge>

BIBLIOGRAPHY continued

I-710 Corridor Project EIR/EIS Alternative 7. (2014, May 8). Metro.

International Labour Organization. (2015). Guidelines for a just transition towards environmentally sustainable economies and societies for all. International Labour Organization.

Killough, K., L. (2008). Value Analysis of Truck Toll Lanes in Southern California. Presented at the Transportation Research Board 87th Annual Meeting, Washington, D.C.: Transportation Research Board.

Leachman, R. C., Prince, T., Directions, S., & George, R. F. (2005). Port and modal elasticity study. Citeseer.

Meyer, M., Saben, L., Shephard, W., & Stevens, E. (2006). Feasibility of Truck-Only Toll Lane Network in Atlanta, Georgia. Transportation Research Record: Journal of the Transportation Research Board, 1960, 57–67.

Monaco, K., & Grobar, L. (2005). A study of drayage at the Ports of Los Angeles and Long Beach. METTRANS Transportation Center.

Mongelluzzo, B. (2015, May 2). New automated Rotterdam container terminal shows how far US lags | JOC.com. Retrieved May 29, 2016, from http://www.joc.com/port-news/terminal-operators/apm-terminals/new-automated-rotterdam-container-terminal-shows-just-how-far-us-lags_20150502.html

Morais, P., & Lord, E. (2006, March). Terminal Appointment System Study. Program of Energy

Research and Development (PERD) of Natural Resources Canada (NRCan).

Morris, D. (2015, May 19). In trucking, a little automation saves a lot of money. Retrieved from <http://fortune.com/2015/05/19/trucking-automation/>

Musk, E. (2013, August 12). Hyperloop Alpha.

Neandross, E. (2016, February). Game Changer: Reducing Energy Consumption, Carbon Emissions, and Criteria Pollutants from Heavy-Duty Vehicles. Gladstein, Neandross & Associates.

One, H. (2016, May 11). Hyperloop One Builds A Growing Network Of Global Partners To Pursue New Opportunities. Retrieved May 23, 2016, from <http://www.prnewswire.com/news-releases/hyperloop-one-builds-a-growing-network-of-global-partners-to-pursue-new-opportunities-300266716.html>

Park, J. (2012, January 18). Driver Shortage is a Myth. Retrieved from <http://www.truckinginfo.com/blog/on-the-road/story/2012/01/the-driver-shortage-is-a-myth.aspx>

Petersen, R. (2015, September 22). Why Is the Port of Rotterdam More Automated Than Oakland? Retrieved May 24, 2016, from <https://www.flexport.com/blog/port-automation-oakland-rotterdam/>

Petrilla, John, Sato, Kenji, & Sywak, Andy. (2009). 62008 - Clean Trucks Program.pdf. UCLA School of Public Affairs. Retrieved from http://164.67.121.27/files/Lewis_Center/

publications/studentreports/62008%20-%20Clean%20Trucks%20Program.pdf

PierPASS. (n.d.). Retrieved from <http://www.pierpass.org/>

Poole, R. W. (2007). The case for truck-only toll lanes. Public Works Management & Policy, 11(4), 244–249.

Port of Long Beach - Middle Harbor. (n.d.). Retrieved May 26, 2016, from <http://www.polb.com/about/projects/middleharbor.asp>

Port of Los Angeles. (2014). Port of Los Angeles Air Emissions Inventory Full Report.

Rainey, J. (2014, March 21). Port truck drivers vying to join union get state, federal boost. Retrieved from <http://www.latimes.com/local/lanow/la-me-ln-port-truck-drivers-union-20140321-story.html>

REBECCA SMITH PAUL ALEXANDER MARVY JON ZEROLNICK. (2014). The Big Rig Overhaul. Retrieved from <http://www.laane.org/wp-content/uploads/2014/02/BigRigOverhaul2014.pdf>

Regan, A. C., & Golob, T. F. (2000). Trucking industry perceptions of congestion problems and potential solutions in maritime intermodal operations in California. Transportation Research Part A: Policy and Practice, 34(8), 587–605.

Samuel, P., Poole, R. W., & Holguin-Veras, J. (2002). Toll truckways: A new path toward safer and more efficient freight transportation. Reason Public Policy Institute.

BIBLIOGRAPHY continued

Sanchez, T., Stolz, R., & Ma, J. (2003). *Moving to Equity: Addressing Inequitable Effects of Transportation Policies on Minorities*. Cambridge, MA: The Civil Rights Project at Harvard University.

SCAG. (2004). *2004 Regional Transportation Plan: Goods Movement Appendix*. Southern California Association of Governments.

SCAG. (2012). *2012 Regional Transportation Plan/Sustainable Communities Strategy: Transportation Finance Appendix*. Southern California Association of Governments.

SCAG. (2016). *Draft 2016 Regional Transportation Plan/ Sustainable Communities Strategy: Goods Movement Appendix*. Southern California Association of Governments.

SCAQMD. (2014). *Air Quality Management Plan*. South Coast Air Quality Management District.

SCAQMD. (2016, January). *2016 Air Quality Management Plan Fact Sheet*. South Coast Air Quality Management District.

SCAQMD. (2015). *Multiple Air Toxics Exposure Study in the South Coast Basin*. South Coast Air Quality Management District.

SCAQMD. (n.d.). *Historic Ozone Air Quality Trends*. South Coast Air Quality Management District.

Silver-Pacuilla, H. (n.d.). *Engaging in STEM Where We Live*. Retrieved May 26, 2016, from <http://sites.ed.gov/octae/2016/05/16/engaging-in-stem-where-we-live/>

ed.gov/octae/2016/05/16/engaging-in-stem-where-we-live/

Sorensen, P., Wachs, M., Min, E., Y., Kofner, A., Ecola, L., Hanson, M., ... Griffin, J. (2008). *Moving Los Angeles: Short-Term Policy Options for Improving Transportation*. Santa Monica, CA: RAND Corporation.

Sullivan, E. (2002). *State Route 91 Value-Priced Express Lanes: Updated Observations*. *Transportation Research Record: Journal of the Transportation Research Board*, 1812, 37–42.

Sustainable Freight Transport Initiative. (n.d.). Retrieved May 11, 2016, from <http://www.arb.ca.gov/gmp/sfti/sfti.htm>

The Port of Los Angeles. (2014, June). *Port of Los Angeles: America's Port*. Presented at the Future Ports - Annual Conference, San Pedro, California.

Thornton, D., Kagan, R. A., & Gunningham, N. (2008). *Compliance costs, regulation, and environmental performance: Controlling truck emissions in the US*. *Regulation & Governance*, 2(3), 275–292.

U.S. EPA. (2016, February). *Third Report to Congress: Highlights from the Diesel Emission Reduction Program*.

Voß, S., Stahlbock, R., & Steenken, D. (2004). *Container terminal operation and operations research - a classification and literature review*. *OR Spectrum*, 26(1), 3–49.

Walmart's Truck Fleet. (n.d.). Retrieved May 26, 2016, from <http://corporate.walmart.com/global-responsibility/environment-sustainability/truck-fleet>

Werner, M., Eissing, K., & Langton, S. (2016, May 11). *Shared Value Potential of Transportation Cargo via Hyperloop*. Helmut Schmidt University, Hamburg.

W.G. Wang, D.W. Lyons, N. N. Clark, and M. Gautam. (n.d.). *Emissions from Nine Heavy Trucks Fueled by Diesel and Biodiesel Blend without Engine Modification*.

Yan, W., Zhu, Y., & He, J. (2014). *Performance Analysis of a New Type of Automated Container Terminal*. *International Journal of Hybrid Information Technology*, 7(2), 237–248.

Yoh, A. (2016, April). *Investing in Freight: Creative Funding for Port Infrastructure*. UCLA Luskin School of Public Affairs.

Ziegler, C. (2016, May 17). *Google veterans head off on their own to work on self-driving trucks*. Retrieved from <http://www.theverge.com/2016/5/17/11686912/otto-self-driving-semi-truck-startup>

CHAPTER 4: INTERVIEWS

Anonymous. (2016, May 11). *Interview re: Clean Trucks Program, Trucker Misclassification, and Politics at the Ports*.

BIBLIOGRAPHY continued

Anonymous Port Truck Drivers. (2016, May 24). Interview with Three Anonymous Port Truck Driver: Port Trucking and the Current Terminal Appointment System [Phone].

Husing, J. (2016, April 29). Interview with John Husing: Economic Impacts of Automation Technology [Phone].

Nam, A. (2016, May 9). Interview Annie Nam: Goods Movement and Transportation Finance.

Neandross, E. (2016, April 27). Interview re: Clean Truck Technologies.

Santamaria, C. (2016, May). Interview re: Trucker Misclassification.

Stewart, M., & Patil, S. (2016, April 21). Interview with Michelle Stewart and Shashank Patil, PierPASS and Traffic Management at the Ports.

Wachs, M. (2016, May 18). Interview with Martin Wachs: Infrastructure Financing and Public Participation.

CHAPTER 5: CASE STUDIES OF THREE MAJOR PLAYERS

Alba, D. (2015, October 20). Amazon Is Hiring a Bonkers Number of Temps This Holiday. WIRED.

Alba, D. (2016a, March 10). Forget Drones: Amazon Is Going to Fly Its Own Planes. WIRED.

Alba, D. (2016b, April 28). Whoa, Amazon Isn't Just Making Money. It's Making More Than Ever. WIRED.

Amazon. (2015). 2015 Annual Report.

Amazon. (n.d.). Supply Chain Standards. Retrieved May 30, 2016, from <http://www.amazon.com/gp/help/customer/display.html?nodeId=200885140>

Amazon.com: Amazon & Our Planet. (n.d.). Retrieved May 30, 2016, from <http://www.amazon.com/b?node=13786321>

Amazon.com Investor Relations: Press Release. (n.d.). Retrieved May 26, 2016, from <http://phx.corporate-ir.net/phoenix.zhtml?c=97664&p=irol-newsArticle&ID=2162972>

Amazon Distribution Network Strategy. (2016, May). Retrieved May 26, 2016, from http://www.mwpl.com/html/amazon_com.html

Amazon to Hire 100,000 U.S. Workers for Holidays - WSJ. (n.d.). Retrieved May 30, 2016, from <http://www.wsj.com/articles/amazon-to-hire-100-000-u-s-workers-for-holidays-1445320512>

AMZN: Summary for Amazon.com, Inc. (n.d.). Retrieved May 26, 2016, from <http://finance.yahoo.com/quote/AMZN/profile?ltr=1>

Anonymous. (2016, May 12). Protecting Big Business. Wall Street Journal, Eastern Edition, p. A.14. New York, N.Y.

Baldwin, R. E., & Winters, L. A. (2007). Challenges to Globalization: Analyzing the Economics. University of Chicago Press.

Bonacich, E., & Wilson, J. B. (2008). Getting the Goods: Ports, Labor and the Logistics Revolution. Ithaca, N.Y.: Cornell University Press.

Burnson, P. (2016, April 6). Vessel-sharing agreements deserve added scrutiny. Retrieved from http://www.logisticsmgmt.com/view/vessel_sharing_agreements_deserve_added_scrutiny/ports_and_infrastructure

Chan, A. (2011). Walmart in China. Cornell University Press.

Che, J. (2015, August 27). Here's How Outrageous The Pay Gap Between CEOs And Workers Is. The Huffington Post.

BIBLIOGRAPHY continued

Chen, M. (2014, October 10). Supreme Court Case Shows How Amazon Legally Cheats Workers. The Nation.

Costco Wholesale. (2015). Costco Wholesale Sustainability Report.

Costco Wholesale Corporate Profile. (2016). Retrieved from <http://phx.corporate-ir.net/phoenix.zhtml?c=83830&p=irol-homeprofile>

Costco Wholesale Costco Disclosure. (2016). Retrieved from <http://www.costco.com/disclosure-regarding-human-trafficking-and-anti-slavery.html>

Costco Wholesale Kirkland Signature. (2016). Retrieved from <http://www.costco.com/kirkland-signature.html>

Costco Wholesale Supplier Diversity. (2016). Retrieved from <http://www.costco.com/supplier-diversity.html>

De Lara, J. (2013). Warehouse Work: Path to the Middle Class or Road to Economic Insecurity? USC Program for Environmental and Regional Equity.

Dranow, A. (2014, November 5). 6 Ways Walmart Made its Mark in Retail History. Retrieved May 16, 2016, from http://blog.walmart.com/_blog_/heritage/20141105/6-ways-walmart-made-its-mark-in-retail-history

Faggiano, M. (2015, December 29). Where are all Amazon Fulfillment Centers? Retrieved May 26, 2016, from <http://blog.taxjar.com/amazon-warehouse-locations/>

Fox, E. J. (2013, May 1). Americans face tough choices over Bangladesh. Retrieved May 23, 2016, from <http://money.cnn.com/2013/05/01/news/companies/bangladesh-garment-factory/index.html>

Gunther, M. (2016, February 2). Can Amazon's new "dream team" fix the company's sustainability reputation? Retrieved May 30, 2016, from <http://www.theguardian.com/sustainable-business/2016/feb/02/amazon-sustainability-edf-epa-best-buy-walmart-apple-microsoft-csr-child-labor>

Hall, S. (2016, May). Costco Mira Loma Depot 960. Costco Mira Loma Depot 960.

Hardcastle, J. L. (n.d.). Is Amazon Getting a Sustainability Makeover? Environmental Leader · Environmental Management News.

International Labour Organization. (2015). Guidelines for a just transition towards environmentally sustainable economies and societies for all. International Labour Organization.

Is Wal-Mart Good for America? (2004, November 16). Public Broadcasting Service (PBS). Retrieved from <http://www.pbs.org/wgbh/frontline/film/showswalmart/>

Jamieson, D. (2015). The Life and Death of an Amazon Warehouse Temp. The Huffington Post.

Kulwiec, R. (2004). Crossdocking as a Supply Chain Strategy By reducing reliance on inventory buffers and expediting customer orders, crossdocking promotes a flow-through supply-chain pipeline. Retrieved May 16, 2016, from http://www.ame.org/sites/default/files/target_articles/04-20-3-Crossdocking.pdf

Lapowsky, I. (2015, November 3). Amazon Killed the Bookstore. So It's Opening a Bookstore. WIRED.

LEUNG, L. (n.d.). Amazon increasing foothold in Southern California with new warehouse. Retrieved May 30, 2016, from <http://www.oregister.com/articles/amazon-631748-state-new.html>

Levine-Weinberg, A. (2016, March 19). Even Costco Has Union Problems!: Costco may pay more than its retail competitors, but the Teamsters union is gearing up for a fight over retirement benefits. The Motley Fool.

Liptak, A. (2014, December 9). Supreme Court Rules Against Worker Pay for Screenings in Amazon Warehouse Case. The New York Times. Retrieved from <http://www.nytimes.com/2014/12/10/business/supreme-court-rules-against-worker-pay-for-security-screenings.html>

BIBLIOGRAPHY continued

MWPVL. (n.d.). The Walmart Distribution Center Network in the United States. Retrieved May 16, 2016, from <http://www.mwpvl.com/html/walmart.html>

Newman, P. (2012). Inland Ports of Southern California – Warehouses, Distribution Centers, Intermodal Facilities Impacts, Costs and Trends. Center for Community Action and Environmental Justice.

Newman, P. (2016, May). Inland Empire Presentation. Center for Community Action and Environmental Justice.

Page, P. (2016, May 12). Today's Top Supply Chain and Logistics News From WSJ; Delivering up-to-the minute news, analysis, interviews and explanatory journalism on logistics, supply-chain management, e-commerce and more. Wall Street Journal (Online), p. n/a. New York, N.Y.

Rosenblum, P. (2014, May 22). How Walmart Could Solve Its Inventory Problem And Improve Earnings. Retrieved May 16, 2016, from <http://www.forbes.com/sites/paularosenblum/2014/05/22/walmart-could-solve-its-inventory-problem-and-improve-earnings/>

Sam Walton. (2008, October 9). Retrieved May 16, 2016, from <https://www.entrepreneur.com/article/197560>

Sethi, S. P. (2013, May 8). The World of Wal-Mart. Retrieved May 23, 2016, from <http://>

www.carnegiecouncil.org/publications/ethics_online/0081

Soni, P. (2015, February 20). Managing Walmart's Supply Chain – Cross-Docking and Other Tools. Retrieved May 16, 2016, from <http://finance.yahoo.com/news/managing-walmart-supply-chain-cross-230540171.html>

Soni, P. (2016). Investing in Costco The U.S.'s Largest Warehouse Club Operator: How Costco manages Inventory and supply chain. Market Realist.

Stone, B. (2013a). The Everything Store: Jeff Bezos and the Age of Amazon. Little, Brown and Company.
Stone, B. (2013b, June 7). Costco CEO Craig Jelinek Leads the Cheapest, Happiest Company in the World. Bloomberg.

Szakonyi, M. (2013). Amazon's NVOCC status opens door to new business, cheaper rates. Journal of Commerce.

Times, L. A. (2016, May 25). Amazon will open 2 new California warehouses, in Eastvale and Tracy. The Los Angeles Times.

US Department of Labor's OSHA cites 5 companies following December 2013 fatality of temporary worker at Amazon fulfillment center in Avenel, NJ. (2014, June 12). U.S. Department of Labor Office of Public Affairs.

Wal-Mart Stores, Inc. (2016). Walmart 2016 Annual Report (Annual) (p. 68). Bentonville, Arkansas 72716

Wasserman, S. (2014, July 16). When Will the Justice Department Take On Amazon? The Nation.

Wohlsen, M. (2014, June 16). A Rare Peek Inside Amazon's Massive Wish-Fulfilling Machine. WIRED.

WTO | About the organization. (n.d.). Retrieved May 16, 2016, from https://www.wto.org/english/thewto_e/thewto_e.htm

Wulfraat, M. (2014). The secret to Costco's success lies in supply chain efficiency. Canadian Grocer.

Yardley, J. (2012, December 6). Bangladesh Fire Exposes Safety Gap in Supply Chain. The New York Times.

CHAPTER 5: INTERVIEWS

Allison, J. (2016, April 18). Interview with Dr. Juliann Allison [Phone].

Anonymous. (2016, May 11). Interview with Anonymous: Clean Trucks Program, Trucker Misclassification, and Politics at the Ports.

Hesketh, P. (2016, April 28). Interview with Peter Hesketh.

Neandross, E. (2016, April 27). Interview with Erik Neandross: Clean Truck Technologies.

Santamaria, C. (2016, May). Interview Carlos Santamaria, Teamster: Trucker Misclassification.

BIBLIOGRAPHY continued

GLOSSARY

Air Resources Board. (n.d.). Drayage Truck Regulation. Retrieved May 30, 2016, from <http://www.arb.ca.gov/msprog/onroad/porttruck/2027regfinal.pdf>

Bank of America. (n.d.). Investment Terms Glossary. Retrieved May 30, 2016, from http://www.bofam.com/content/dam/boamlimages/documents/articles/B2_014/b2_014_investmenttermsglossary.pdf

CalEnviroScreen Version 2.0. (2014). Retrieved May 22, 2016, from <http://oehha.ca.gov/calenviroscreen/report/calenviroscreen-version-20>

Cuajunco, K., & Vanderwarker, A. (2015). Green Zones Across California: Transforming Toxic Hotspots into Healthy Foods. California Environmental Justice Alliance.

Gateway Cities. (2014). Retrieved May 29, 2016, from <http://laedc.org/wtc/chooselacounty/regions-of-lacounty/gateway-cities/>

Harvey, D. (2005). A Brief History Neoliberalism. Retrieved from <http://www.sok.bz/web/media/video/ABriefHistoryNeoliberalism.pdf>

Lee, E., & others. (2005). Trade Liberalization and Employment. UN. Retrieved from http://www.un.org/esa/wp5_2005.pdf

Loh, P., & Eng, P. (2010). Environmental justice and the green economy: a vision statement and case studies for just and sustainable solutions. Boston, MA: Alternatives for Community and the Environment.

Narea, N. (2015, July 23). Square, LevelUp, Shopkeep: A Small Business Guide to Mobile Point-Of-Sale Systems. Forbes.

Prupis, N., & Lazare, S. (2014). Front-Lines Communities Rising Up: Dispatches from People's Climate. Retrieved May 25, 2016, from <http://www.commondreams.org/news/2014/09/23/front-lines-communities-rising-dispatches-peoples-climate>

Reliable Prosperity. (n.d.). Social Equity. Retrieved May 29, 2016, from http://www.reliableprosperity.net/social_equity.html

University of Michigan. (2016). International Economics Glossary: G. Retrieved May 30, 2016, from <http://www-personal.umich.edu/~alandear/glossary/g.html>

PHOTO & IMAGE CREDITS

FRONT COVER

Port of Los Angeles, photograph by Diana Benitez

INTRODUCTION TITLE PAGE

POLA & POLB Truckers on strike, photograph by Steve McCrank for the Associated Press

CHAPTER 2 TITLE PAGE

Port of Los Angeles, photograph by Diana Benitez

CHAPTER 3 TITLE PAGE

Warehouses adjacent to residential land uses, photograph by Jesse Kaplan for BuzzFeed News

CHAPTER 4 TITLE PAGE

TraPac Automated Terminal at the Port of Los Angeles, photograph by Kate Bridges

CHAPTER 5 TITLE PAGE

Costco Mira Loma Depot, photograph by Goetz Wolff

CHAPTER 6 TITLE PAGE

Port of Los Angeles, photograph by Diana Benitez

APPENDIX TITLE PAGE

Community Scholars 2016 cohort, photograph by Goetz Wolff



APPENDIX: Glossary, Acronyms, & Biographies

Delivering the Good: Strategic Interventions Towards a Just and Sustainable Logistics System in Southern California

GLOSSARY

CLEANER FUELS A term referring to the group of alternative fuels that have a lesser carbon footprint, particularly when compared to fossil fuels. Cleaner fuels are classified by the U.S. Department of Energy and the Energy Policy Act of 1992 (U.S. DOE, 2016).

CLIMATE CHANGE A term used to refer to all forms of climatic inconsistency, but especially to significant change from one prevailing climatic condition to another. In some cases, “climate change” has been used synonymously with the term “global warming”; scientists, however, tend to use the term in a wider sense inclusive of natural changes in climate, including climatic cooling (U.S. Energy Information Administration, 2016).

COMMUNITY POWER refers to the influence that communities have over goods movement-related activities and decisions in their neighborhoods. Community power constitutes a goal of self-advocacy and self-determination for the people most severely affected by goods movement activities.

COMPETITIVENESS & COMPARATIVE ADVANTAGE

Competitiveness Characteristics that permit a firm to compete effectively with other firms due to low cost, superior technology, and/or aggressive marketing, perhaps internationally (University of Michigan, Ann Arbor Alan Deardorff, Gerald Ford School of Public Policy, International Economics, 2016).

Comparative advantage The ability to produce a good at lower cost, *relative* to other goods, compared to another country. With perfect competition and undistorted markets, countries tend to export goods in which they have comparative advantage (University of Michigan, Ann Arbor Alan Deardorff, Gerald Ford School of Public Policy, International Economics, 2016).

DIESEL PARTICULATE MATTER The amount of diesel particulates in the air from on-road and non-road sources, measured in kg/day. In this report, this diesel particulate matter is usually measured with a spatial distribution of gridded diesel emissions (CalEnviroScreen Version 2.0, 2014).

DRAYAGE The transport of goods over a short distances, often as part of a longer overall move, and typically completed in a single work shift. The term is often used to describe the movement of cargo between a seaport and an interior area or inland port.

FREE TRADE ZONE refers to an area where import tariffs and export levies are not applied.

FRONT LINE COMMUNITIES are communities that suffer disproportionately from environmental degradation. In the context of this report, the term will be used to describe the those communities suffering most directly from the air, light, and sound pollution associated with the Ports (Coronel et al., 2016; Prupis & Lazare, 2014).

GATEWAY CITIES This Los Angeles County region covers the 27 industrial and manufacturing-based cities in the southeast of Los Angeles County. These cities include: Artesia, Avalon, Bell, Bell Gardens, Bellflower, Catalina Island, Cerritos, Commerce, Compton, Cudahy, Downey, Hawaiian Gardens, Huntington Park, La Habra Heights, La Mirada, Lakewood, Long Beach, Lynwood, Maywood, Montebello, Norwalk, Paramount, Pico Rivera, Santa Fe Springs, Signal Hill, South Gate, Vernon, and Whittier (“Gateway Cities,” 2014).

GLOBALIZATION A term used to refer to the world-wide integration of markets for goods, services and capital that has become increasingly common since the 1970s and 1980s. It is also used to encompass a variety of other changes such as an increased role for large corporations (MNCs) in the world economy and increased intervention into domestic policies and affairs by international institutions such as the IMF, WTO, and World Bank (Source: University of Michigan, Ann Arbor Alan Deardorff, Gerald Ford School of Public Policy, International Economics, 2016).

GREEN ECONOMY refers to new sectors of the economy that produces less greenhouse gases and can create jobs for working class communities and communities of color (Loh & Eng, 2010).

GREEN ZONES are areas overburdened by pollution and blight that have been transformed into cleaner, more attractive spaces through local and community-based policies that reduce

GLOSSARY continued

environmental hazards, and promote less-polluting economic development (Cuajunco & Vanderwarker, 2015).

FREE-FLOW SYSTEMS are systems of terminal off-loading in which terminal operators unload containers and group them together so that truckers can theoretically pick up any container.

HEAVY-DUTY DRAYAGE TRUCKS are any on-road vehicle with a gross vehicle weight rating (GVWR) greater than 33,000 pounds operating on or transgressing through ports or intermodal rail yard properties for the purpose of loading, unloading or transporting cargo, such as containerized, bulk or break-bulk goods (Air Resources Board, n.d.).

HIGH-OCCUPANCY TOLL (HOT) lanes are passenger travel lanes on highways that are restricted by tolls.

HIGH-OCCUPANCY VEHICLE (HOV) lanes are passenger travel lanes on highways that are restricted by number of passengers, more commonly referred to as carpool lanes.

INDEPENDENT OWNER OPERATOR (IOO) is a worker classification for truck drivers who operate as independent contractors. IOOs are not considered employees of trucking companies, and therefore are not subject to the same workers compensation protections, benefits, minimum wage, or workweek standards. IOOs are truckers are also

usually compelled to pay for their own truck, fuel, tolls, and insurance (Monaco & Grobar, 2005).

INLAND EMPIRE A region containing Riverside and San Bernardino Counties (both of which lay east of LA County).

INLAND PORT An area with a high concentration of warehouses, distribution centers, intermodal facilities, and transportation infrastructure (i.e. rail, highways, and potential future dedicated right-of-ways) this term applies to the parts of Los Angeles, San Bernardino, and Riverside counties with high concentrations of such facilities and infrastructure.

JUST-IN-TIME (JIT) Manufacturing A production model in which items are created and rushed to meet demand, not created in surplus or in advance of need. This model relies on extremely low inventories in retail destinations.

LOGISTICS The management of the supply chain, including the physical and technological infrastructure upon which the global market operates. Public investments and technological advancements over time have helped contribute to falling logistics costs in the US.

NEOLIBERAL POLICY A financial, social, and political theory that asserts the primacy of the market and the idea that social good will be maximized by maximizing the reach and frequency of market transactions (Harvey, 2005).

PIERPASS is system in place at the Ports that levies a fee on each container entering or leaving participating terminals during peak hours (8:00 AM to 5:00 PM). The revenue collecting from the fees allows participating terminals to extend their hours of gate operations to off-peak hours (6:00 PM to 3:00 AM). The program, instituted in 2005, successfully redistributed roughly 50 percent of truck traffic to off-peak periods.

POINT OF SALE TECHNOLOGY A process where once a consumer buys a product/service, that information is relayed back to the supplier. The supplier utilizes that information to inform inventories, company product orders, and much more. The process is meant to reduce costs and streamline the company's participation in the supply chain (Narea, 2015).

SOCIAL EQUITY A term describing access for all to opportunity, livelihood, education, health, and resources; full community participation in public decision-making; self-determination in meeting fundamental needs; and promotion of social justice through public sector and civil society expansion and realignment (Reliable Prosperity, n.d.).

SUSTAINABLE FREIGHT ACTION PLAN A plan, currently in draft form, to take a statewide approach to improving freight efficiency, decrease freight related emissions, and increase the competitiveness of freight in California. The plan is a result of Governor Brown's July 2015 Executive Order.

GLOSSARY *continued*

SUSTAINABILITY implies that the natural environment, human society, and global economic activity must exist in balance. In this balance, quality of human life, environmental regeneration, and environmental justice take precedence over profits for individuals and corporations. As climate change forces humans to adapt, sustainability demands a just transition away from fossil fuels, in which affected workers, unions, and communities envision and create a new energy economy.

THE GOODS MOVEMENT SYSTEM A catchall term to refer to anything related to the storage or movement of raw, intermediate, or final consumer and wholesale products. Generally, this refers to all aspects of the supply chain: ocean vessels, sea ports, rail, trucks, warehouses, and distribution centers.

TRADE LIBERALIZATION An economic phenomenon that favors a move towards freer trade through the reduction of tariff and other barriers. Trade liberalization is generally perceived as the major driving force behind globalization. Rapidly increasing flows of goods and services across national borders have been the most visible aspect of the increasing integration of the global economy in recent decades (United Nations Department of Economic and Social Affairs, 2005).

TRAFFIC DENSITY Sum of traffic volumes adjusted by road segment length (vehicle-kilometers per hour) divided by total road length (kilometers) within 150 meters of the census tract boundary ("CalEnviroScreen Version 2.0," 2014).

TRUCK-ONLY TOLL (TOT) lanes are travel lanes dedicated to trucks (defined by vehicle type) and restricted by tolls (usually levied per-mile). There are no current examples of truck-only toll lanes, although several feasibility studies have analyzed their potential both in the United State and abroad (Cambridge Systematics Inc. & CH2M HILL., 2009)

WORLD CAPITAL MARKETS The market in which buyers and sellers, including institutions, banks, governments, corporations, and individuals, trade debt and equity securities. World capital markets are how investors in a country interact with foreign economies through investment funds and stock markets. (Bank of America Merrill Lynch, 2016).

ZERO-EMISSION AND NEAR-ZERO EMISSION (ZE/NZE) refers to a range of technologies and vehicle types that either greatly reduce greenhouse gas emissions compared to petroleum-fueled engines or completely eliminates emissions.

COMMUNITY SCHOLARS STUDENTS ANALYZE POWER DYNAMICS OF GOODS MOVEMENT PLAYERS IN SOUTHERN CALIFORNIA



Source: Goetz Wolff

ACRONYMS

ACS American Community Survey	LAANE Los Angeles Alliance for a New Economy
ASC Automated Stacking Crane	LED Light-emitting diode
BCO Beneficial Cargo Owner (Retailers)	LNG Liquefied Natural Gas
CalEPA California Environmental Protection Agency	MTO Marine Terminal Operators
Cal/OSHA California Occupational Safety and Health	NAICS North American Industrial Classification System
CARB California Air Resources Board	NHTA National Highway Traffic Administration
CBAs Community Benefit Agreements	NOx Nitrous Oxide
CBE Communities for a Better Environment	OJT On-the Job Training
CFCP Clean Freight Corridor Plan	PPP (or P3) Public-Private Partnership
CNG Clean Natural Gas	PM Particulate Matter
CTP Clean Truck Program	POLA Port of Los Angeles
DPM Diesel Particulate Matter	POLB Port of Long Beach
DTNA Daimler Trucks North America	RMG Rail Mounted Gantry Crane
E-COMMERCE Electronic Commerce (Online consumer spending)	RNG Renewable Natural Gas
ECI European Citizens' Initiative	RTP/SCS Regional Transportation/Sustainable Communities Strategy
EYCEJ East Yard Communities for Environmental Justice	SCAG Southern California Association of Governments
GATT General Agreement on Tariffs and Trade	SCAQMD Southern California Air Quality Management District
GGRF Greenhouse Gas Reduction Fund	SEED STEM, Energy, and Economic Development
GHG Greenhouse Gas	SOx Sulfur Oxide
HOV High Occupancy Vehicle lanes	STEM Science, Technology, Engineering, or Math
HOT High Occupancy Toll lanes	SVA Shared Vessel Agreement
IOO Independent Owner Operator	TCCP Transformative Climate Communities Program
GoMOB Goods Movement Oversight Board	TEU Twenty Foot Equivalent Unit
IPUMS Integrated Public Use Microdata Series	TOT Truck Only Toll lanes
ILWU International Longshore and Warehouse Union	WIOA Workforce Innovation and Opportunity Act
IT Information Technology	WTO World Trade Organization
JPA Joint Powers Authority	ZE/NZE Zero-Emissions and Near-Zero Emission

BIOGRAPHIES

2016 COMMUNITY SCHOLARS

CARLOS SANTAMARIA was a second generation port truck driver before becoming a union organizer with the International Brotherhood of Teamsters. He is involved with the campaign for justice for misclassified port truck drivers at the Ports of Los Angeles and Long Beach. He believes that deregulation created dangerous working conditions and that unionization will allow drivers to turn the tides.

EVELIN CRUZ is a former Walmart employee, New World Foundation OUR Walmart Fund Advisory Board Member, and OUR Walmart Los Angeles Organizer. She has built the largest base of Walmart workers and led the largest strike at her store in Pico Rivera, CA. Evelin is an expert in understanding Walmart's policies and provides support to leaders and members across the country facing violations of Walmart policies in their work sites. Evelin is leading the development of OUR Walmart Hispano which provides a Spanish language space for OUR Walmart workers to share experiences, campaign for policies that impact Latino workers, and receive support on how to handle workplace challenges. Walmart illegally fired Evelin in 2015 for speaking out for change.

JESSICA DURRUM is a Senior Research and Policy Analyst with the Los Angeles Alliance for a New Economy (LAANE), where she has worked on its Clean and Safe Ports Project since 2012. Prior to joining LAANE, she received her Masters in Urban and Regional Planning from UCLA with a concentration in Community Economic Development. Her studies and work have both been grounded in supporting organizing for social and economic justice. She holds a Bachelors of Arts from Wellesley College in History and Spanish.

JOVANI GOMEZ is a former Walmart employee. He joined OUR Walmart in 2012 and became a critical leader of OUR Walmart Los Angeles. Jovani organized Walmart workers in his store and surrounding areas and led direct actions including sit down strikes. Jovani was fired in 2013 and went through the AFL-CIO Organizing Institute where he learned fundamental organizing skills. He has been working as an organizer for over two years.

SYLVIA ARREDONDO is the Development Associate at Communities for a Better Environment (CBE), where she provides grassroots fundraising leadership so that communities of color and low-income communities most impacted by toxins and pollution across California can achieve environmental health and justice, clean energy and healthy communities. She holds a Bachelors of Arts in Political Science and a Minor in Gender & Women's Studies from CSU, San Francisco State.

ZULLY JUAREZ is the Development and Communication staff at East Yard Communities for Environmental Justice. Her work is geared towards creating a safe and healthy environment for communities disproportionately affected by industrial pollution. She received her undergraduate degree in Gender & Women's Studies and Ethnic Studies from the University of California, Berkeley. As a daughter of Guatemalan immigrants, raised in South Central Los Angeles, she is invested in creating storytelling projects for young Maya people in Los Angeles.

BIOGRAPHIES continued

2016 CANDIDATES FOR MASTER OF URBAN & REGIONAL PLANNING, UCLA

ADRIANA QUIQUIVIX is focusing on Housing and Design & Development, particularly how those two processes work for low-income populations. She earned a Bachelor of Arts in Geography as well as a certificate in Geographic Information Systems (GIS) and Urban Studies from Cal State Long Beach. Her academic interests range from participatory planning to housing policies in immigrant communities.

ARIANA VITO is studying Transportation Policy and Planning, with a focus on active transportation, public transit, and environmental sustainability. She is interested in how improved mobility options and technologies can reduce greenhouse gas emissions and create more sustainable communities. She received her bachelor's degree from Northeastern University in Environmental Studies and International Affairs and currently interns for the City of Santa Monica Office of Sustainability & the Environment.

DIANA BENITEZ is studying Community Economic Development and Housing and the intersection of the built environment and health with a particular interest on the impacts on immigrant communities. As a first generation

Salvadoran-American from Pico-Union, Los Angeles, Diana hopes to make changes in existing policies to support healthy, safe, and affordable communities throughout the region. She received her undergraduate degree in Urban Studies and Planning at California State University Northridge.

DYLAN SITTIG is concentrating in Community Economic Development and Environmental Analysis and Policy. He is interested in Los Angeles studies, participatory planning, and environmental justice. Dylan received his undergraduate degree in Urban and Environmental Policy from Occidental College. Dylan enjoys short walks on the beach and beer.

EDBER MACEDO is studying environmental justice, land use policy, and community development. His background is in community organizing, immigrant rights advocacy, and urban policy research. The product of Mexican immigrant parents, he is interested in how large-scale transportation projects and urban housing markets affect marginalized populations. In his spare time, he likes visiting museums, going to the beach, and shopping at Bristol Farms.

EVAN MOORMAN is focusing on Transportation Policy and Planning but he also enjoys learning about housing and economic development issues. He earned a Bachelor of Arts degree in Geography from Macalester College in Saint Paul, MN. He loves eating, drinking coffee, traveling, and taking walks with his fiancé.

GABRIEL GUTIERREZ is concentrating in Community Economic Development and Housing. He is interested in policy and direct service efforts that support marginalized populations as they seek stable housing, financial independence, and self-sufficiency. Gabriel hopes to combine his background in social services with an urban planning and public policy lens to help fill gaps in services for those most in need in Los Angeles. His passion for social justice was influenced by his diverse upbringing and exposure to indigenous cultures of North and South America. He is currently the Development Coordinator for The Right Way Foundation, a non-profit organization that provides job readiness training, mental health services, and job placement services to current and former foster youth in Los Angeles County.

BIOGRAPHIES continued

2016 CANDIDATES FOR MASTER OF URBAN & REGIONAL PLANNING, UCLA

KATE BRIDGES is studying Transportation Policy and Planning. She loves the idea of a balanced, multimodal transportation system in Los Angeles. Her interests include travel behavior, public participation, and the relationship between mobility and economic opportunity. Kate received her undergraduate degree in Human Evolution & Cognition from Pomona College. In her free time, she enjoys hiking with her dog, backyard barbecuing, and reading novels.

LINDSEY JAGOE is concentrating in Design & Development with a focus in affordable housing policy and development. Currently, she is working for a development consultant firm that specializes in permit expediting and planning entitlements. She holds a bachelor's degree in Philosophy from Transylvania University in Lexington, Kentucky. In her free time, you can find Lindsey practicing yoga or hanging out with her two cats.

MEGHMIK BABAKHANIAN is studying Transportation Policy & Planning, Design & Development, and how the intersection of the two affects the economy. She received her undergraduate degree in Economics from the University of California, Berkeley and is interested in helping public agencies fund

their infrastructure projects using municipal bonds. She remains an advocate for the Armenian cause as well as raising awareness of congenital disorders of glycosylation (CDG).

MICHAEL BARRITA-DIAZ is focusing on community economic development and housing with an emphasis on inclusive neighborhood revitalization. Michael works for Councilmember Gilbert Cedillo in council district 1, concentrating on gentrification, commercial revitalization and retention, and policy development. He holds a bachelor's degree from the University of California, Los Angeles in Political Science and Chicana/o Studies.

SALY HENG is concentrating in Transportation Policy and Planning. He has a background in transportation engineering and seeks to understand the push and pull of land-use and transportation in Los Angeles County. As a first generation Cambodian-American raised in Paramount, CA, Saly hopes to ensure there is visibility between participatory planning and the infrastructure that bridges different communities together.

SAM APPEL is an urban planning student with a love and respect for organizing. He studies participatory planning, popular education, and the urban politics of housing, economic development, and incarceration, and organizes around racial justice among white people, fossil fuel divestment, and gentrification. He eagerly awaits riding his bike again throughout California when he graduates.

STEPHANIE TSAI is concentrating in Community Economic Development with an emphasis on labor and workforce development. She is interested in just, equitable, and inclusive economic development, worker organizing, and participatory processes as well as the collateral consequences and implications of incarceration, particularly for communities. She spent several years working on state and local policy and politics in the San Francisco Bay Area after attending the University of California, Berkeley for her undergraduate degree.

